



Quantum T AdB Dispensers



Installation Manual



Document Ref 908397-001
Rev - 8
07/2009

Great care has been taken in the preparation of this manual however Tokheim shall not be liable for any misunderstanding, errors and/or loss or defect arising from the use of this manual.

Tokheim shall not be liable for damage to the product, nor for personal or third party injury, caused by incorrect use of the product or by attempts to maintain or to repair the product by parties other than those fully trained by Tokheim or by its accredited third party representatives.

Please contact your nearest service department, at the relevant address printed on the back cover of this manual, should any aspect of this manual be unclear.

© Copyright by Tokheim. All intellectual rights arising from, accruing to, and residing in this manual belong to Tokheim. No part of this document may be reproduced in any form without the express written permission of Tokheim.

Tokheim reserves the right to apply changes to this document and the equipment without further notice.

Dear Customer

Tokheim has produced the best dispenser for this new product based on Urea at 32.5% concentration, designated as AdBlue® in this manual (naming dependent upon country, customer and brand name).

As per today's standards and available data, this dispenser will not contaminate your AdBlue® liquid. Sampling over minimal deliveries of liquid from the dispenser complies with the DIN 70070 Standard. Tests performed on new dispensers have shown that the dispenser's contribution towards contamination is within the requirements of the Standard. Tokheim Engineering is still investigating the behaviour of dispensers over time to anticipate the need for preventive maintenance.

As a consequence, this manual is only provisional. Prescription for preventive maintenance is not included in this manual and Tokheim's recommendations for preventive maintenance will be incorporated into the Tokheim AdBlue® Manuals as soon as practicable, and include the following (without limitation):-

- *Preventive sampling action and check (as per applicable standards)*
- *Preventive part replacement*
- *Preventive visual inspection*

Important - any maintenance action must only use genuine Tokheim AdBlue® spare parts.

AdBlue® installations must comply with local rules and regulations, for example, W&M, ATEX, environmental policies etc. (this list may differ from one country to another).

Installation must also be such that it does not contaminate the AdBlue® liquid. AdBlue® is corrosive and all pipework, tanks, vents, pumps, inlets and associated equipment in normal or accidental contact with AdBlue® must be AdBlue® compatible. For example (list incomplete):-

- *Calibration containers (Warning: risk of contaminating AdBlue® with diesel or unleaded)*
- *Sewage water/oil separation for surface rain water*
- *Delivery trucks*
- *Transfer storage*

Safety rules applicable to AdBlue® as described in this manual are not limiting nor invalidating of the recommendations of AdBlue® producers as per their safety data sheet. AdBlue® safety data sheets should be available in every service station.

This page is intentionally blank

REVISION RECORD

Date	Revision	Page	Reason
02/06/2005	1	All	Original Issue
02/02/2006	2	front pages	Added legal note
02/02/2006	2	3,4	Main Contents revised
02/02/2006	2	1-2,1-3	Info added on Heating System
02/02/2006	2	1-10	Typeplate drawing revised
02/02/2006	2	2-5 to 2-7	Schematic names changed
02/02/2006	2	3-6 to 3-8	Drawings updated
02/02/2006	2	4-4	Info added to keep filler cap ring inside hydraulic door
02/02/2006	2	5-1	Section 5 Contents revised
02/02/2006	2	5-4,5-5	Drawings updated; Warning note added
02/02/2006	2	5-10,5-11	Drawings updated
02/02/2006	2	5-15	Info added to keep filler cap ring inside hydraulic door; warning note added; note added to cover new fill box and position
02/02/2006	2	5-19 to 5-26	Updated wiring drawings added; repagination
02/02/2006	2	6-2	Info added on ring magnet
02/02/2006	2	back cover	Addresses revised
11/01/2007	3	front pages	Legal information revised
11/01/2007	3	3,4	Main Contents revised
11/01/2007	3	1-2,1-3	References to Combined diesel models removed; new info added for CP models; repagination
11/01/2007	3	1-4 to 1-9	Combined diesel models info removed; changed ref to "fuel" to "AdBlue"; repagination
11/01/2007	3	1-10	Combined diesel models info removed; repagination
11/01/2007	3	2-1	Section 2 Contents revised
11/01/2007	3	2-4	Combined diesel models removed; CP models added
11/01/2007	3	2-5 to 2-7	Combined diesel models removed; CP models added; new sub connections added
11/01/2007	3	2-8	New sub connections added
11/01/2007	3	2-9 to 2-12	Pages deleted
11/01/2007	3	3-1 to 3-6	Combined diesel models removed; CP models added; container model & ground plan updated
11/01/2007	3	3-7 to 3-10	Pages deleted
11/01/2007	3	4-1	Section 4 Contents revised
11/01/2007	3	4-3	Photos and text updated
11/01/2007	3	4-4	Combined diesel models info removed
11/01/2007	3	4-5,4-6	Combined diesel models removed; new info added for CP models
11/01/2007	3	5-1	Section 5 Contents revised
11/01/2007	3	5-2,5-3	References to Combined diesel models removed; new info added for CP models; repagination
11/01/2007	3	5-4,5-5	References to Combined diesel models removed; new info added for CP models; repagination
11/01/2007	3	5-6 to 5-9	Combined diesel models removed; pictures and info updated; new info added for CP models; repagination
11/01/2007	3	5-10,5-11	Combined diesel models removed; pictures and info updated; new info added for CP models; repagination
11/01/2007	3	5-12 to 5-14	Combined diesel models removed; pictures and info updated; new info added for CP models; repagination
11/01/2007	3	5-15	New info added; repagination
11/01/2007	3	5-16 to 5-18	New info added for CP models; repagination

Date	Revision	Page	Reason
11/01/2007	3	5-19 to 5-26	Combined diesel models removed; new info added for CP models & sliding door/low temp alarm; repagination
11/01/2007	3	5-27,5-28	Repagination
11/01/2007	3	6-1	Section 6 Contents updated
20/09/2007	3	6-3 to 6-5	New info added on disposal of AdB; container thermostat temperature setting changed; repagination
20/09/2007	4	3,4	Main Contents revised
20/09/2007	4	1-10	Typeplate drawing updated
20/09/2007	4	5-1	Section 5 Contents revised
20/09/2007	4	5-6,5-8,5-9	New info added for fixing to ground
20/09/2007	4	5-10,5-11	Repagination
20/09/2007	4	5-12,5-13	Repagination
20/09/2007	4	5-14,5-16	New info inserted (ATEX heating systems); repagination
20/09/2007	4	5-15	New info inserted (ATEX heating systems); repagination
20/09/2007	4	5-17,5-18	Repagination
20/09/2007	4	5-19 to 5-21	Repagination
20/09/2007	4	5-22,5-23	New info inserted (ATEX heating systems); repagination
20/09/2007	4	5-24 to 5-26	Repagination
20/09/2007	4	5-27,5-28	Repagination
20/09/2007	4	5-29 to 5-40	New info added (ATEX heating systems); new pages inserted; repagination
10/01/2008	5	3,4	Main Contents revised
10/01/2008	5	1-1	Section 1 Contents revised
10/01/2008	5	1-8	New info added for MID
10/01/2008	5	2-3	Zoning diagram updated
10/01/2008	5	5-1	Section 5 Contents revised
10/01/2008	5	5-10,5-11, 5-15	New info added for earthing; repagination
10/01/2008	5	5-12 to 5-14, 5-16 to 5-18	Repagination
10/01/2008	5	5-19 to 5-26	Repagination
10/01/2008	5	5-27,5-28	Repagination
10/01/2008	5	5-29 to 5-40	Repagination
10/01/2008	5	6-1	Section 6 Contents revised
10/01/2008	5	6-4,6-5	New info added for MID; repagination
23/12/2008	6	5-21	AdB Standalone electrical drawing updated to show sub pump power entering j/box from top
23/12/2008	6	5-12	Removal of foam transportation blocks
30/05/2009	7	1-9	New Atex Certificate
30/05/2009	7	2-6, 2-7	New drawings of riser pipe
30/05/2009	7	5-10	Addition of text for low voltage directive (safety earth)
30/05/2009	7	5-11	New Adblue pipework photos
30/05/2009	7	5-18	Addition of text for low voltage directive (Mains fuses)
31/07/2009	8	2-4	Mini Combo Zoning Diagram
31/07/2009	8	2-8, 2-9	Mini Combo Zoning Schematics
31/07/2009	8	3-4	Mini Combo Model Adb MCP with VHS
31/07/2009	8	3-7	Model Adb 1-1/1-2 MCP with VHS 1-1/1-2
31/07/2009	8	3-8	Model Adb 1-2 MCP with VHS 2-4
31/07/2009	8	3-9	Model Adb 1-2 MCP with VHS 3-6
31/07/2009	8	4-3	Mini Combo Weights
	9	5.7.3	Atex water heating overview. Addition of anti freeze instructions
	9	5.13	Current ratings for AdBlue dispensers
	9	6.2	Important Information Prior to commissioning

CONTENTS

1 INTRODUCTION..... 1-2

1.1 How To Use This Manual 1-2

1.2 Product Scope 1-3

1.3 Authorised Technicians 1-3

1.4 Contact Information 1-3

1.5 Health & Safety 1-3

1.5.1 Safety Checklist 1-3

1.5.2 Duties of the Employees 1-4

1.5.3 Hazards 1-4

1.5.4 Warning Signs 1-5

1.5.5 Personal Protective Equipment (PPE) 1-6

1.5.6 AdBlue ® Contact - First Aid Procedures 1-7

1.5.7 Storage of AdBlue ® 1-8

1.5.8 Spillage of AdBlue ® 1-8

1.6 Standards & Certificates 1-9

1.6.1 Dispenser Marking for the ATEX Directive (ATEX Models only) 1-9

1.7 MID Dispensers 1-10

2 SITE PREPARATION 2-2

2.1 General 2-2

2.1.1 Island Preparation 2-2

2.1.2 Zoning Diagram 2-2

2.1.3 Mini Combo Zoning Diagram 2-4

2.2 Basic Model Schematics 2-5

2.2.1 Standalone AdB Models 2-5

2.2.2 AdB with Container Models 2-6

2.3 Mini Combo Schematics 2-7

2.3.1 Standalone Mini Combo Models 2-7

2.4 Hydraulic Connections - AdBlue ® only 2-9

2.4.1 Recommended Riser Height for AdBlue ® 2-9

2.4.2 Submerged Connection for AdBlue ® - G1.5” SST 2-10

2.5 Electrical Connections 2-11

3 DRAWINGS 3-2

3.1 Dispenser Dimensions 3-2

3.1.1 Standalone AdBlue ® only - Models AdB 1-1, 1-1cp, 1-2, 1-2cp 3-2

3.1.2 AdBlue ® & Container - Models AdB 1-1t & 1-2t 3-3

3.1.3 Mini Combo - Model AdB MCP with VHS 3-4

3.2 Ground Plans 3-5

3.2.1 Standalone AdBlue ® only - Models AdB 1-1, 1-1cp, 1-2, 1-2cp 3-5

3.2.2 AdBlue ® & Container - Models AdB 1-1t & 1-2t 3-6

3.2.3 AdBlue ® - Model AdB 1-1/1-2 MCP With VHS 1-1/1-2 3-7

3.2.4 AdBlue ® - Model AdB 1-2 MCP With VHS 2-4 3-8

3.2.5 AdBlue ® - Model AdB 1-2 MCP With VHS 3-6 3-9

4 PACKAGING & HANDLING 4-2

4.1 Shipping Documentation 4-2

4.2 Packaging 4-2

4.2.1 Unpacking 4-2

(CONT.)

4	PACKAGING & HANDLING/	
4.3	Inventory Inspection	4-3
4.4	Weights	4-3
4.5	Handling	4-3
4.6	Access the Hydraulic Area	4-4
4.7	Access the Calculator Head	4-4
4.8	Access the DIT Spacebox/Glands	4-5
4.9	Accessing the Crypto VGA	4-6
4.10	Access the Container	4-6
4.11	CP Models - accessing the host dispenser	4-6
5	INSTALLATION	5-2
5.1	General	5-2
5.2	Identification of Side A	5-2
5.2.1	Standalone AdB only dispensers	5-2
5.2.2	CP Models	5-3
5.2.3	Container & AdB dispensers	5-3
5.3	Lifting	5-4
5.4	Placement	5-4
5.4.1	Standalone AdB only - By Forklift	5-5
5.4.2	CP Models - By Forklift	5-7
5.4.3	Container & AdB Dispensers - By Forklift	5-7
5.4.4	Fixing to Ground	5-9
5.4.5	Earthing	5-10
5.5	Hydraulic Connections	5-11
5.5.1	AdBlue ® Pipework	5-11
5.6	Filling the AdBlue ® Container	5-12
5.6.1	Instructions for Tokheim AdBlue ® Containers	5-12
5.6.2	Instructions for Customer Specific 1 AdBlue ® Containers	5-13
5.6.3	Leak Detection systems	5-14
5.7	Heating Systems	5-15
5.7.1	Non-ATEX Heating Overview	5-15
5.7.2	ATEX Electric Heating Overview	5-16
5.7.3	ATEX Water Heating Overview	5-17
5.7.4	Filling and Priming the Water Heating System	5-18
5.8	Electrical Connections - General	5-19
5.8.1	Main M2000 Junction Box Wiring	5-19
5.9	AdB Standalone & AdB Container Dispensers	5-21
5.9.1	Position of Junction Boxes in AdB dispensers	5-21
5.9.2	No Heating & Non-ATEX Heating	5-22
5.9.3	ATEX Electric Heating	5-24
5.9.4	ATEX Water Heating	5-25
5.10	AdB dispensers	5-26
5.10.1	Position of Junction Boxes in AdB CP & Host dispensers	5-27
5.10.2	No Heating & Non-ATEX Heating	5-28
5.10.3	ATEX Electric Heating	5-34
5.10.4	ATEX Water Heating	5-36
5.11	Electrical Options	5-38
5.11.1	Fire and/or Shock Detection	5-38
5.11.2	Audio/Speaker	5-38
5.11.3	Sliding Door and/or Low Temperature Alarm	5-39

(CONT.)

5	INSTALLATION/	
	5.11.4	Special Dispenser Configurations 5-39
	5.12	Communications Wiring in Main Junction Box 5-40
	5.13	Current ratings for AdBlue dispensers 5-43
6	COMMISSIONING	6-2
6.1	Test and Programming the Dispenser	6-2
	6.1.1	Program the Dispenser 6-2
	6.1.2	Dispenser Functions 6-2
	6.1.3	Test the Dispenser 6-2
6.2	Calibration of the Dispenser	6-4
	MID Certified Dispensers	6-4
	6.2.1	Calibrate the Meter 6-4
	6.2.2	Disposal of AdBlue ® Calibration Test Fuel 6-4
6.3	Final Checks	6-5
6.4	Handing over to the Station Manager	6-5

GLOSSARY OF TERMS USED IN THIS MANUAL

This page is intentionally blank

CONTENTS

1 INTRODUCTION..... 1-2

- 1.1 How To Use This Manual 1-2
- 1.2 Product Scope 1-3
- 1.3 Authorised Technicians 1-3
- 1.4 Contact Information 1-3
- 1.5 Health & Safety 1-3
 - 1.5.1 Safety Checklist 1-3
 - 1.5.2 Duties of the Employees 1-4
 - 1.5.3 Hazards 1-4
 - 1.5.4 Warning Signs 1-5
 - 1.5.5 Personal Protective Equipment (PPE) 1-6
 - 1.5.6 AdBlue ® Contact - First Aid Procedures 1-7
 - 1.5.7 Storage of AdBlue ® 1-8
 - 1.5.8 Spillage of AdBlue ® 1-8
- 1.6 Standards & Certificates 1-9
 - 1.6.1 Dispenser Marking for the ATEX Directive (ATEX Models only) 1-9
- 1.7 MID Dispensers 1-10

1 INTRODUCTION

IMPORTANT INFORMATION - AdB HEATING SYSTEM

Advise the Station Manager that AdBlue ® liquid consisting of 32.5% Urea in water solution will freeze at -11°C. Tokheim's integrated heating system is designed to prevent the product from freezing and causing damage to the dispenser at temperatures down to -25°C. Any interference to the heating system may cause a malfunction, invalidate the warranty and Tokheim will not be liable. AdBlue ® dispensers supplied without the heating system connected should not be exposed to freezing conditions as per above.

1.1 How To Use This Manual

It is recommended that all relevant persons familiarise themselves with the contents of this manual prior to carrying out any operations or procedures.

This manual is divided into sections which are described as follows: -

Section 1 - Introduction

This section contains information on how to use the manual, the scope of equipment covered, recommendations on qualified technicians and contact information. It also includes relevant health and safety information required for the safe installation and commissioning of the product.

Section 2 - Site Preparation

This section details the procedures to be carried out in preparation for receipt of equipment at site and the necessary actions prior to installation.

Section 3 - Drawings

All necessary drawings required for reference during the installation and commissioning, are listed and contained in this section.

Section 4 - Packaging and Handling

This section provides instructions for unpacking and safe handling of the equipment.

Section 5 - Installation

The instructions for the correct installation of the equipment are contained within this section including filling the AdBlue ® & Container unit and connecting an AdBlue ® CP dispenser to an existing Tokheim host dispenser.

NOTE : THE INSTALLATION, MAINTENANCE AND PARTS MANUALS FOR THE EXISTING (HOST) DISPENSER MUST BE AVAILABLE FOR CROSS REFERENCE.

Section 6 - Commissioning

This section highlights the actions and checks, to be carried out, in preparation for the commissioning activity and the procedures required from commissioning of the equipment to handover.

1.2 Product Scope

The equipment and models covered by the contents of this manual are:-

The Quantum T AdB range of fuel dispensers, including Standalone AdB only, AdB Combo Prepared (CP) and AdB Container models. For information on CP dispensers, refer also to the relevant QT dispenser manuals as provided by Tokheim.

All dispensers in the QT AdB range use the same standard sub-assemblies and offer a wide range of configurations and includes provision for options such as integrated payment terminal, audio, fire and shock detection etc.

1.3 Authorised Technicians

Only qualified technicians familiar with the contents of this manual should carry out the procedures contained herein.



WARNING: ANY ATTEMPTS TO CARRY OUT THE PROCEDURES OF THIS MANUAL, BY UNQUALIFIED OR UNAUTHORISED PERSONS, MAY RESULT IN SERIOUS INJURY OR LOSS OF LIFE.

NOTE: - THIS MANUAL IS NOT INTENDED TO REPLACE THE SERVICES OF A FULLY QUALIFIED TECHNICIAN.

1.4 Contact Information

For information relating to the contents of this manual please contact: -

Technical Author
Tokheim UK Ltd.
Dundee, Scotland

For technical assistance please contact the appropriate service division listed on the back cover of this manual.

1.5 Health & Safety

1.5.1 SAFETY CHECKLIST

- Any smell of ammonia must be reported immediately.
- It is obligatory that this checklist be fully complied with during all work at the filling station, particularly construction or repair work.
- It is the duty of the contractor to ensure that all workers employed by him obey each and all of the relevant laws, directives and other regulations.
- AdBlue ® liquid must only be stored in AdBlue ® compatible containers/storage tanks.

Areas where special caution is required

- The insides of tanks, tubes, dome shafts, filling shafts, change over shafts, vessels and dispensers.
- All areas in which fuel vapour that is heavier than air can accumulate, e.g. fuel separator, draining shafts, low located rooms, cellars, excavations, pipe trenches etc.

- The areas around the outlets of tank ventilation pipes, especially during the filling phase.
- All areas near dispensers, tanker lorries and other vehicles while they are being tanked up, and particularly when there is a lack of wind.
- A radius of 1.0 metres around petrol carrying pipes, as well as pipes that are not vapour free.
- Silt traps.

1.5.2 DUTIES OF THE EMPLOYEES

- To ensure optimal accident prevention in our company, in addition to general rules applying to worker's protection, it is necessary to take into account all the national protection of workers legislation and to actively support all measures which enhance safety standards.
- It is an employee's duty to follow all company directives regarding the prevention of accidents, unless such directives can be proved to be unfounded.
- Employees should not follow any instructions that go against safety standards.
- Employees are only permitted to use equipment for its original purpose, and this is defined by the company alone.
- If an employee detects equipment that is deficient in terms of safety, he shall eliminate this deficiency immediately. If such safety rectification is not part of his defined area of activities, or if his knowledge is insufficient to carry out such work he must immediately inform his superior about the detected safety deficiency.

This equally applies to:

- 1) **Work Materials** which have not been correctly packed or correctly marked in order to meet safety requirements.
- 2) **Work Methods** or work processes which have not been correctly coordinated or controlled in order to meet safety requirements.
- 3) **Where dangerous activities are carried out by several persons**, the need for a permanent faultless communication between them in order to avoid dangerous events shall require the appointing of one person in order to carry out overall supervision.

1.5.3 HAZARDS

Prior to starting work, the dispenser must be isolated (i.e. entirely disconnected from the mains supply) and the mains supply switch locked in the OFF position. The submerged pump (if applicable) and control signals from the dispenser must also be isolated. This is done to provide safety for the technician. As a further precaution, switch off the mains supply in the service station shop and place a clear notice on the switch to avoid it being turned on again inadvertently.







WARNING:- THE CONNECTION AND DISCONNECTION OF ELECTRICAL CONNECTIONS MAY ONLY BE CARRIED OUT BY QUALIFIED PERSONNEL AUTHORISED FOR SUCH ACTIVITIES. WORK IN DANGEROUS AREAS MUST BE MADE SAFE BY OBSERVING ALL THE NATIONAL SAFETY REQUIREMENTS IN FORCE.

It is not permitted to put an AdBlue® dispenser into operation before an authorised official has inspected it and released it. This depends upon the national regulations in force. Dismantled packaging and cladding must be stored in such a way as to avoid damage to components or injuries to persons. Covers that can be opened, such as the calculator housing, should be handled with care. Ensure that the retaining catch is placed in the correct position to prevent the cover falling onto the head of the service engineer or other persons in the area.

At unattended service stations, every end-user should be able to read the User Instructions. They should be visible on a notice board or integrated into the DIT and should be sufficiently well lit so that they can be read at night. At unattended service stations break away couplings must always be used to reduce the danger caused by a motorist driving off with the nozzle still in the tank.

1.5.4 WARNING SIGNS

The following warning signs are fitted as standard, on the dispenser, however they may vary according to individual country requirements or customer specifications.

SIGN	MEANING	POSITION
	Do not use mobile phones	Visible from both sides of dispenser
	Naked flames and smoking forbidden	Visible from both sides of dispenser
	Do not spill liquid on the ground	Visible from both sides of dispenser
	Stop vehicle engine	Visible from both sides of dispenser
	Trucks only	At Diesel high speed dispensers near the nozzle boots

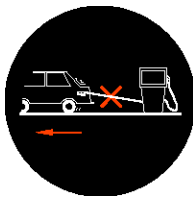

Do not drive away with nozzle in tank

Visible from both sides of dispenser

For more information see User Manual available at this station

Next to User Instructions near the nozzle boot

1.5.5 PERSONAL PROTECTIVE EQUIPMENT (PPE)

PROTECTIVE CLOTHING

The following clothing should be worn **at all times** during installation and maintenance procedures:-

- Protective helmet.
- Protective shoes (conductive).
- Protective gloves and/or protective hand cream.
- Anti static clothing.
- Eye protection.

SAFETY EQUIPMENT FOR WORKING IN HAZARDOUS AREAS

The following safety equipment is required for working in hazardous areas:-

- Only spark free tools are permitted for work on dispensers.
- Work on bearings is only permitted using the standard workshop tools authorised for this kind of work.
- The use of all electrical tools is strictly prohibited.
- Only the use of explosion protected work lights is permitted.
- The use of telecommunications equipment in hazardous areas is strictly prohibited.

SAFETY INSTRUCTIONS

The following safety instructions must be adhered to during installation and maintenance procedures:-

- Inhalation of AdBlue ® vapour must be avoided. Suitable precautions must be taken and where necessary respirators used.
- Avoid direct contact of AdBlue ® with the skin.
- Use suitable protective clothing, protective gloves and/or protective hand cream.
- Avoid fuel spills.
- No smoking, no naked flames are permitted.
- Long hair and ties can get caught in moving parts. Hair must be suitably covered.

1.5.6 AdBlue ® CONTACT - FIRST AID PROCEDURES

Safety Data Sheets for all products should be available in the Service Station. These sheets contain important health and safety information relating to the individual product and the specific precautions to be followed in the event of prolonged contact, inhalation or consumption.

AdBlue ® is normally a clear liquid with little or no odour making leakages difficult to detect. After a period of time the odour may change to a strong ammonia stench. Decomposition on heating may produce toxic fumes of carbon monoxide, carbon dioxide, nitrogen oxide and ammonia reducing the amount of oxygen in the air.

In the event of personal contact with AdBlue ®, the following procedures should be carried out immediately:-

EYE INJURIES

If the eyes have come into contact with AdBlue ®:-

- Pour copious amounts of water over the eyes immediately.
- Rinse eyes thoroughly by keeping eyes open and eyelids away from eyes.
- Continue to rinse the eyes with fresh running water for at least fifteen minutes.
- Removal of contact lenses after an eye injury must be undertaken by trained personnel.
- Seek medical advice if irritation continues.

SKIN CONTACT (BURNS)

If the skin has come into contact with AdBlue ®:-

- Immediately cool affected skin with cold water over the affected area.
- Carefully remove all clothing which has been in contact with AdBlue ®.
- Continue to rinse the affected area with ample water for at least fifteen minutes.
- Apply antiseptic bandages to the affected areas.
- Seek medical advice if irritation continues.

INHALATION (OF AdBlue ® LIQUID/AMMONIA/BIURET)

Do NOT enter the danger zone without adequate protection including respiratory mask and/or aforementioned protective clothing.

If any toxic fumes have been inhaled :-

- If possible, remove the person out of the contaminated area into fresh air.
- Lay the person down and loosen their clothing, keep warm and rested.
- If the person is unconscious, place them in the recovery position.
- If necessary, trained personnel should apply oxygen or artificial respiration to the person.
- Call for medical assistance if breathing difficulties continue.

INGESTION

If AdBlue ® liquid has been ingested:-

- Do NOT induce vomiting.
- If vomiting occurs, lean person forward to maintain open airway and prevent aspiration.
- Rinse out mouth with water before trying to ingest a comfortable amount.
- Seek medical advice if large amounts have been ingested or if irritation continues.

1.5.7 STORAGE OF AdBlue ®

AdBlue ® liquid will crystallise at low temperatures and at elevated temperatures (above 50°C), it can form biuret and ammonia. Always store AdBlue ® liquid away from sources of heat or fire in AdBlue ® compatible containers in segregated, approved and labelled areas.

Store away from incompatible materials and avoid contact with strong oxidizers, acids, alkalies, nitrates, sodium or calcium hypochlorite which can react with AdBlue ® to form a potentially explosive mixture. Do not store for long periods (over six months).

Ensure the container is securely sealed, protected against physical damage and checked regularly for leaks. If a third party tank/container for the supply of AdBlue ® is installed on the service station, refer to the manufacturer's recommendations for filling, emptying, cleaning, handling and storage of the tank/container unit.

1.5.8 SPILLAGE OF AdBlue ®

Although classified as non-hazardous, AdBlue ® liquid, when spilt, will form crystals and creep. If left unattended, this will create a slippery surface. All spillages of AdBlue ® liquid must be reported immediately to the Station Manager. Avoid breathing vapours and contact with skin and eyes by use of PPE.

AdBlue ® SPILLAGE ON FORECOURT:-

- Liberally cover the spillage with sand, earth or other inert, absorbent material.
- For larger spills, contain the spill with sand or earth and prevent spillage from entering drains or surface waterways.

Note : Do not release into surface water and do not empty into drains.

- When dry, transfer into a suitable container for controlled disposal.
- If AdBlue ® is leaked into the drainage system, flush liberally with plenty of water.
- Apply prevailing national/local regulations for waste disposal.

AdBlue ® SPILLAGE ON DISPENSER/VEHICLE:-

- Use a soft cloth and water to remove small spillages on the dispenser/vehicle.



WARNING : RISK OF ELECTRICAL SHOCK - NEVER USE A HOSE OR HIGH PRESSURE SPRAY NEAR THE AdBlue ® DISPENSER

1.6 Standards & Certificates

This dispenser is constructed in conformity with the requirements of all the applicable European Directives (Machinery 98/37/EC; EMC 89/336/EEC).

Tokheim AdB dispensers can be supplied ATEX certified and, as such, may be installed with the hydraulic cabinets in hazardous zone 1 or 2 areas of the service station. Non-ATEX certified Tokheim AdB dispensers must be installed in non-hazardous areas of the service station (i.e. at a specific distance from a petrol dispenser). Refer to section 2.1.2 Zoning Diagrams.

The components used within the ATEX certified dispenser, including connection facilities, are selected in accordance with the European Standard EN BS 60079-0 (Electrical Apparatus for explosive gas atmospheres), and the supplementary Standards listed therein.

The vapours from AdBlue ® dispensers do not create an explosive hazard, but due to the probability of these being in close proximity to gasoline dispensers, the same construction rules are applicable.

The ATEX certified dispenser is certified by SIRA as suitable for use in Potentially Explosive Atmospheres Directive 94/9/EC.

The AdBlue ® meter has been tested by NMI and test report R117/1995-NL 1-05-03 has been issued.

The production and end test is controlled through the Quality Assurance systems within the Tokheim Manufacturing Centres, and has received Quality Assurance Notification from a Notified Body.

No modification to the dispenser may be performed without express permission from Tokheim and must always use original components or Tokheim retrofit kits. Failure to comply with the above will invalidate product conformance with the relevant European Directives and Tokheim will no longer accept product liability.

1.6.1 DISPENSER MARKING FOR THE ATEX DIRECTIVE (ATEX MODELS ONLY)

The ATEX certified dispenser is labelled by Tokheim in accordance with the requirements of the ATEX Directive. This labelling includes:-

- The CE mark (CE conformity)
- The specific explosion protection mark, together with the mark indicating the equipment group and category; and, relating to equipment group II, the letter “G” (concerning explosive atmospheres caused by gases and vapours)
- The “Tokheim” name or logo and manufacturing location
- The dispenser type and serial number including the year of production

Labels can either be plastic stickers or metal plates and may vary according to national requirements.

A typical example of such a label follows:-

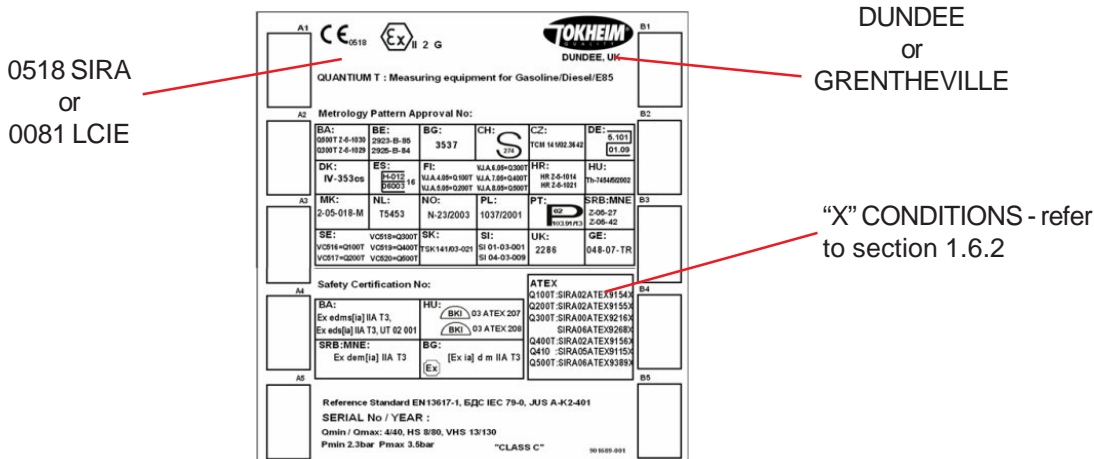

1.7 MID Dispensers

From mid 2007, Tokheim dispensers may be shipped from European factories in accordance with the Metrological Instruments Directive (MID). Such dispensers are calibrated and the relevant seals stamped in the factory so that the dispensers are fit for trade immediately upon installation without the need for a local Weights and Measures inspector to put them into use.

The dispenser is shipped with its own “MID datasheet” which documents the serial numbers of the prime components fitted in the dispenser. This datasheet must remain with the dispenser. Similarly dispensers are shipped with a Declaration of Conformance to the MID. This document must not be lost as it is an essential document to allow the continued use of the dispenser.

MID dispensers can be identified by the typeplate which contains a reference to the MID certificate number as shown:-

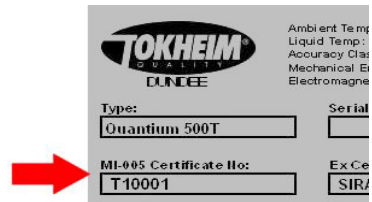

CHECKING THE SEALS



It is the responsibility of the Installer to check that all required seals are present and correct prior to putting the dispenser into use. This includes seals on the pumping unit, meter, pulser and calculator. **Under no circumstances must any seals be disturbed or broken during installation.**

METER CALIBRATION

A calibration check should be performed during Commissioning (refer to section 6).

If a seal is damaged or missing, or if the calibration is outwith legal tolerances or in the unlikely event that any repair is required to a pumping unit, meter, pulser or calculator during installation, the factory MID verification is invalidated and a local National verification will need to be performed before the dispenser can be used.

CONTENTS

2 SITE PREPARATION 2-2

- 2.1 General 2-2
 - 2.1.1 Island Preparation 2-2
 - 2.1.2 Zoning Diagram 2-2
 - 2.1.3 Mini Combo Zoning Diagram 2-4
- 2.2 Basic Model Schematics 2-5
 - 2.2.1 Standalone AdB Models 2-5
 - 2.2.2 AdB with Container Models 2-6
- 2.3 Mini Combo Schematics 2-7
 - 2.3.1 Standalone Mini Combo Models 2-7
- 2.4 Hydraulic Connections - AdBlue® only 2-9
 - 2.4.1 Recommended Riser Height for AdBlue® 2-9
 - 2.4.2 Submerged Connection for AdBlue® - G1.5" SST 2-10
- 2.5 Electrical Connections 2-11

NOTE:-

For CP models, refer also to relevant dispenser Installation, Maintenance and Parts Manuals as appropriate for the hydraulic and electronic connection drawings.

2 SITE PREPARATION

2.1 General

2.1.1 ISLAND PREPARATION

Tokheim AdB dispensers must only be installed on a level island or forecourt surface.

Tokheim AdB dispensers with Container will require a level surface area of approx. 3.6m x 1.3m. The exact ground plan will depend on the model ordered. See drawings in Section 3.

2.1.2 ZONING DIAGRAM

Tokheim AdB dispensers do not create hazardous areas (potentially explosive atmospheres) and therefore there are no zoning diagrams associated with these dispensers.

Tokheim AdB dispensers can be supplied ATEX certified and, as such, may be installed with the hydraulic cabinets in hazardous zone 1 or 2 areas of the service station.

Non-ATEX certified Tokheim AdB dispensers must NOT be installed in hazardous zones 1 or 2 of the service station.

The following zoning diagram is a recommendation for the installation of non-ATEX certified dispensers on service stations where petrol dispensers are present.

Note : The diagram is a guideline only and all local and/or national prevailing regulations must be apply at all times.

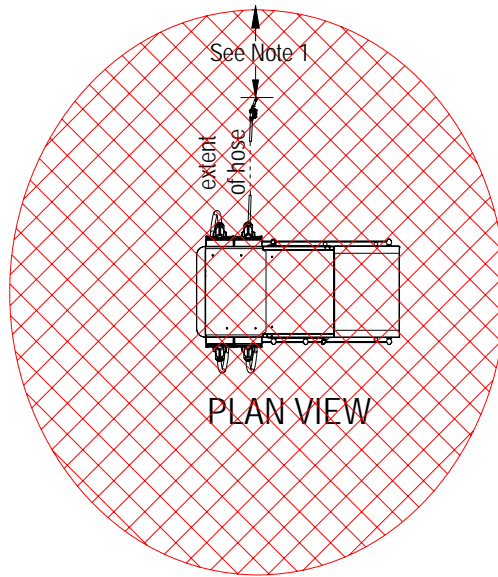

 Non-ATEX certified AdBlue
 ® dispensers must NOT be
 installed within this area

Petrol/Diesel
Dispenser

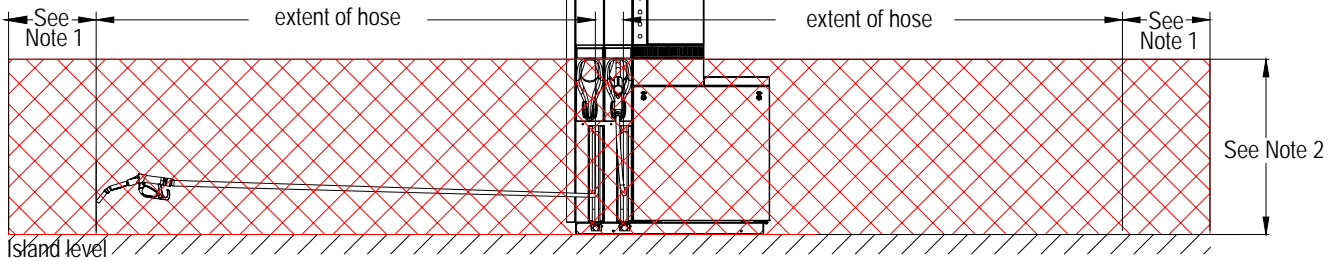

Note 1 :
 0.5m for Typical (except France & Germany)
 1.0m for France & Germany

Note 2 :
 1.0m for Typical (except France & Germany)
 Height of Vapour Barrier for France & Germany



FRONT ELEVATION

2.1.3 MINI COMBO ZONING DIAGRAM

-  Zone 1: Possibility of vapour release during dispenser operation.
-  Zone 2: Possibility of accidental vapour release.
-  Non-hazardous Zone.

* Zones 1 & 2: Only Atex approved components must be used.

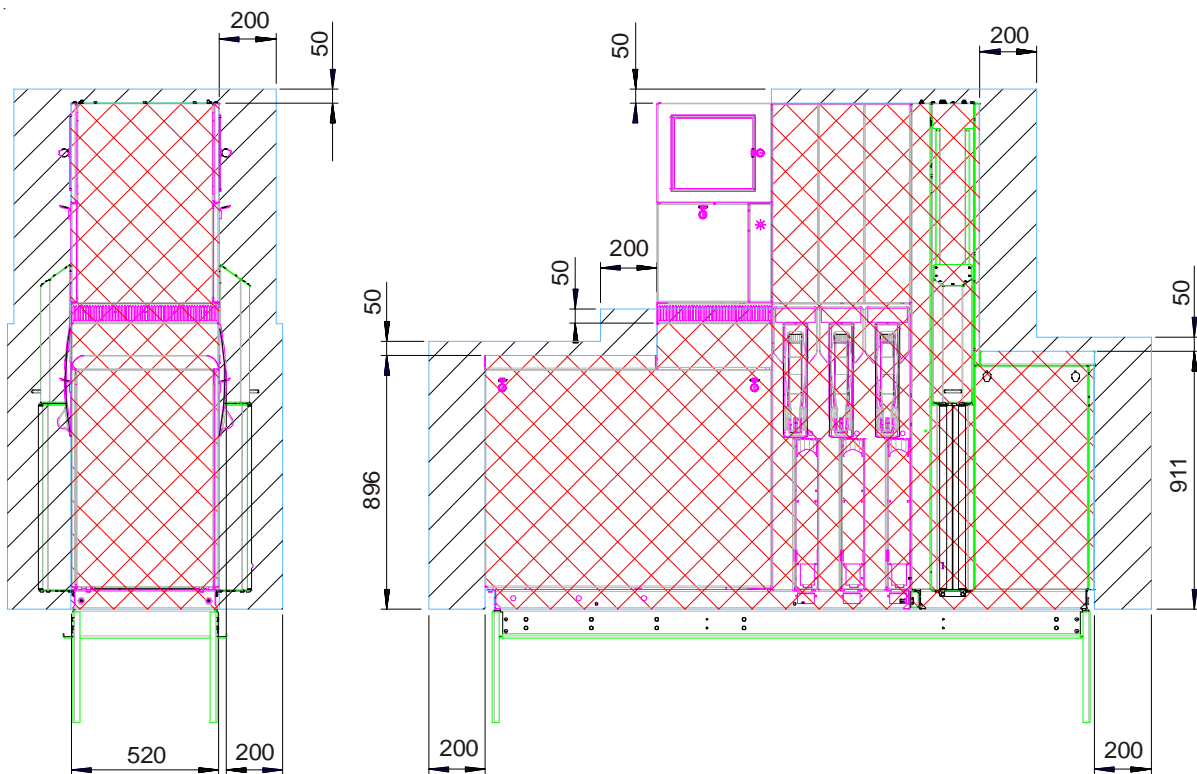

2.2 Basic Model Schematics

KEY



TM80 AdB Meter



Non-return valve (with relief)



WWC T1 Display



Solenoid Valve

cp

Combo Prepared AdBlue ® dispenser for connection to existing Tokheim dispenser



Submerged Pump in Container

t

AdBlue ® tank (container) unit

2.2.1 STANDALONE ADB MODELS

Model AdB 1-1, 1-1cp

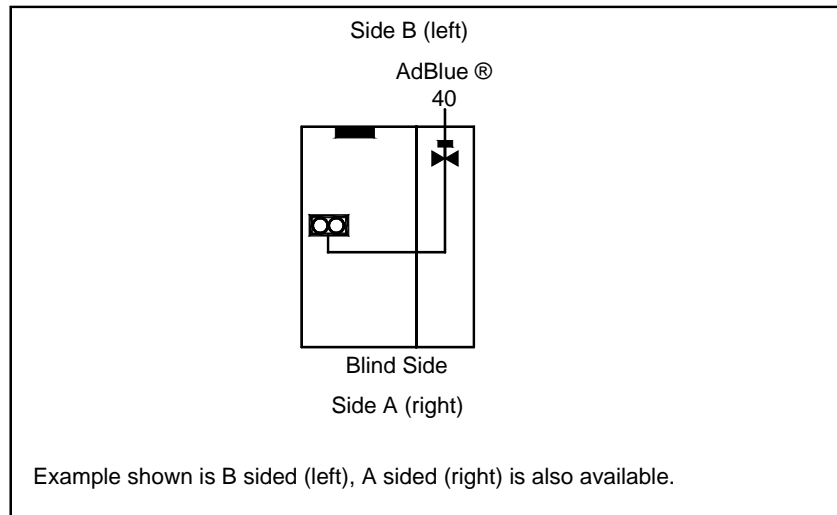

Model AdB 1-2, 1-2cp

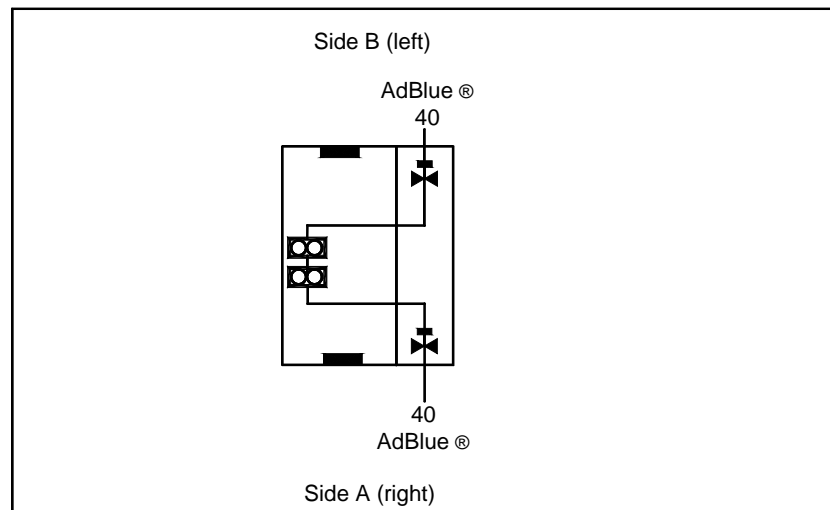

2.2.2 ADB WITH CONTAINER MODELS

Model AdB 1-1t

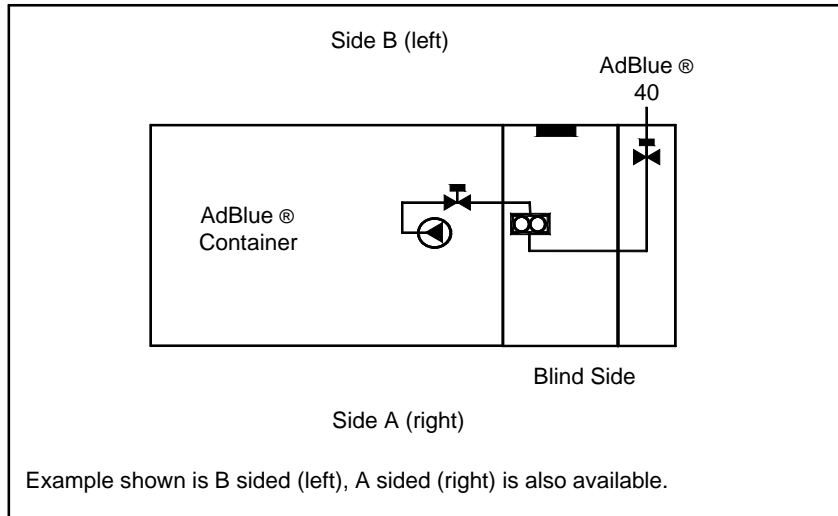

Model AdB 1-2t

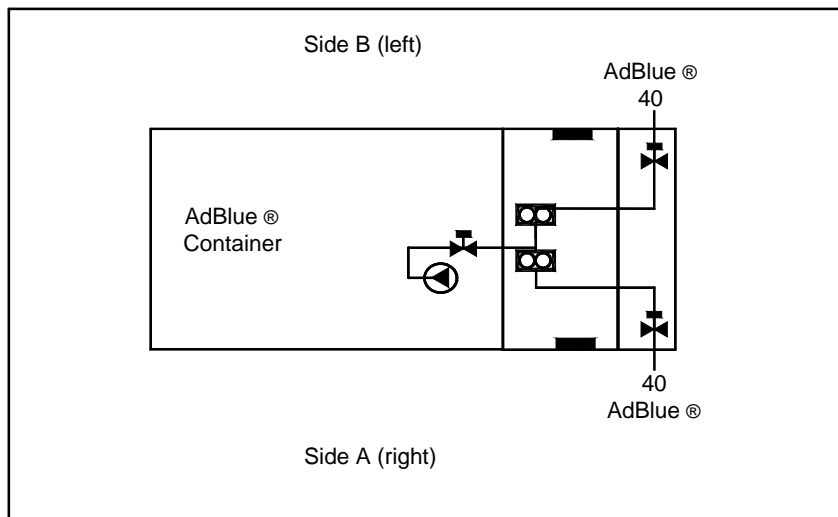

2.3 Mini Combo Schematics

KEY



TM80 AdB Meter



WWC T1 Display



Non-return valve (with relief)

t

AdBlue® tank (container) unit



Solenoid Valve



Submerged Pump in Container



PAS V3 Pump

PAS

2.3.1 STANDALONE MINI COMBO MODELS

Model 1-1 MCP with VHS 1-1

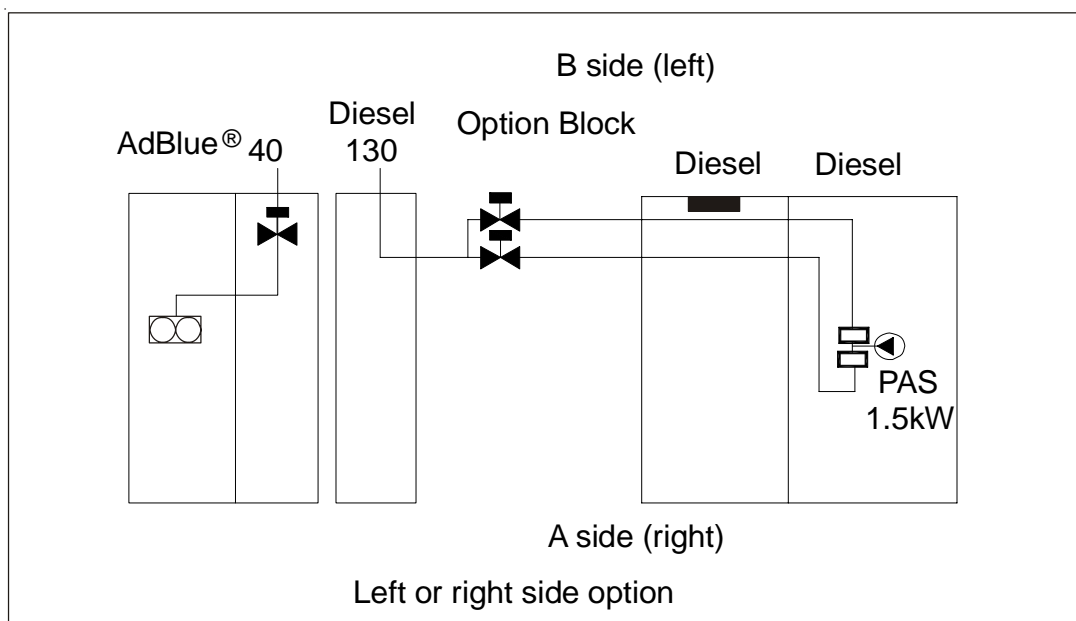

Model 1-2 MCP with VHS 1-2

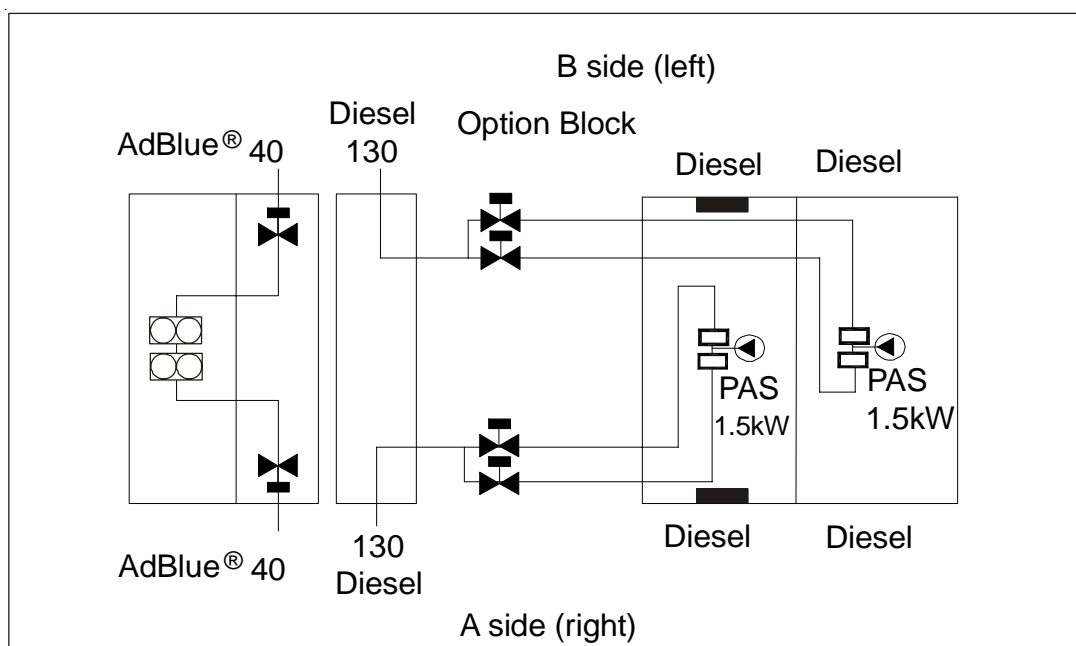

Model 1-2 MCP with VHS 2-4

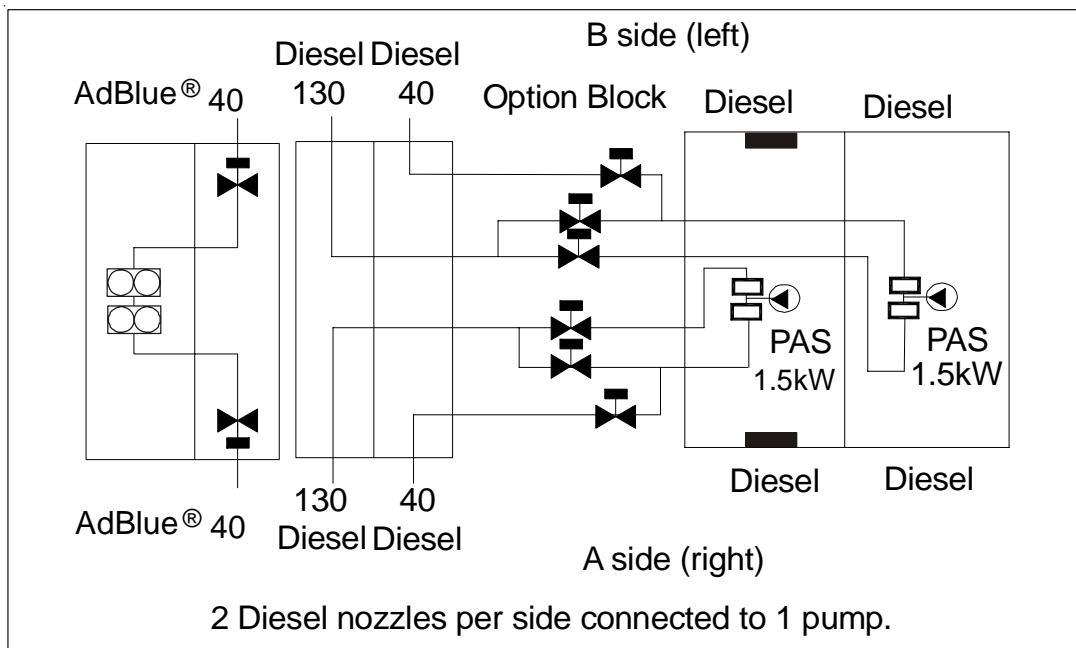

Model 1-2 MCP with VHS 3-6

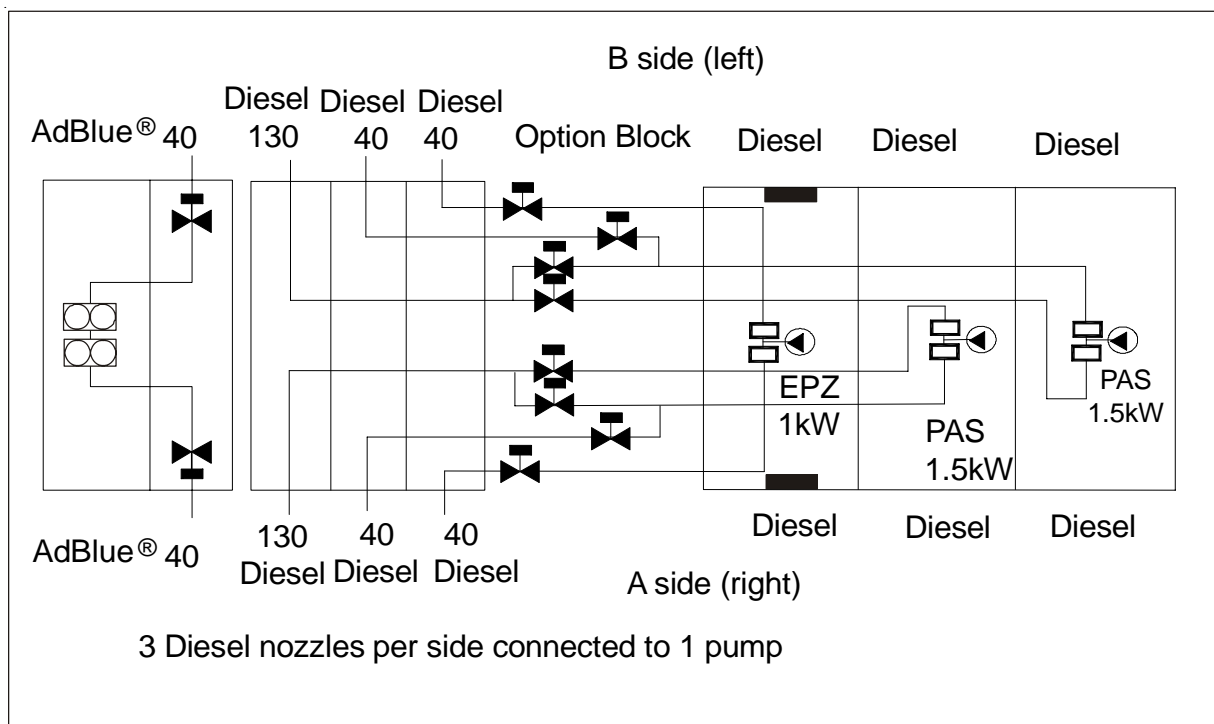

2.4 Hydraulic Connections - AdBlue® only

The AdBlue® filter box and AdBlue® riser pipe are accessible from side A of the dispenser. See section 5.2 for the identification of the dispenser sides.

Different types of hydraulic connection are available depending on the dispenser configuration and options ordered.



WARNING:- ALL INSTALLATION PIPEWORK AND FITTINGS MUST BE MANUFACTURED FROM ADBLUE® COMPATIBLE MATERIALS. GALVANISED STEEL IS NOT SUITABLE. TOKHEIM RECOMMENDS STAINLESS STEEL 316.

2.4.1 RECOMMENDED RISER HEIGHT FOR ADBLUE®

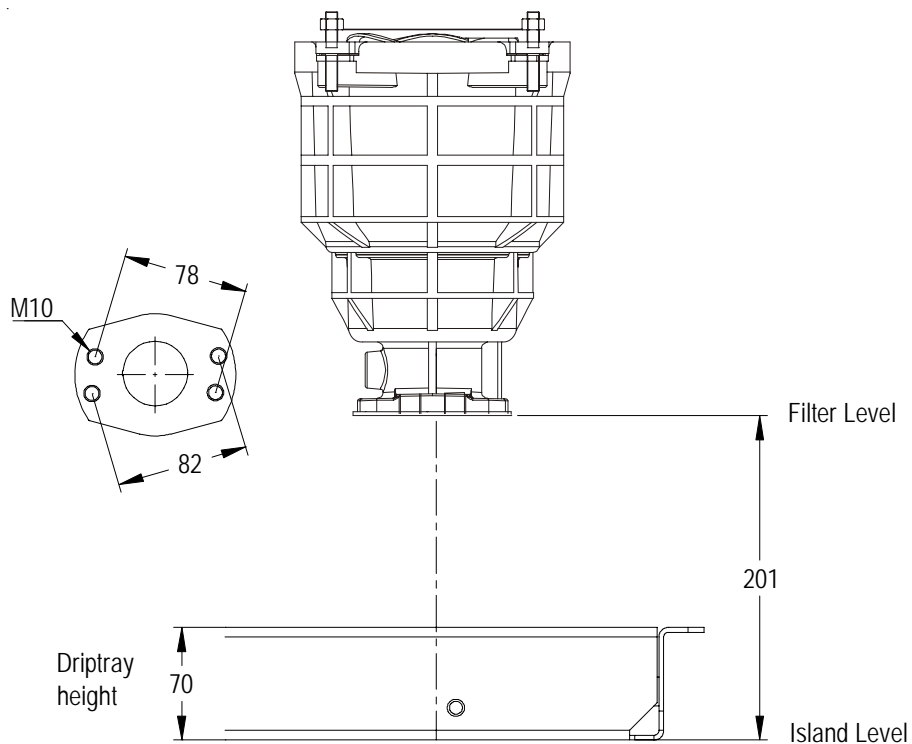

**Note : Installer to supply a suitable AdBlue® riser pipe.
Tokheim recommends the use of Stainless Steel 316.**

2.4.2 SUBMERGED CONNECTION FOR ADBLUE® - G1.5" SST

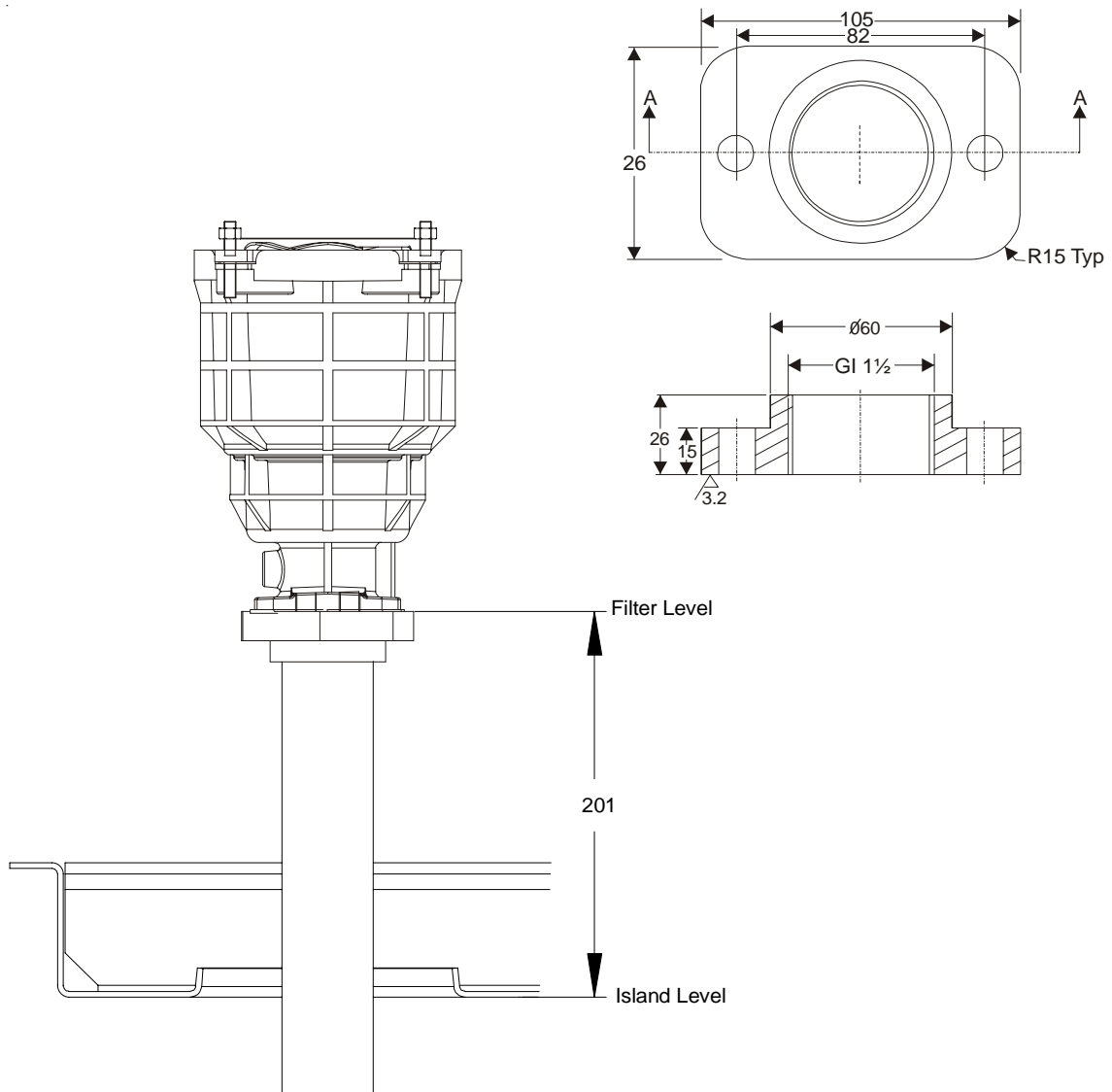

Note : Ensure the orientation of the flange matches the fixing holes of the filter pot at the correct height. (201mm)

2.5 Electrical Connections

The electrical connection to be established between the kiosk and the dispenser exists in different configurations. The mains connection (power from the mains supply panel to the dispenser) and the data connection (link between forecourt controller and calculator) are customer, country and configuration specific. The number of cores and the cross section of the cable will be specified, as will the cable construction (armoured or Explosion proof) and guidance ducts, channels or cable trunks have to be carried out in accordance with national technical regulations.

This page is intentionally blank

CONTENTS

3	DRAWINGS	3-2
3.1	Dispenser Dimensions	3-2
3.1.1	Standalone AdBlue ® only - Models AdB 1-1, 1-1cp, 1-2, 1-2cp	3-2
3.1.2	AdBlue ® & Container - Models AdB 1-1t & 1-2t	3-3
3.1.3	Mini Combo - Model AdB MCP with VHS	3-4
3.2	Ground Plans	3-5
3.2.1	Standalone AdBlue ® only - Models AdB 1-1, 1-1cp, 1-2, 1-2cp	3-5
3.2.2	AdBlue ® & Container - Models AdB 1-1t & 1-2t	3-6
3.2.3	AdBlue ® - Model AdB 1-1/1-2 MCP With VHS 1-1/1-2	3-7
3.2.4	AdBlue ® - Model AdB 1-2 MCP With VHS 2-4	3-8
3.2.5	AdBlue ® - Model AdB 1-2 MCP With VHS 3-6.....	3-9

NOTE:-

For CP models, refer also to relevant dispenser Installation, Maintenance and Parts Manuals as appropriate for dimensioned drawings and ground plans.

3 DRAWINGS

3.1 Dispenser Dimensions

3.1.1 STANDALONE ADBLUE[®] ONLY - MODELS ADB 1-1, 1-1CP, 1-2, 1-2CP

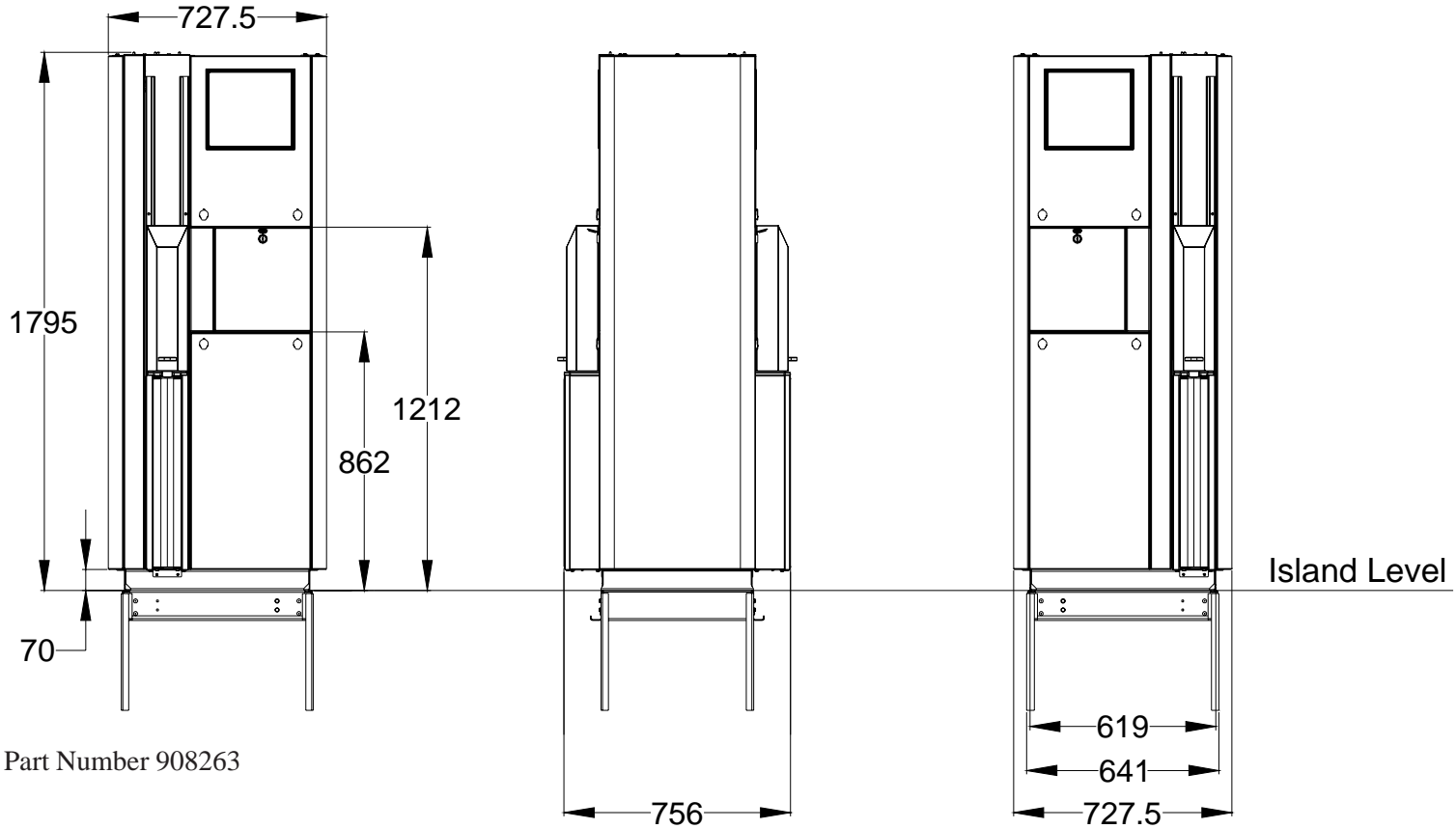
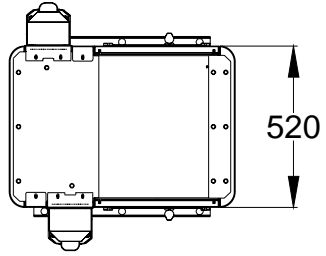

Ground Frame Part Number 908263

3.1.2 ADBLUE® & CONTAINER - MODELS ADB 1-1T & 1-2T

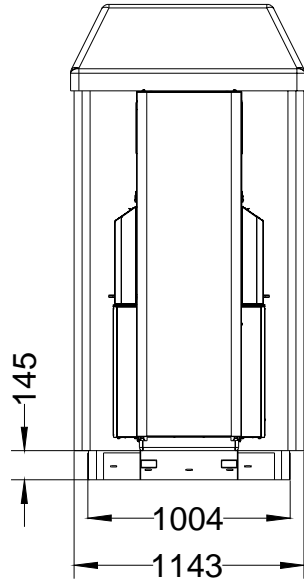
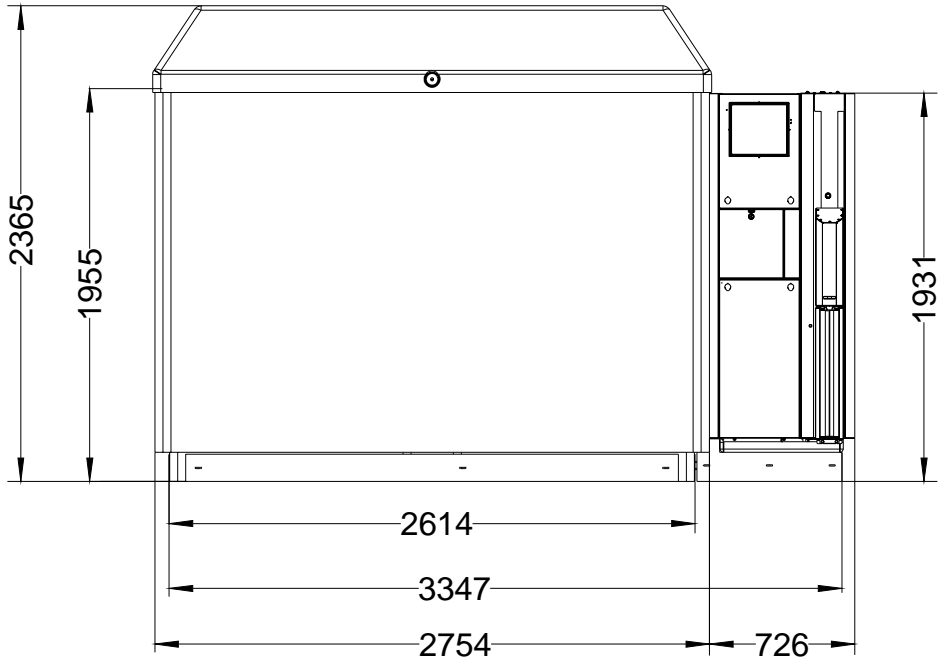
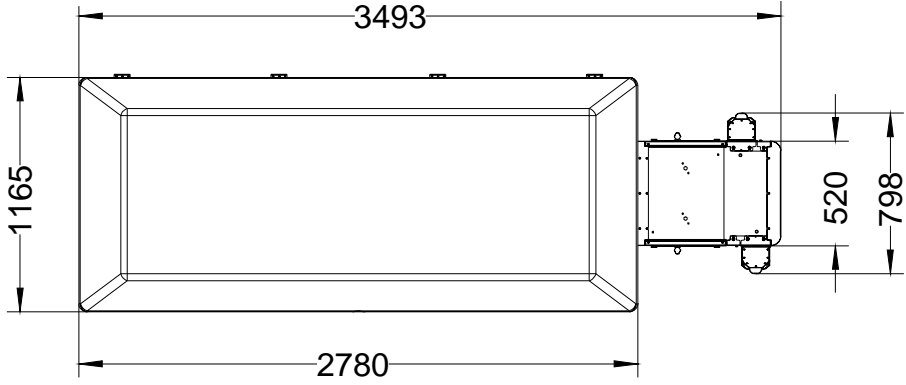

3.1.3 MINI COMBO - MODEL ADB MCP WITH VHS

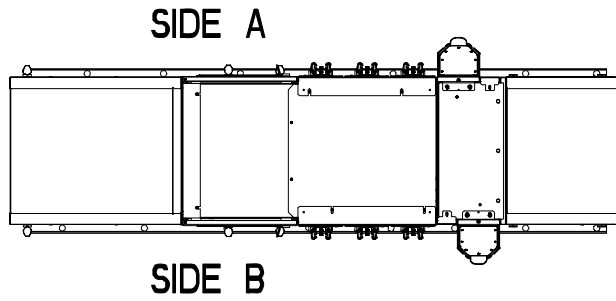

*
 For AdBlue 1-1/1-2 MCP with VHS 1-1/1-2, the Drip tray overall length is 1538mm
 For AdBlue 1-2 MCP with VHS 2-4, the Drip tray overall length is 1700.5mm
 For AdBlue 1-2 MCP with VHS 3-6, the Drip tray overall length is 2094mm

**
 For AdBlue 1-1/1-2 MCP with VHS 1-1/1-2, the Ground Frame overall length is 1557.5mm
 For AdBlue 1-2 MCP with VHS 2-4, the Ground Frame overall length is 1720mm
 For AdBlue 1-2 MCP with VHS 3-6, the Ground Frame overall length is 2113.5mm

 For AdBlue 1-1/1-2 MCP with VHS 1-1/1-2, the Cladding overall length is 1588mm
 For AdBlue 1-2 MCP with VHS 2-4, the Cladding overall length is 1750.5mm
 For AdBlue 1-2 MCP with VHS 3-6, the Cladding overall length is 2144mm

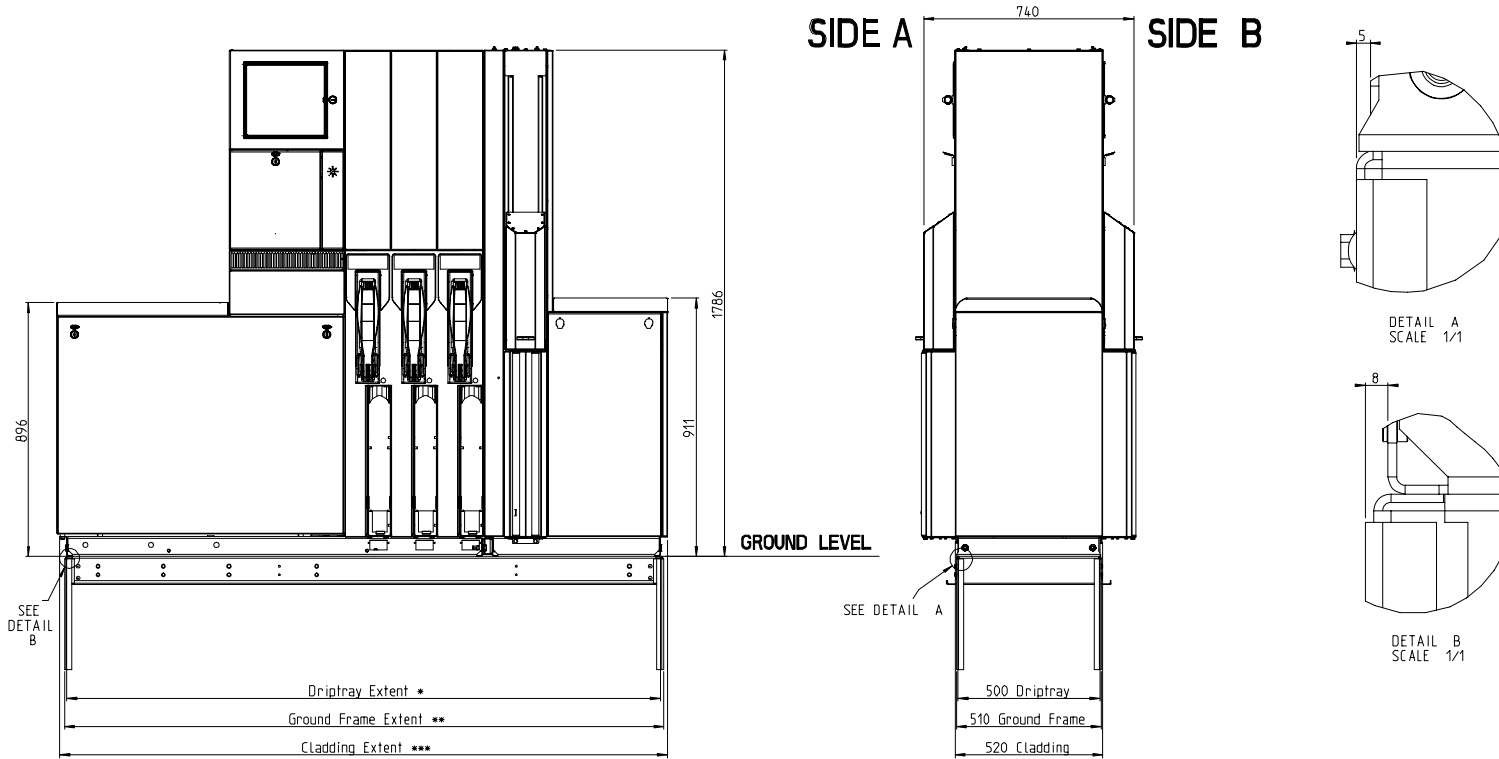

Note:
 Ground Frame Part Number:
 For AdBlue 1-1/1-2 MCP with VHS 1-1/1-2, use 944758-001
 For AdBlue 1-2 MCP with VHS 2-4, use 944758-002
 For AdBlue 1-2 MCP with VHS 3-6, use 944758-003

3.2 Ground Plans

3.2.1 STANDALONE ADBLUE[®] ONLY - MODELS ADB 1-1, 1-1CP, 1-2, 1-2CP

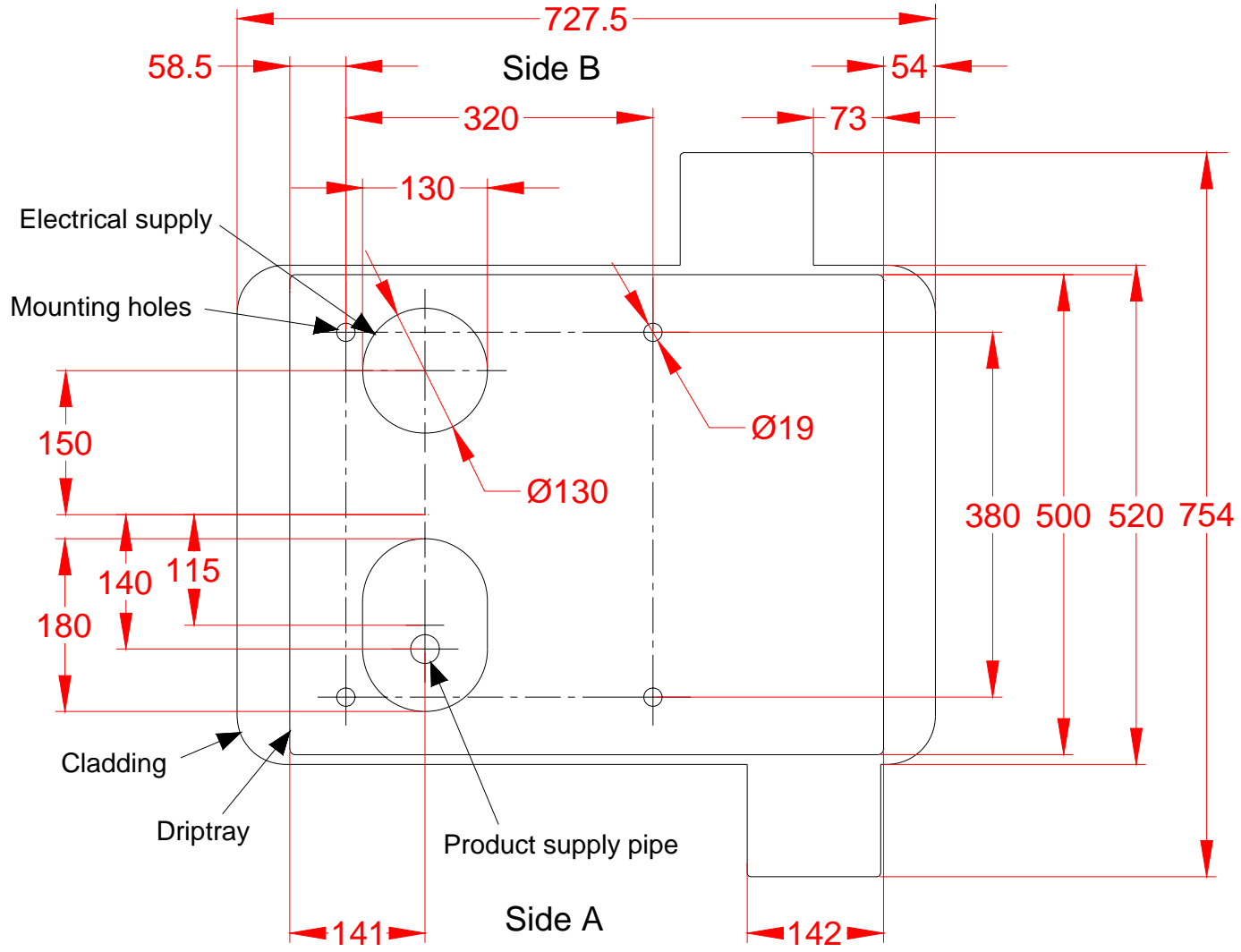

3.2.3 ADBLUE® - MODEL ADB 1-1/1-2 MCP WITH VHS 1-1/1-2

Plan View

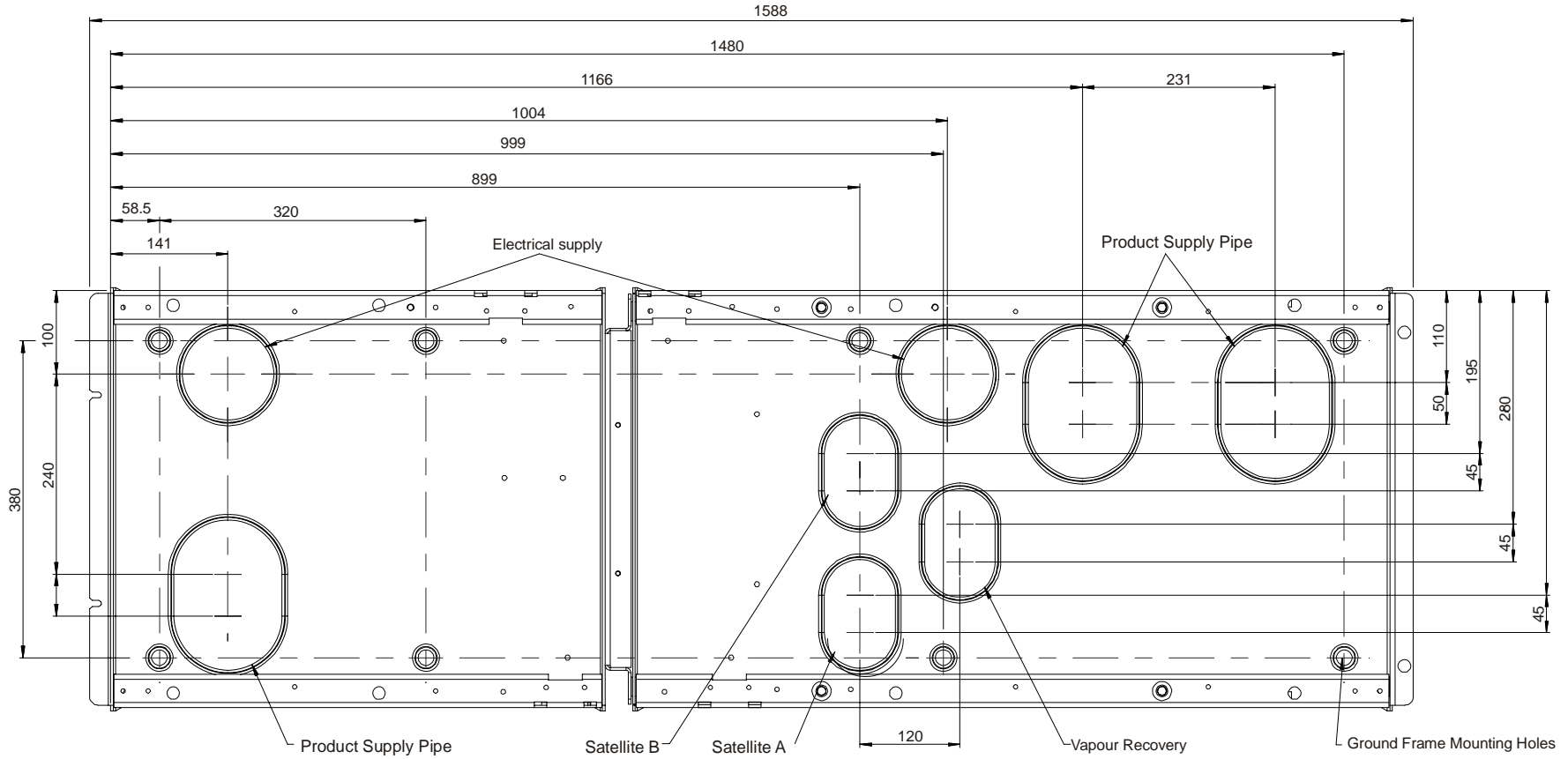

3.2.4 ADBLUE® - MODEL ADB 1-2 MCP WITH VHS 2-4

Plan View

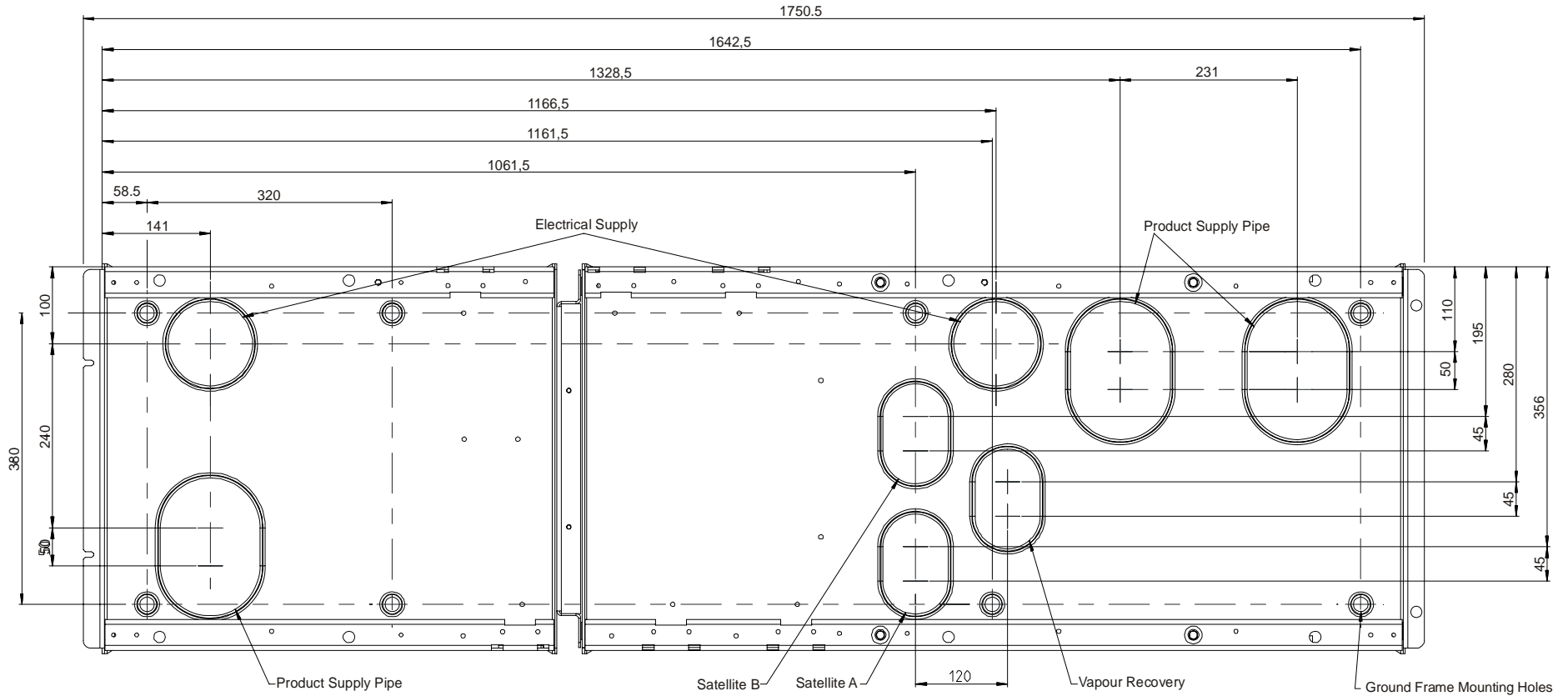

3.2.5 ADBLUE[®] - MODEL ADB 1-2 MCP WITH VHS 3-6

Plan View

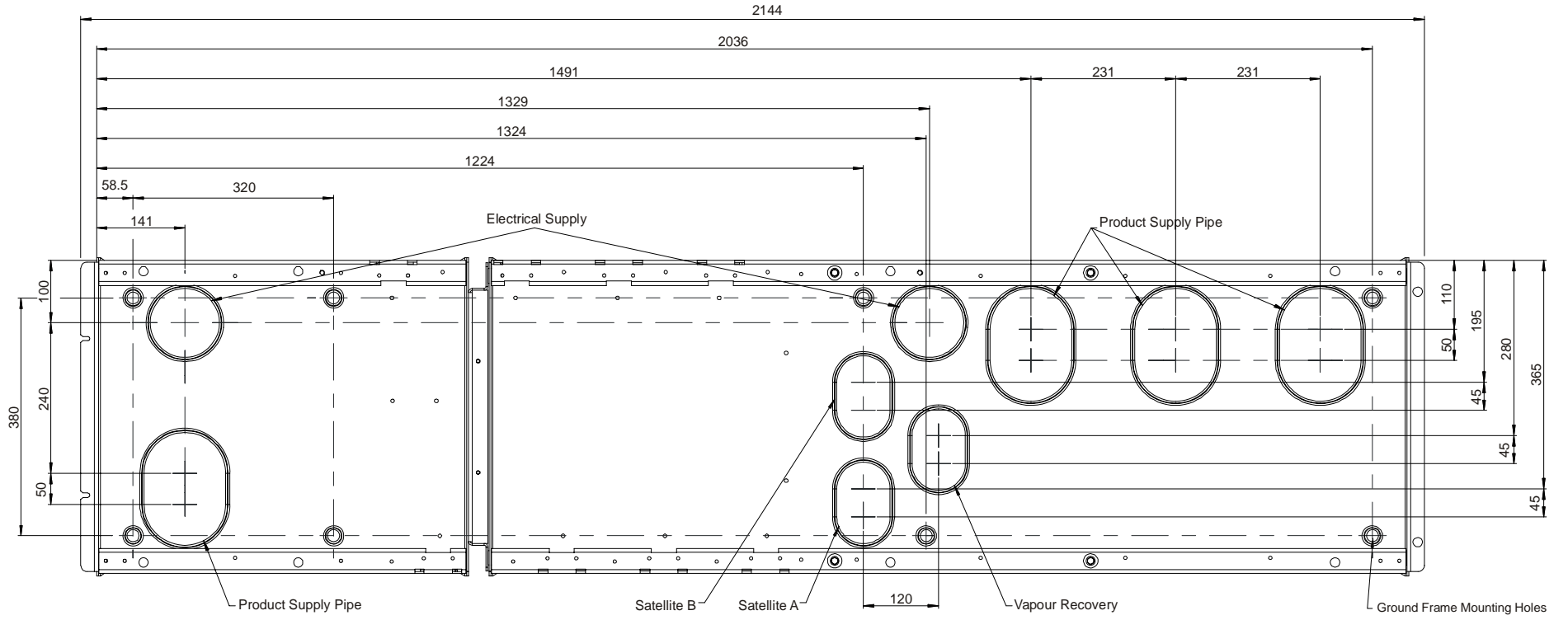

This page is intentionally blank

CONTENTS

4 PACKAGING & HANDLING 4-2

- 4.1 Shipping Documentation 4-2
- 4.2 Packaging 4-2
 - 4.2.1 Unpacking 4-2
- 4.3 Inventory Inspection 4-3
- 4.4 Weights 4-3
- 4.5 Handling 4-3
- 4.6 Access the Hydraulic Area 4-4
- 4.7 Access the Calculator Head 4-4
- 4.8 Access the DIT Spacebox/Glands 4-5
- 4.9 Accessing the Crypto VGA 4-6
- 4.10 Access the Container 4-6
- 4.11 CP Models - accessing the host dispenser 4-6

4 PACKAGING & HANDLING

4.1 Shipping Documentation

The following documents will accompany every delivery:-

- Shipping List
- Packing/Checking List
- CE Sticker
- Certificate of Conformity

The Serial Number on the dispenser should be identical to the Serial Number on the Shipping List, CE sticker and Certificate of Conformity. Please inform Tokheim before unpacking if there are any discrepancies in the notation.

4.2 Packaging

The type of packing depends on the destination of the goods. All products containing a frame are fixed on a pallet by means of screws and by the use of beams or blocks screwed onto the frame.

The goods are protected from moisture and scratching by bubble wrap and polystyrene corner blocks and a standard carton is generally used for packing. Where the use of a forklift truck or pallet truck is necessary, special arrangements make this possible through the use of pallets, beams, dispenser beam bridges or blocks.

All separate components belonging to the same delivery are packed together.

TOKHEIM ADBLUE ® CONTAINER

The container unit is **not** placed upon removable pallets. The container base frame consists of plastic pallets which form part of the unit and **cannot** be removed. The container unit has a large cover over the complete unit inside which the foam protection parts are included. The plinth parts are packed inside the top cover of the container unit.

4.2.1 UNPACKING

When the dispensers arrive at the installation site, the unpacked units should be inspected for possible shipping damage. If damage is evident, it must be reported to the carrier. Shipping damage is not covered under the Tokheim warranty policy.

After checking the equipment, the dispenser may be unwrapped. Cladding is packed in such a way that paint, screening and stickers are protected. Take care when unwrapping so that these elements are not damaged.

After unwrapping, the dispensers must be checked for any faults or damage. Any faults or damage found must be reported to the Installation Supervisor immediately.

Make sure that all packing materials are removed from the service station. It is recommended that you discuss this with the station's supervisor.

4.3 Inventory Inspection

After unpacking and prior to installation, the delivered equipment should be inspected to ensure that all the required materials are on hand, and the dispensers have all the ordered options and markings. If discrepancies in dispenser options and markings are evident, contact Tokheim.

4.4 Weights

Approximate weight per dispenser type:-

- Standalone AdB dispenser (1-2 hoses): 270 kg
- AdB dispenser & Container (1-2 hoses): 1100kg
- AdB Mini Combo (1-2 hoses): TBD
- AdB Mini Combo (2-4 hoses): TBD
- AdB Mini Combo (3-6 hoses): TBD

PLEASE NOTE : THE ABOVE WEIGHTS ARE APPROXIMATE AND WILL VARY ACCORDING TO OPTIONS FITTED.

4.5 Handling

The installer must supply all handling equipment and ensure safe working practice at all times.



The recommended procedure for safe handling of the standalone AdB dispenser is by use of a forklift under the pallet.

The recommended procedure for safe handling of the AdB dispenser & Container is by use of a forklift through the designated slots in the base frame.



Suitably rated cranes and/or HIAB`s can also be used at the installers own risk.



NOTE:-

For MiniCombo models, refer to Q500T1 dispenser Installation, Maintenance and Parts Manuals as appropriate for the hydraulic and electronic connection drawings.

4.6 Access the Hydraulic Area

The following instructions detail the procedure to be followed for the removal of the hydraulic door(s) to allow safe access to the dispenser AdBlue ® hydraulics.

- 1) Locate the keys for the hydraulic door.
- 2) Simultaneously open both keylocks on the relevant hydraulic door.
- 3) Where fitted, disconnect the earth cable and/or retaining cord from the hydraulic door.
- 4) Lift up the hydraulic door to release the locating pins from the holes in the drip tray.
- 5) Remove the door completely and place in a safe position.
- 6) Repeat for the opposite side of the dispenser as required.
- 7) To refit, insert the locating pins on the bottom of hydraulic door into the designated holes in the drip tray.
- 8) Where removed, re-connect the earth cable and/or retaining cord.
- 9) Simultaneously close both keylocks and remove keys for safe keeping ensuring the filler cap ring (where fitted) lies flat before closing hydraulic door.
- 10) Close the dust caps to prevent water or dirt entering the keylock.



4.7 Access the Calculator Head

The following instructions detail the procedure to be followed to allow safe access to the calculator head.

- 1) Locate the keys for the calculator head door.
- 2) Simultaneously open both keylocks on the relevant calculator head door.
- 3) Carefully open the calculator head door.
- 4) Secure the calculator head door in the open position by inserting the lever into the slot provided.
- 5) Repeat for the opposite side of the dispenser as required.
- 6) To close the calculator head door, ensure all cables remain inside, close and simultaneously close both keylocks on the calculator head door and remove keys for safe keeping.
- 7) Close the dust caps to prevent water or dirt entering the keylock.



4.8 Access the DIT Spacebox/Glands

The following instructions detail the procedure to be followed to allow safe access to the DIT spacebox/glands.

1) DISPENSERS WITH DIT ONLY

- Open the keylock on the integrated DIT panel.
- Open the drawer and disconnect the two connectors.
- Remove the drawer completely and place in a safe position.



DISPENSERS WITHOUT DIT

- Unlock the blind DIT door.
- Where fitted, disconnect the earth cable from the door.
- Remove the door completely and place in a safe position.



WARNING : Do not drop the door - the DIT door is not hinged nor secured by a retaining cord.



2) Repeat for the opposite side of the dispenser as required.

3) To re-fit:-

DISPENSERS WITH DIT ONLY

- Re-connect the two connectors.
- Position DIT drawer onto rails, slide back into the dispenser and lock.
- Remove key for safe keeping and close the dust cap.

DISPENSERS WITHOUT DIT

- Position blind DIT door onto the dispenser.
- Where removed, re-connect the earth cable and lock in position.
- Remove key for safe keeping and close the dust cap.

4.9 Accessing the Crypto VGA

Access to the Crypto VGA unit is the same for standalone Outdoor Payment Terminals (OPTs) as for Dispenser Integrated Terminals (DITs).

Swipe the Maintenance/Service card at the Service Station Point of Sale (POS) or terminal and select the option Maintenance/Service mode before attempting to access the OPT/DIT.

Note : A spanner on the display indicates the terminal is in Maintenance/Service mode.

DISARM THE ELECTRONIC LOCK

- Press first the spanner and then 'Ticket' on the OPT/DIT screen to disarm the electronic lock
- An audible alarm is sounded to alert the unit is open
- Pull the printer unit open

Note : The red open padlock on the display indicates the drawer is open and unalarmed.

- Close drawer to electronically lock



4.10 Access the Container

The AdBlue ® Dispenser with Container will be shipped as a single unit. The container unit will always be transported empty of AdBlue ® and with the cladding panels on (except the plinth panels which are packed inside the container lid). All pipework and cabling between the container and dispenser will be connected before shipment.

The Container is filled via a filling nozzle and valve unit in the AdBlue ® hydraulic cabinet. The AdBlue ® Container must NEVER be accessed by unauthorised personnel. Contact your nearest Tokheim service organisation as given on the back cover of this manual.

4.11 CP Models - accessing the host dispenser

For CP models, refer also to relevant dispenser Installation, Maintenance and Parts Manuals as appropriate for access information.

CONTENTS

5 INSTALLATION 5-2

5.1 General 5-2

5.2 Identification of Side A 5-2

5.2.1 Standalone AdB only dispensers 5-2

5.2.2 CP Models 5-3

5.2.3 Container & AdB dispensers 5-3

5.3 Lifting 5-4

5.4 Placement 5-4

5.4.1 Standalone AdB only - By Forklift 5-5

5.4.2 CP Models - By Forklift 5-7

5.4.3 Container & AdB Dispensers - By Forklift 5-7

5.4.4 Fixing to Ground 5-9

5.4.5 Earthing 5-10

5.5 Hydraulic Connections 5-11

5.5.1 AdBlue ® Pipework 5-11

5.6 Filling the AdBlue ® Container 5-12

5.6.1 Instructions for Tokheim AdBlue ® Containers 5-12

5.6.2 Instructions for Customer Specific 1 AdBlue ® Containers 5-13

5.6.3 Leak Detection systems 5-14

5.7 Heating Systems 5-15

5.7.1 Non-ATEX Heating Overview 5-15

5.7.2 ATEX Electric Heating Overview 5-16

5.7.3 ATEX Water Heating Overview 5-17

5.7.4 Filling and Priming the Water Heating System 5-18

5.8 Electrical Connections - General 5-19

5.8.1 Main M2000 Junction Box Wiring 5-19

5.9 AdB Standalone & AdB Container Dispensers 5-21

5.9.1 Position of Junction Boxes in AdB dispensers 5-21

5.9.2 No Heating & Non-ATEX Heating 5-22

5.9.3 ATEX Electric Heating 5-24

5.9.4 ATEX Water Heating 5-25

5.10 AdB dispensers 5-26

5.10.1 Position of Junction Boxes in AdB CP & Host dispensers 5-27

5.10.2 No Heating & Non-ATEX Heating 5-28

5.10.3 ATEX Electric Heating 5-34

5.10.4 ATEX Water Heating 5-36

5.11 Electrical Options 5-38

5.11.1 Fire and/or Shock Detection 5-38

5.11.2 Audio/Speaker 5-38

5.11.3 Sliding Door and/or Low Temperature Alarm 5-39

5.11.4 Special Dispenser Configurations 5-39

5.12 Communications Wiring in Main Junction Box 5-40

5.13 Current ratings for AdBlue dispensers 5-43

5 INSTALLATION

5.1 General

Before the dispenser can be installed, the Safety Instructions as described in Section 1.5 and the Installation Instructions in this section must be carefully read.

Follow unpacking instructions in Section 4.2.1.

After unwrapping and before installation, the dispensers must be checked for any faults or damage. Any faults or damage found must be reported to the Installation Supervisor immediately.

NOTE: FOR SUBMERGED PUMPS, THE CONTROL MUST BE COMPLETELY ISOLATED DURING ALL PHASES OF INSTALLATION.

The following checks need to be made before starting the installation :-

- Check that the electric cabling and the piping arrangements have been made in accordance with the Installation drawings in section 3.
- Where fitted, check that the ground frames have been installed in accordance with the Installation drawing. Any differences or defects should be reported to the Installation Supervisor immediately.
- Where applicable, check that all flame arresters are correctly installed according to the drawings.

5.2 Identification of Side A

5.2.1 STANDALONE ADB ONLY DISPENSERS

The different sides of the Standalone AdB dispenser, including CP models, as referred to in this manual are described as follows:-



- Side A of the dispenser has the hose at the right hand side. With the hydraulic door removed, side A has the filter box and access to the AdBlue ® riser pipe.

- Side B of the dispenser has the hose at the left hand side. With the hydraulic door removed, side B has the junction box and access to the electrical cables.

5.2.2 CP MODELS

For CP models, refer also to relevant dispenser Installation, Maintenance and Parts Manuals as appropriate for relevant information. Follow instructions for Standalone AdBlue® dispensers for placement.

5.2.3 CONTAINER & AdB DISPENSERS

The different sides of the Container & AdB dispenser referred to in this manual are described as follows:-

- Side A of the dispenser has the hose at the right hand side. With the hydraulic door removed, side A has the filter box and access to the AdBlue® riser pipe.



- Side B of the dispenser has the hose at the left hand side. With the hydraulic door removed, side B has the junction box and access to the electrical cables.



5.3 Lifting

The responsibility for carrying out the procedures described in this manual lies with the persons lifting and placing the dispenser.

The installer must supply all lifting equipment and ensure safe working practice at all times.

The Standalone AdB and CP dispensers can be lifted by forklift truck under the pallet.

The AdB & Container dispenser can be lifted through the forklift slots in the base frame.



WARNING : ENSURE ALL LIFTING EQUIPMENT (FORKLIFT TRUCK, CRANE, LIFTING STROPS ETC.) ARE RATED TO A MINIMUM LIFTING CAPACITY OF 1500KG AT A DISTANCE OF 1.5M.

To reduce the risk of injury, keep lifting height to a minimum and ensure the area is clear of personnel during the lifting and placement of the dispenser.

5.4 Placement

Before placement on the island can take place, the following procedures must be carried out:-

- Check that the electric cabling and piping arrangements have been made in accordance with the Installation drawing
- Check that all installation pipes and fittings are manufactured from AdBlue® compatible material.
- Check the pipes have been flushed before connecting the hydraulic components (if necessary, contact the tank installer)
- Removal of stop plugs on fuel and vapour recovery pipes
- Preparation of mounting frame

Note : Ensure all mounting holes in the ground frame are free from debris and that the island is flat and clear from debris.

- Fitting of seals for cable, fuel and vapour recovery pipe access
- Sealing of non-used holes

IMPORTANT - Ensure Side A of the dispenser is positioned onto the island per customer specifications. See Section 5.2 for locating Side A.

5.4.1 STANDALONE AdB ONLY - BY FORKLIFT

Follow the instructions in section 4.6 to gain access to the dispenser hydraulic area.

- 1) Lift the dispenser using a forklift truck under the pallet.

Position the dispenser adjacent to the dispenser island.



- 2) Determine side A of the dispenser. Remove the hydraulic doors on both sides of the dispenser.



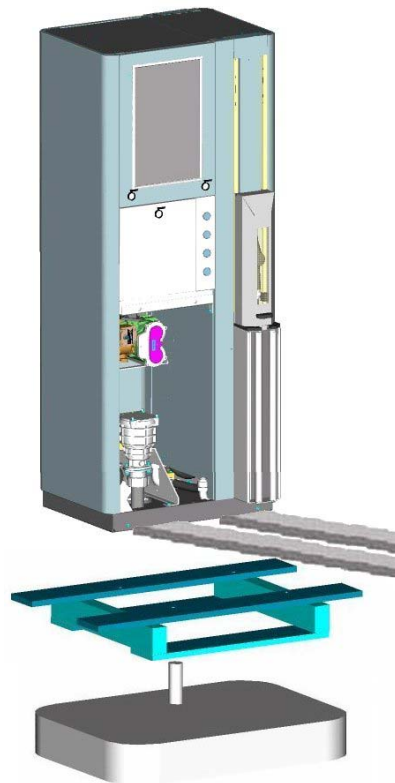

- 3) Carefully lift the dispenser and unbolt the pallet and remove completely.

Note : Do not suspend the dispenser for any longer than necessary.

- 4) Position the dispenser on the island ensuring the riser pipes and electric cables pass through the correct holes in the drip tray.

Note : For CP models, place as close to host dispenser as possible leaving sufficient access to remove the side panels on both dispensers.

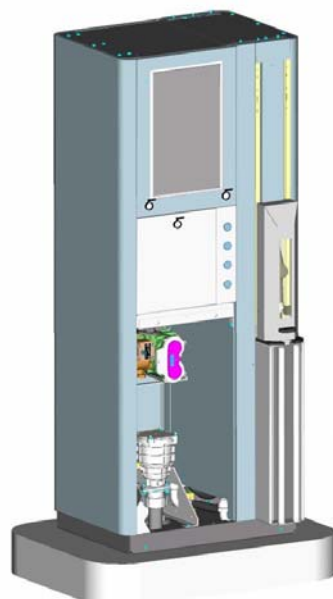

- 5) **IMPORTANT:-**
Secure the dispenser to the ground as described in section 5.4.4.

Placement complete.

5.4.2 CP MODELS - BY FORKLIFT

Follow the instructions in section 5.4.1 to lift and position the AdBlue ® dispenser close to the host dispenser.

IMPORTANT : WHEN POSITIONING THE ADBLUE ® DISPENSER BESIDE THE HOST DISPENSER, ENSURE THERE IS SUFFICIENT CLEARANCE TO ALLOW THE REMOVAL OF THE SIDE PANELS ON BOTH THE ADBLUE ® AND EXISTING DISPENSERS (FOR MAINTENANCE PURPOSES).

5.4.3 CONTAINER & AdB DISPENSERS - BY FORKLIFT

Follow the instructions in section 4.6 to remove the hydraulic doors on both sides of the dispenser to allow access to the dispenser hydraulic area.

- 1) Locate the designated lifting slots in the base frame (if these are not visible then remove the plinth parts around the base of the unit).

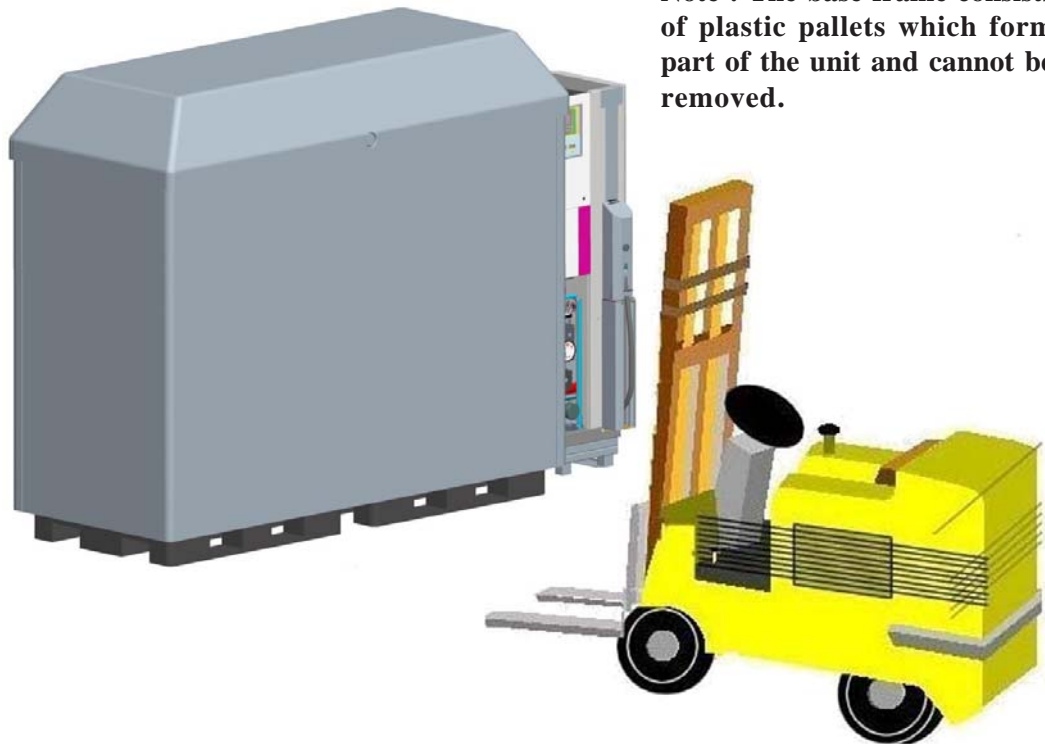

Note : The base frame consists of plastic pallets which form part of the unit and cannot be removed.

- 2) Determine side A of the unit. Lift the container and dispenser unit using a forklift truck through the slots in the container base frame.

Position the unit adjacent to the island or designated flat area for its location.

- 3) Carefully lift the unit and position on the island/ground ensuring the electric cables pass through the correct hole in the dispenser base frame.

Note : Do not suspend the unit for any longer than necessary.

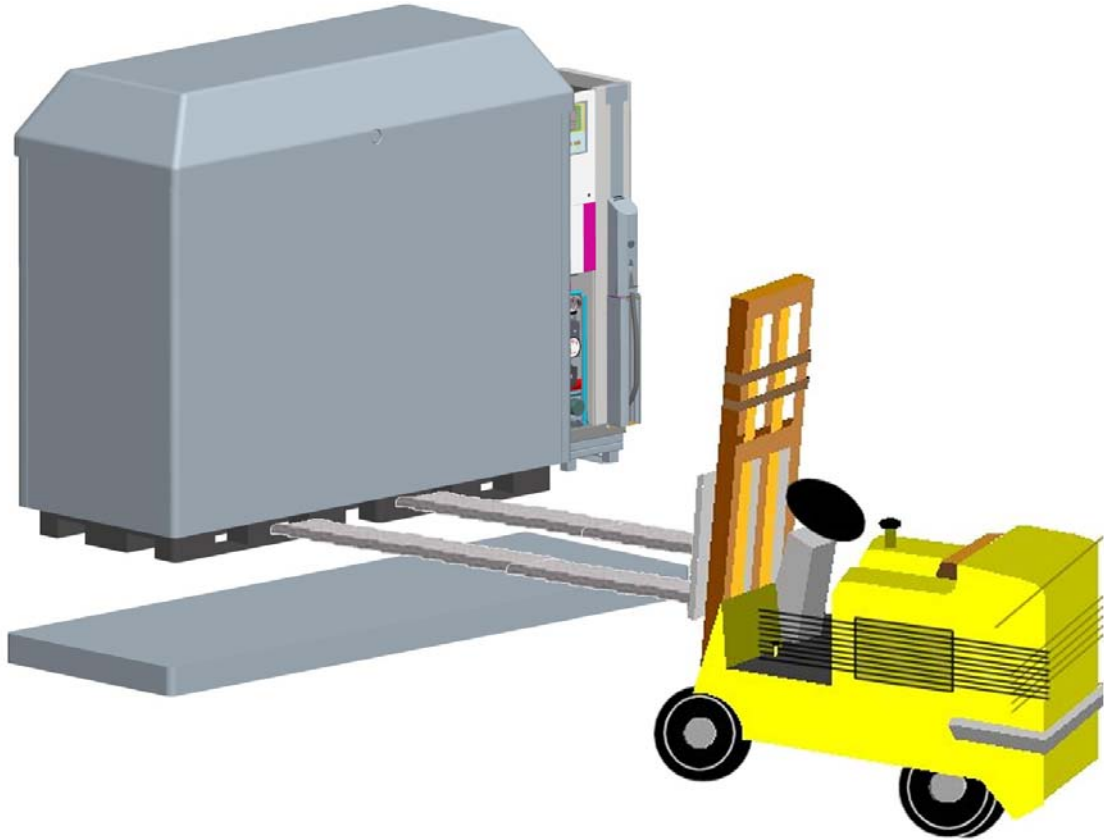

- 4) **IMPORTANT:-**
Secure the dispenser to the ground as described in section 5.4.4.
- 5) Cover the holes in the base frame by fitting the plinth parts to the unit and secure in position using the fixings provided.

Note : The plinth parts are packed inside the top cover of the container unit.

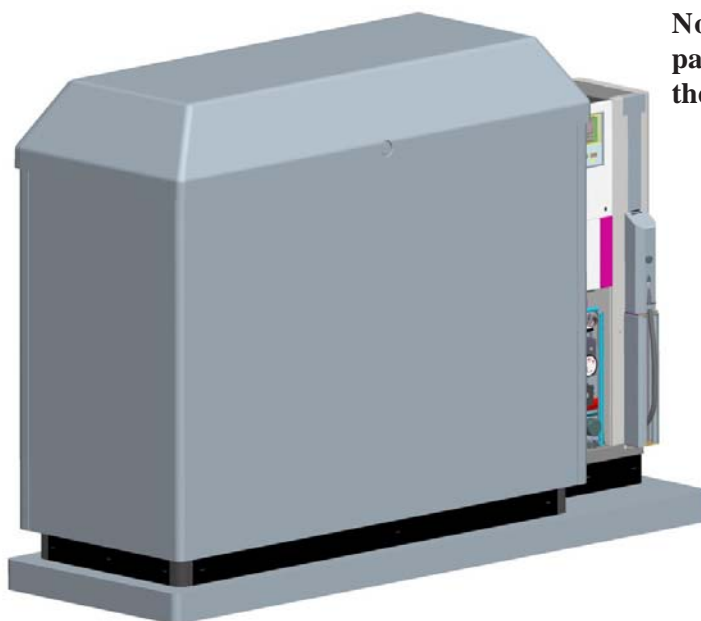

- 6) Placement complete.

5.4.4 FIXING TO GROUND

The following information relates to a typical Tokheim dispenser, unmodified by the user, with no additional advertisement boards, canopies or items added to the dispenser. Any such modifications may affect the stability and have warranty/liability consequences.

IMPORTANT:- Tokheim dispensers must be secured to the ground using all 4 mounting positions provided in the driptray - refer to the groundplan drawings in section 3 for mounting hole positions.

TYPICAL FIXING INTO CONCRETE (NO GROUNDFRAME)

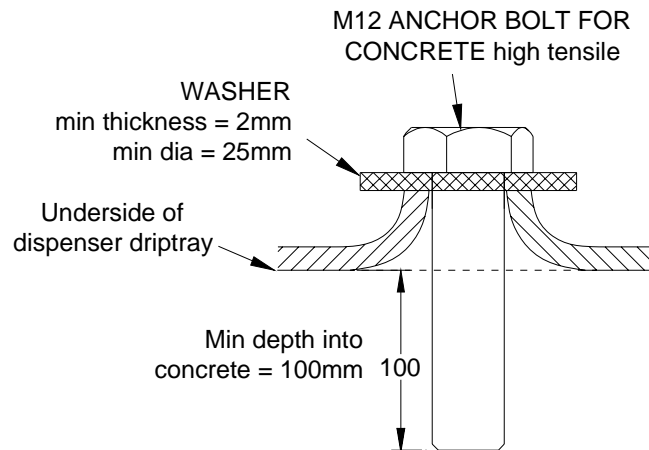

TYPICAL FIXING INTO TOKHEIM GROUNDFRAME

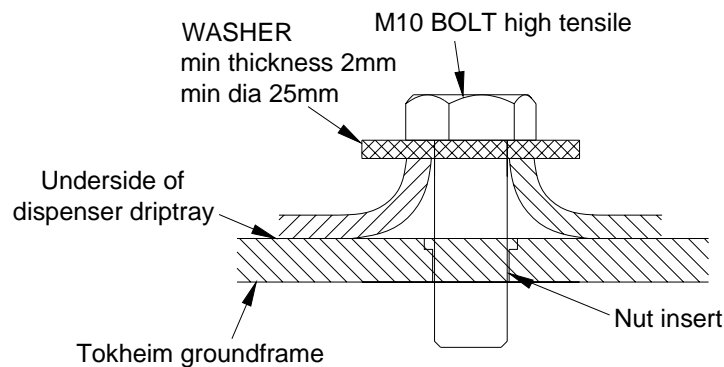

TYPICAL FIXING INTO THIRD PARTY GROUNDFRAME / SUMP FRAME

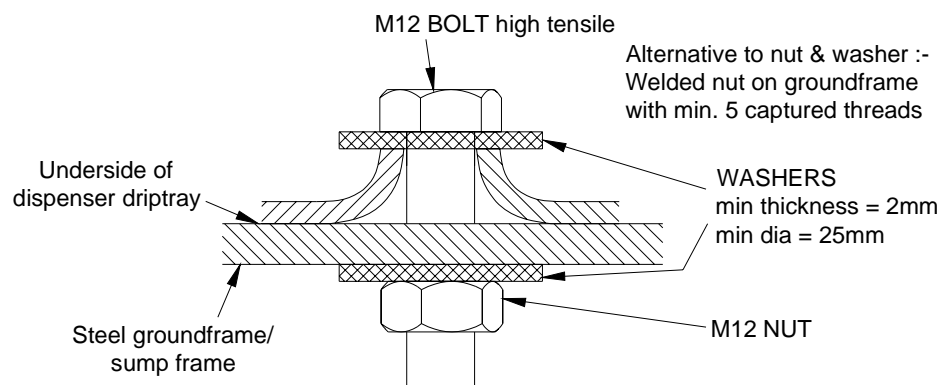

5.4.5 EARTHING

Earthing requirements are dictated by local National regulations and must always be observed.

Tokheim recommends the following guidelines as a **minimum requirement**:-

- 6mm² earth conductor(s) back to main site earth (up to 85m cable run)
- 10mm² earth conductor(s) back to main site earth (85 to 150m cable run)

The primary earth connection point for Quantum dispensers is the M2000T Junction Box provided for installation cable connections. Threaded inserts or studs (M8) are also provided in the base frame as an additional external connection facility for an earthing or equipotential bonding conductor.

Earthing requirements are dependent upon the number of earth conductors provided (one per power cable) and the types of cable used. For example, where steel wire armour cables or MICC are used in conjunction with the appropriate termination glands, no supplementary specific earth cable is likely to be required. Where simple PVC covered cables are used, Tokheim recommends an additional earth core is connected to the point provided on the dispenser base frame.

IMPORTANT : It is the responsibility of the installer to supply the earth wire and ensure the dispenser is safely earthed. This product will only be reliable and safe in use, if it is connected to a wall-outlet or mains terminal with a correct connection to safety earth.

Note : To detect any earth leakage current, it is strongly recommended that a residual current device (RCD) is fitted.

The photograph below is a typical example of an earth connection point on a Q500T1 dispenser (exact location and/or fixture may differ between dispenser ranges):-



5.5 Hydraulic Connections

Connect all hydraulic and electric junctions according to the specifications as described in this section and indicated on the drawings in Section 3.

Flow rates achieved are dependent upon the type of pumping system used and other site-specific conditions. **Note : The maximum pressure must not exceed 4 bar.**

Follow the instructions given in section 4.6 to gain access to the dispenser hydraulic area(s).

5.5.1 AdBlue ® PIPEWORK

All AdB dispensers are only available in submerged configuration.

Connections to the AdBlue ® supply pipes are accessible from side A of the dispenser (see section 5.2 for identification of sides).

The dispenser is positioned with the filter box positioned above the relevant supply risers. (see section 2.3 for recommended riser heights). If required, flanges (Pn. 943472) should be fitted to the supply pipes.



- 1) Remove the protective covers on the AdBlue ® supply riser pipe and on the filter box.

WARNING : BEWARE OF FUEL SPILLAGE.

- 2) Apply a thread sealant, eg: Loctite 577 or PTFE tape to the riser pipe thread.

- 3) Fit the flange to the AdBlue ® supply riser pipe.

- 4) Place the gasket on top of the flange and below the filter box.

- 5) Fit the flange to the filter box using the 2 screws provided in the installation kit.

- 6) Using a 15mm spanner or socket, tighten the two screws on the flange.



5.6 Filling the AdBlue ® Container



Warning : Remove all foam blocks placed between the inner and outer tank before filling up the container. These blocks are for transportation purposes only.

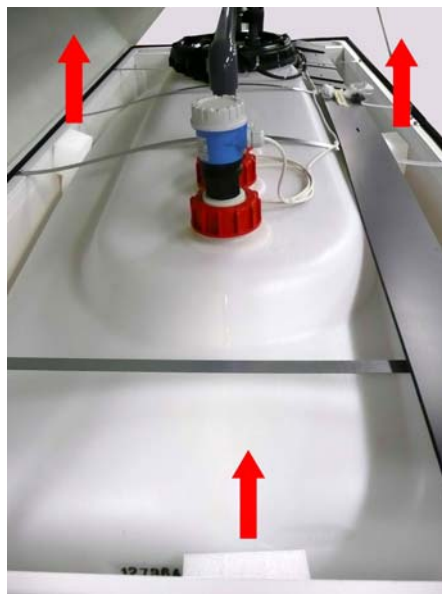

AdB & Container dispensers are self-contained units with pre-installed internal pipework between the container and the AdBlue ® dispenser. The AdBlue ® container is filled from an inlet connection located in the AdBlue ® dispenser hydraulics. Follow the instructions given in section 4.6 to gain access to the AdBlue ® dispenser hydraulic area(s).

NOTE : The following procedures may vary for dispensers with different filling control boxes and positions.

5.6.1 INSTRUCTIONS FOR TOKHEIM ADBLUE ® CONTAINERS

- 1) Locate the container filling inlet in the AdB side of the dispenser (above or below the container filling control box).
- 2) Remove the cover of the container filling inlet (retained by chain).
- 3) Connect the nozzle from the tanker to the container filling inlet using an adaptor if required.
- 4) Turn filling switch on the container filling control box to setting ‘1’ (filling valve red light on).
- 5) Commence filling from the delivery vehicle until the desired volume is reached or until the AdBlue ® container is full (whereby the maximum level sensor will automatically shut the filling valve and the red light will switch off).



WARNING : MAXIMUM PRESSURE AT DELIVERY VEHICLE $P_{max} = 1$ Bar (unless otherwise stated)

- 6) Empty the hose from the delivery vehicle by either holding down the 'Empty Hose' button or turning the 'Empty Hose' switch to setting '1' whilst allowing air to enter the hose at the delivery vehicle end to push the remaining AdBlue® liquid back through to the AdBlue® container (this overrides the maximum level sensor and the filling valve red light will come on whilst the button is depressed/switch set to 1).
- 7) When the hose is empty, release the 'Empty Hose' button or return the 'Empty Hose' switch to 0.
- 8) Return the filling switch to '0' setting if required.
- 9) Disconnect the delivery vehicle hose (and adaptor where fitted) from the container filling inlet and replace the filling inlet cover.
- 10) Refit the hydraulic door and lock ensuring the filler cap ring lies flat before closing the hydraulic door.



Note : If a display/gauge is present, this indicates the level of AdBlue® liquid in the container.

5.6.2 INSTRUCTIONS FOR CUSTOMER SPECIFIC 1 ADBLUE® CONTAINERS

- 1) Locate the container filling inlet in the AdB side of the dispenser (above or below the container filling control box).
- 2) Remove the cover of the container filling inlet (retained by chain).
- 3) Where fitted, connect the truck valve cable to the truck connector in the dispenser.
- 4) Connect the nozzle from the tanker to the container filling inlet using an adaptor if required. This will open the line for filling.



WARNING : MAXIMUM PRESSURE AT DELIVERY VEHICLE Pmax = 1 Bar (unless otherwise stated)

- 5) Commence filling from the delivery vehicle until the desired volume is reached or until the alarm is sounded to indicate the AdBlue® container is full.



WARNING : THERE IS NO OVERFILL PROTECTION - WHEN ALARM SOUNDS, STOP FILLING IMMEDIATELY AND EMPTY THE HOSE.

- 6) Once filling has ended, push the red button to silence the alarm.

- 7) Empty the hose from the delivery vehicle by allowing air to enter the hose at the delivery vehicle end to push the remaining AdBlue ® liquid through to the AdBlue ® container.
- 8) Disconnect the delivery vehicle hose (and adaptor where fitted) from the container filling inlet and replace the filling inlet cover.
- 9) Where applicable, disconnect the truck valve cable from the truck connector in the hydraulic area of the dispenser.
- 10) Refit the hydraulic door and lock ensuring the filler cap ring lies flat before closing the hydraulic door.



5.6.3 LEAK DETECTION SYSTEMS

Once the container has been filled, it is recommended that the system be tested for leaks. This check must be carried out daily and a log sheet completed (refer to AdBlue ® User Manual Supplement). If the Bundman Leak Detection system is not fitted then the container must be visually inspected for leaks.

BUNDMAN LEAK DETECTION

- 1) Locate the Bundman Leak Detector on top of the filling box (Tokheim AdB containers) or on the filling box cover (Customer Specific 1 AdB Containers).
- 2) Push the “Press & Hold” test button.
- 3) Wait for LED to indicate the test result:-



<u>Result</u>	<u>Action</u>
Bund Empty	None
Not Empty	Contact Tokheim immediately. Do NOT use the dispenser. Take precautions to ensure the leak is contained.
Sensor/Battery	Contact Tokheim. Safe to continue to use the dispenser only if the container is visually inspected daily for leaks until the sensor and/or battery have been replaced.



- 4) Refit the hydraulic door and lock ensuring the filler cap ring lies flat before closing hydraulic door.



5.7 Heating Systems

Heating in AdBlue® dispensers is an option. There are three different types of heating:-

- Non-ATEX Heating (refer to section 5.7.1)
- ATEX Electric Heating (refer to section 5.7.2)
- ATEX Water Heating (refer to section 5.7.3)

5.7.1 NON-ATEX HEATING OVERVIEW

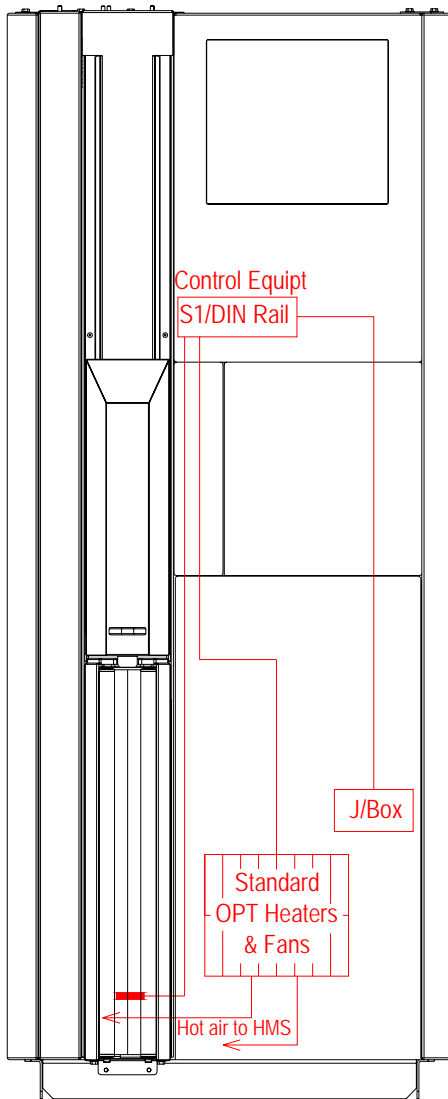

Non-ATEX Heating comprises two standard OPT heaters and fans mounted in the hydraulic area to heat the hydraulics and HMS. Both fan heaters operate together, controlled by capillary thermostat S1 mounted in the calc box with its sensor mounted in the HMS.

When the temperature in the HMS drops to -5°C , thermostat S1 starts the fan which blows hot air from the heater to the HMS. The fan heater operates until the temperature in the HMS rises to $+5^{\circ}\text{C}$, switching on and off as controlled by S1 to maintain the temperature in the HMS above -5°C .

5.7.2 ATEX ELECTRIC HEATING OVERVIEW

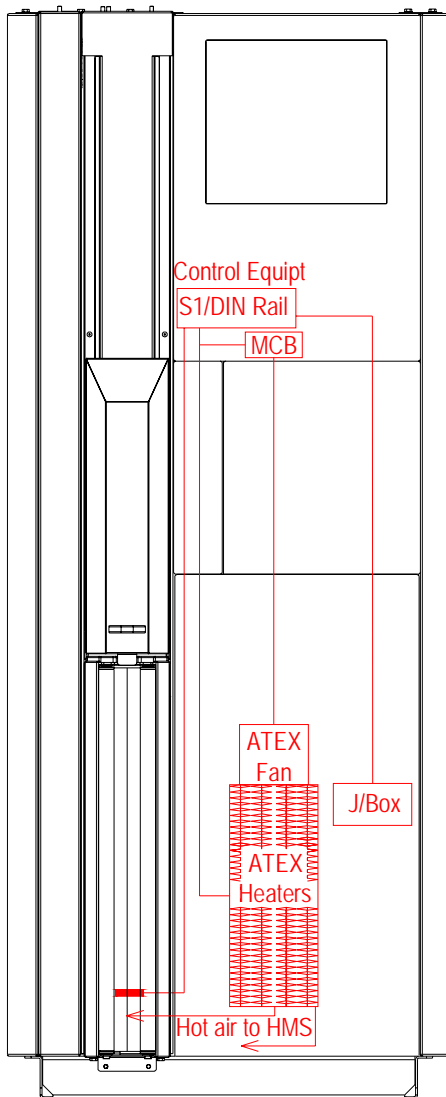

ATEX Electric Heating comprises an EEx e approved fan and two 300W EEx e approved heaters mounted in hydraulic area to heat the HMS and hydraulic area which operate as a conventional fan heater, controlled by capillary thermostat S1 mounted in the calc box with its sensor mounted in the HMS.

When the temperature in the HMS drops to -5°C , thermostat S1 starts the fan which blows hot air from the heater to the HMS and hydraulic areas. The fan operates until the temperature in the HMS rises to $+5^{\circ}\text{C}$, switching on and off as controlled by S1 to maintain the temperature in the HMS above -5°C .

5.7.3 ATEX WATER HEATING OVERVIEW

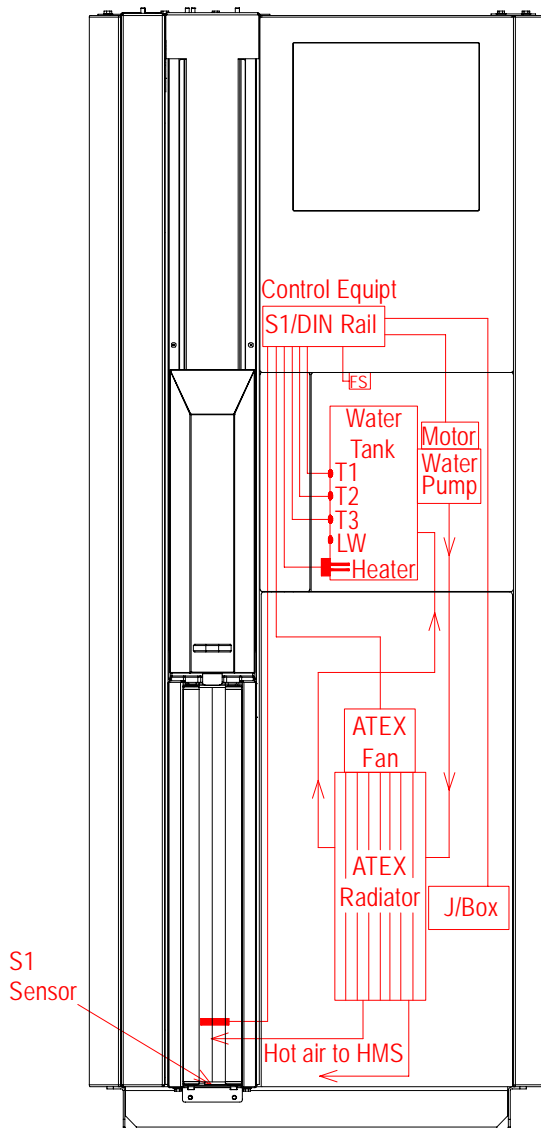

- T1 = Water Tank Thermostat (open 40C; close 25C)
- T2 = Water Tank Thermostat (open 35C; close 50C)
- T3 = Water Tank Thermostat (open 70C; close 55C)
- LW = Low Water Level Switch
- FS = Tank Filling Switch

ATEX Water Heating is a mini central heating system comprising of a tank with water heater and thermostats, circulating pump, radiator, fan and din rail mounted control system.

When the temperature in the HMS drops to -5°C , thermostat S1 starts the internal tank water heater and energises the pump motor (water level must be sufficient and water temperature $<75^{\circ}\text{C}$ to allow S1 to control the water heater). Water is then pumped from the tank to the radiator then back to the tank. The fan remains off until the water temperature rises to $+35^{\circ}\text{C}$ at which point the fan will start to blow hot air from the radiator to the HMS and hydraulic areas.

Control of the heating system is primarily by a capillary thermostat S1 mounted in the calc box with its sensor mounted in the HMS.

Until the ambient temperature of the HMS reaches $+5^{\circ}\text{C}$, the water heater switches on and off to maintain the water temperature at 60°C . When the temperature of the HMS rises above $+5^{\circ}\text{C}$, thermostat S1 shuts down the heating system. The heating system switches on and off as controlled by S1 to maintain the temperature in the HMS above -5°C .

The combined heating system of tank, radiator and pipe assembly has a liquid capacity of 6 ltrs. (approx). It is recommended that a combined protector and anti-freeze is added to the water to avoid any possibility of freezing. Use a locally available leading brand and follow the dilution instructions of the manufacturer.

When the Low Water Level Switch is activated, the system shuts down and the tank needs re-filled. The fill switch must be turned to the fill position so that the normal pump control and safety devices are bypassed to enable the pump to run while the tank is being filled, thus preventing any air locks forming in the system. After filling, the switch must be returned to normal position to transfer control of the pump back to thermostat S1.

5.7.4 FILLING AND PRIMING THE WATER HEATING SYSTEM

To gain access to the water tank for filling, unscrew the 4 wing nuts located on the top of the lid. Remove them and place in a secure location. Remove the lid.

There are no electronic components mounted on 'side B' of the dispenser, therefore filling of the system should be undertaken with access through the DIT box door.

The system should be filled so that the water level is approximately 10-15mm from the lip of the tank. Check all pipe work carefully for any signs of leakage, any drips or seepages must be rectified immediately.

The system should then be primed to eradicate any air from the system. A 230V AC electrical supply must be supplied to the dispenser at this stage in order for the pump to operate. The pump is controlled by switching the manual over-ride switch (located on the roof of the DIT box on 'side B' of the dispenser) from auto mode to manual. The operation of the pump will be identified by noise from its electric motor and slight bubbling from within the tank as any air is expelled to atmosphere. The pump should need run for no longer than 30 seconds. If during this time the water level within the tank drops to more than 30mm from the tank lip switch the manual over-ride switch over to auto and proceed to fill the tank back up to 10-15mm from the lip. Repeat this until there is no more bubbling from the tank, and no further drops in the water level are detected over a 30 second period.

The tank lid should now be reattached and the wing nuts fastened. Make one last inspection for any water escaping from the system.



5.8 Electrical Connections - General



During installation, the main switch must be switched off - ensure the main switch cannot be switched on inadvertently.

The installation of the cables must be carried out carefully to ensure the Exd rating of the junction box is maintained (insertion of cables via glands).

The electrical connections are compatible with all European installation practices and typical country specific cable types.

The maximum number of forecourt cables required will be:-

- One power cable for calculator(s)
- One power cable for lighting supply
- One power cable for heaters (heating option only) & pump motor (container models only)
- One/two cable(s) for dispenser communications
- One cable for speaker (optional)
- One cable per side for OPTimum communications (optional)
- One cable per submerged pump control signal
- One cable for sliding door alarm and/or temperature too low alarm (optional)

HEATING (OPTIONAL)

Where fitted, the heaters will be controlled from separate circuit breakers and labelled with a warning sticker stating the **heaters should not be turned off except in the event of an emergency or during maintenance procedures**. Heater operation must be tested by the use of a freeze spray on the thermostat contacts - refer to section 6.

CABLING

The type of cabling used will differ by country according to local and/or national laws and regulations. The drawings in this section show the minimum number of cores required in cables and the minimum core cross sectional area. Cables with more than the minimum can be used provided that the cables are suitable for use with the cable gland sizes fitted. Individual cables can be combined provided that the minimum number of conductors remains.

ELECTRONICS AND LIGHTING PROTECTION

Tokheim recommends the use of a 2-pole thermal-magnetic device for the protection of the metering pump electronics. A fuse must **NOT** be used in the neutral conductor. Thermal-magnetic Breakers or fuses must be capable of extinguishing a fault current of at least 4000A. Dispenser lighting and remote lighting switches are options.

5.8.1 MAIN M2000 JUNCTION BOX WIRING

During the removal or replacement of the M2000 Junction Box cover, the machined flame path of the cover and the junction box should be inspected for damage. If any defects or scratches are found then the junction box and/or cover must be replaced - this is essential for product safety. Once removed, always store the cover in a safe place.

Note : The correct tightening torque for the junction box cover is 18Nm.

Three different sizes of cable gland entries are available from Tokheim for the M2000 Junction Box:-

- For cable sizes 8-11mm
- For cables sizes 10-13mm
- For cable sizes 14-17mm

Ensure that the correct gland size is chosen to suit each installation cable. Failure to do so will compromise product safety.

The special requirements relating to the use of the M2000 Junction box are:-

- All glands must be tightened to a torque of 35Nm.
- Ensure that all cables terminating in the M2000 Junction Box are securely fastened to the dispenser frame adjacent to the box.

The wiring in the main junction box will vary according to different models and options. The drawings in this section show the Tokheim recommended installation but differences may exist in the standards relating to installation in different countries and local regions, in which case the local and/or national standards must be employed.

- For the purpose of insulation resistance testing and service activities, the mains fuses on the din rail within the calculator housing act as the disconnection device.

5.9 AdB Standalone & AdB Container Dispensers

Use the main M2000 Junction Box located on side B of the dispenser for all power, lighting, calculator, heating (optional) and sub pump cables, AdBlue ® Comms and optional DIT Comms. Use additional Bernstein Junction Boxes for Audio and/or Fire and Tilt Detection options.

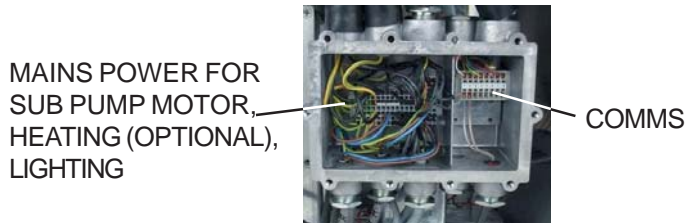

5.9.1 POSITION OF JUNCTION BOXES IN ADB DISPENSERS

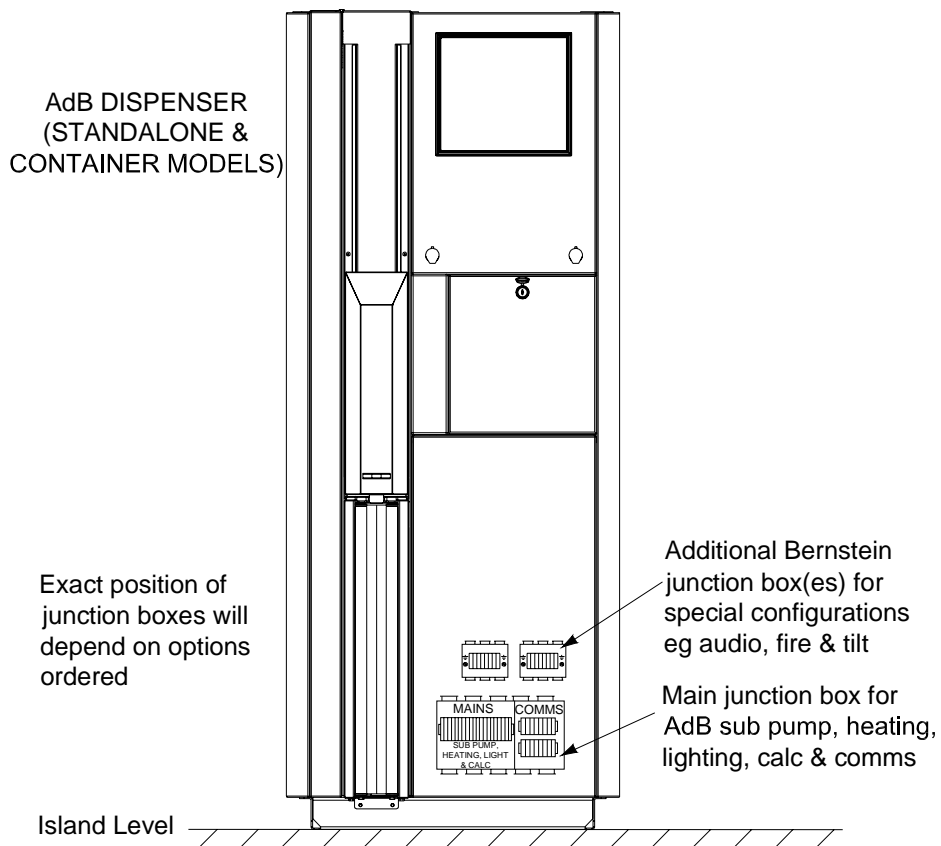

5.9.2 NO HEATING & NON-ATEX HEATING

WIRING OVERVIEW

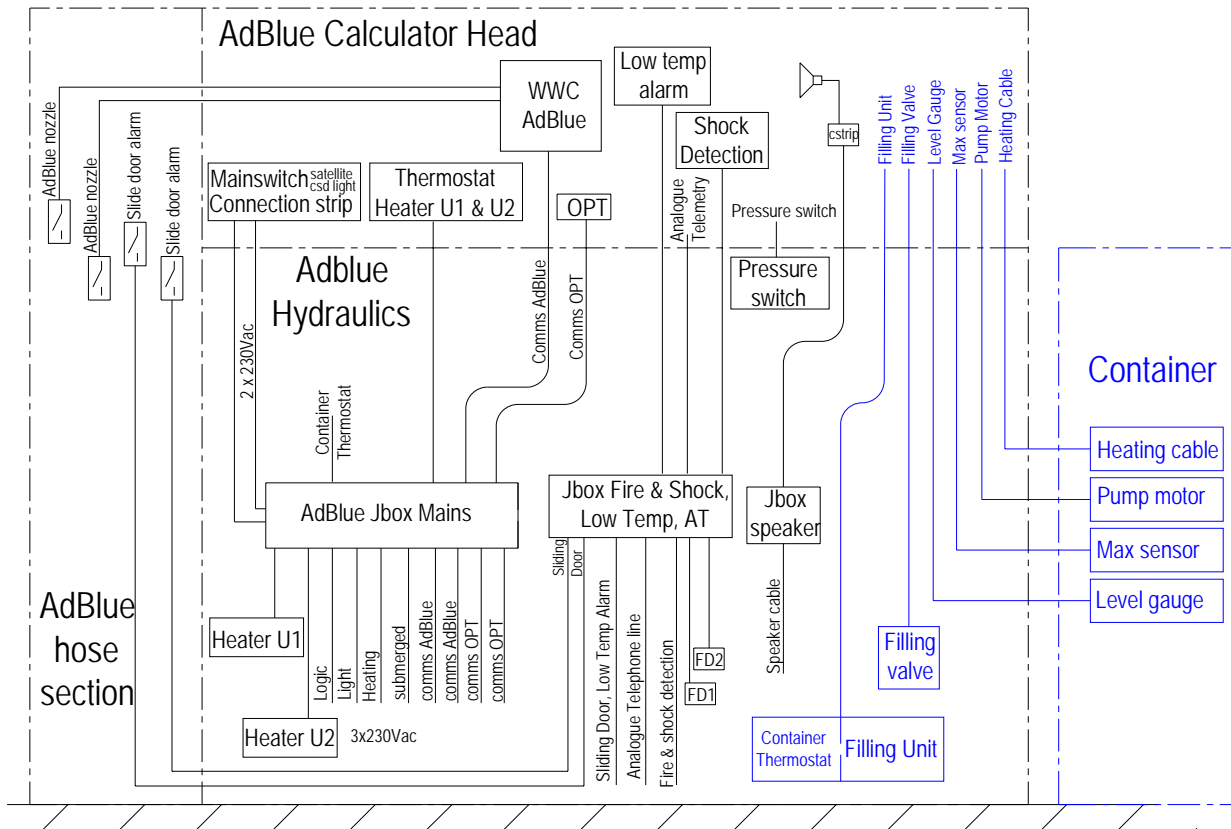

ADB STANDALONE MODELS - VERSIONS 1,2,3

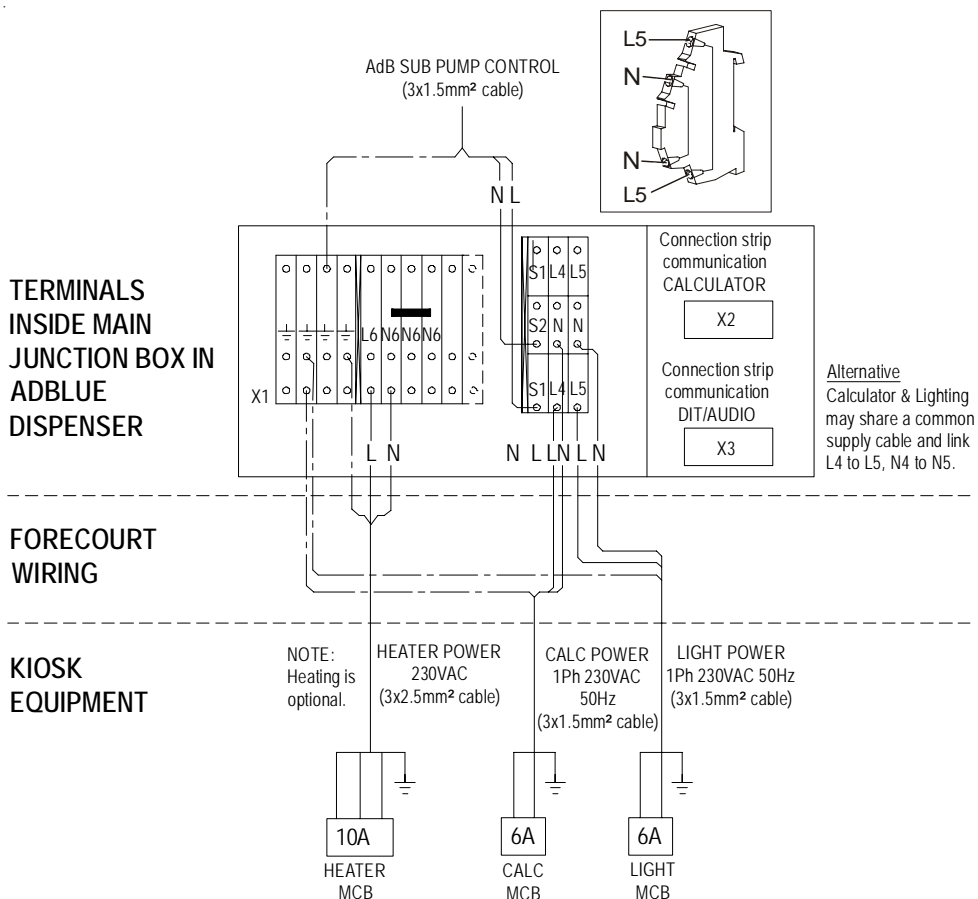

ADB & CONTAINER MODELS - VERSION 1

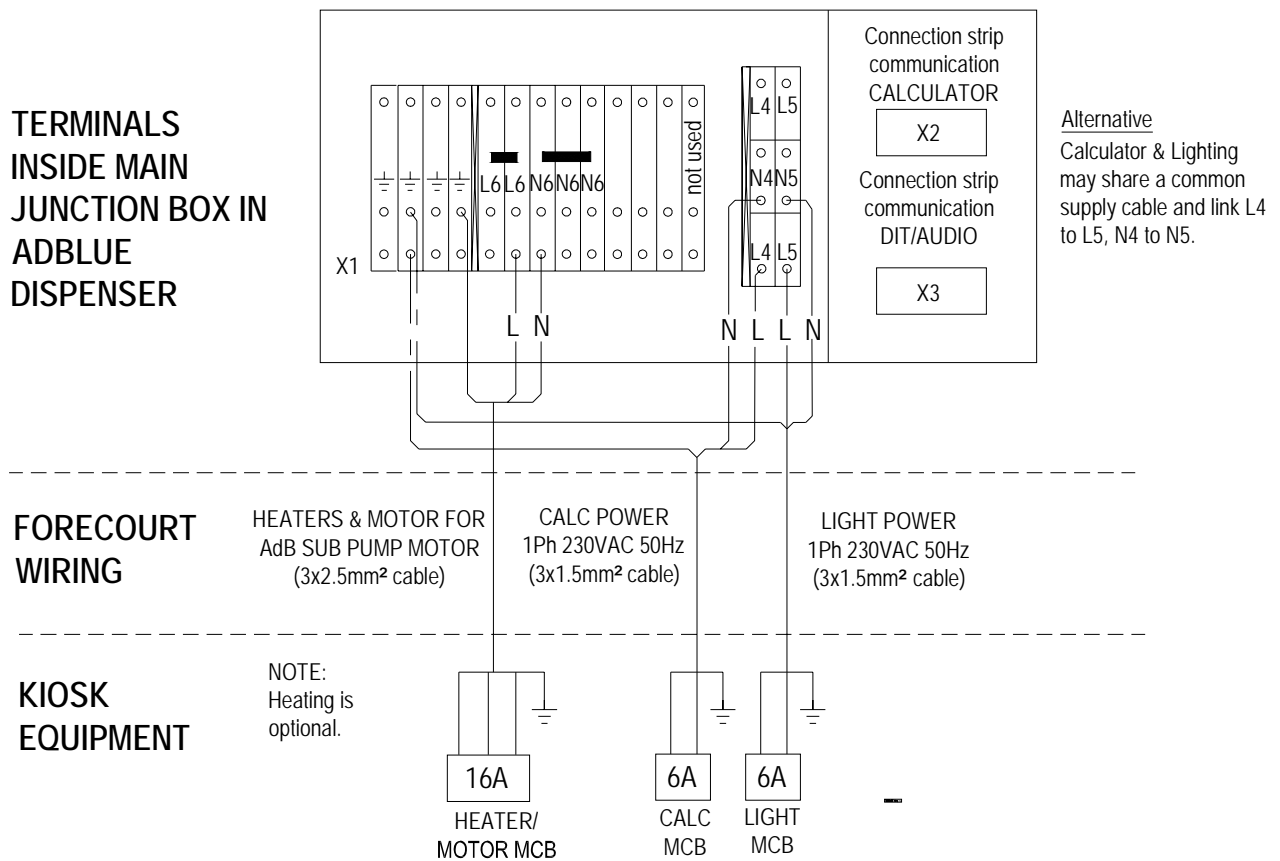

ADB & CONTAINER MODELS - VERSIONS 2 & 3

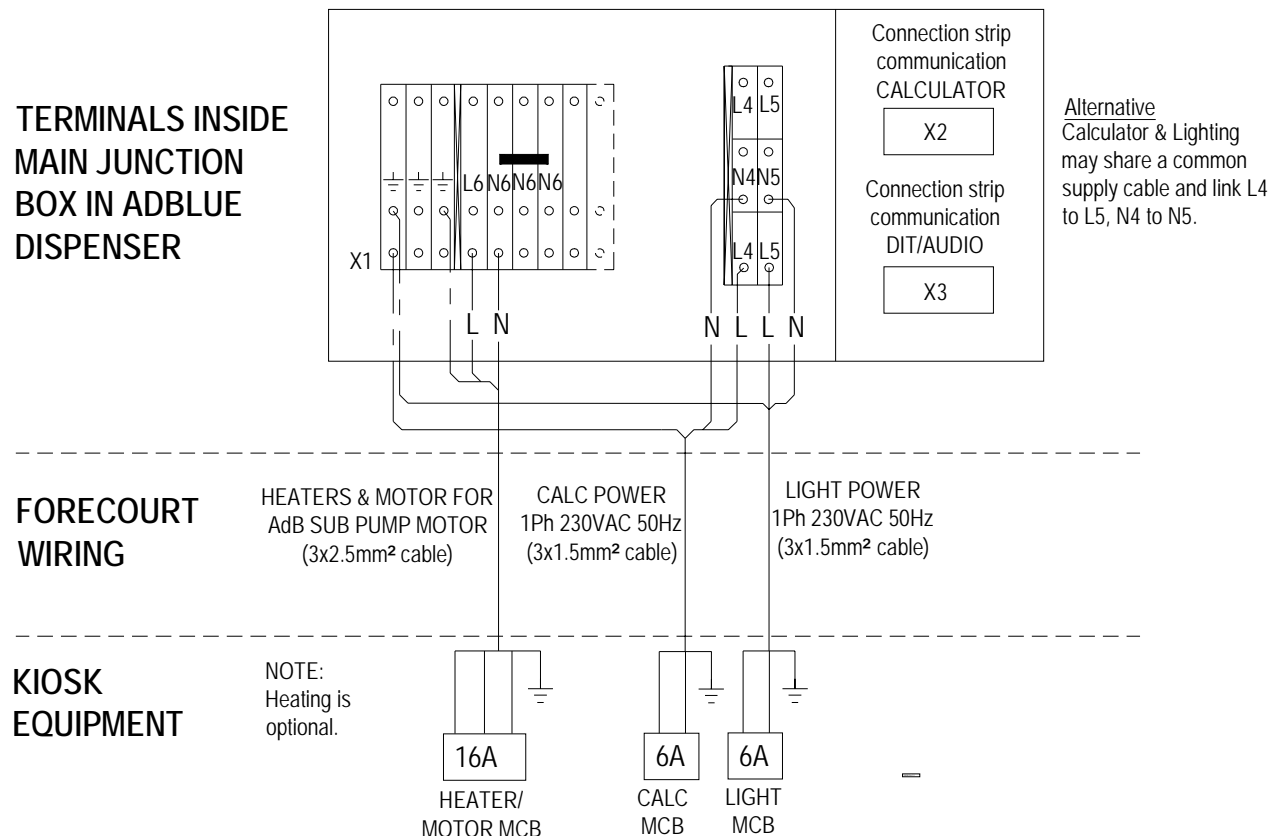

5.9.3 ATEX ELECTRIC HEATING

MAIN JUNCTION BOX IN ADBLUE DISPENSER

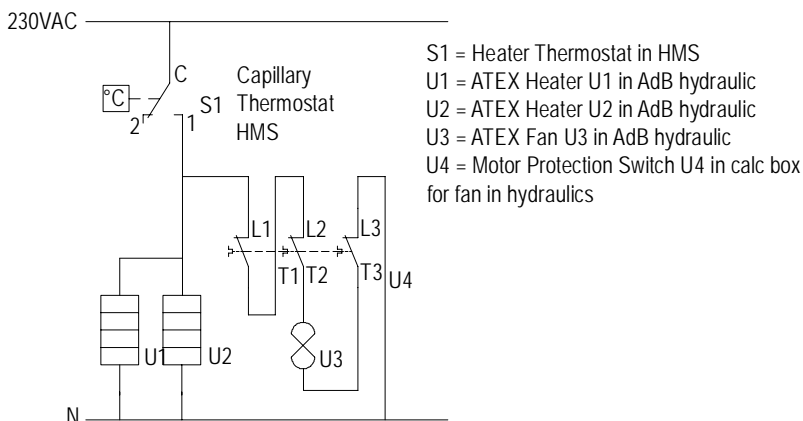
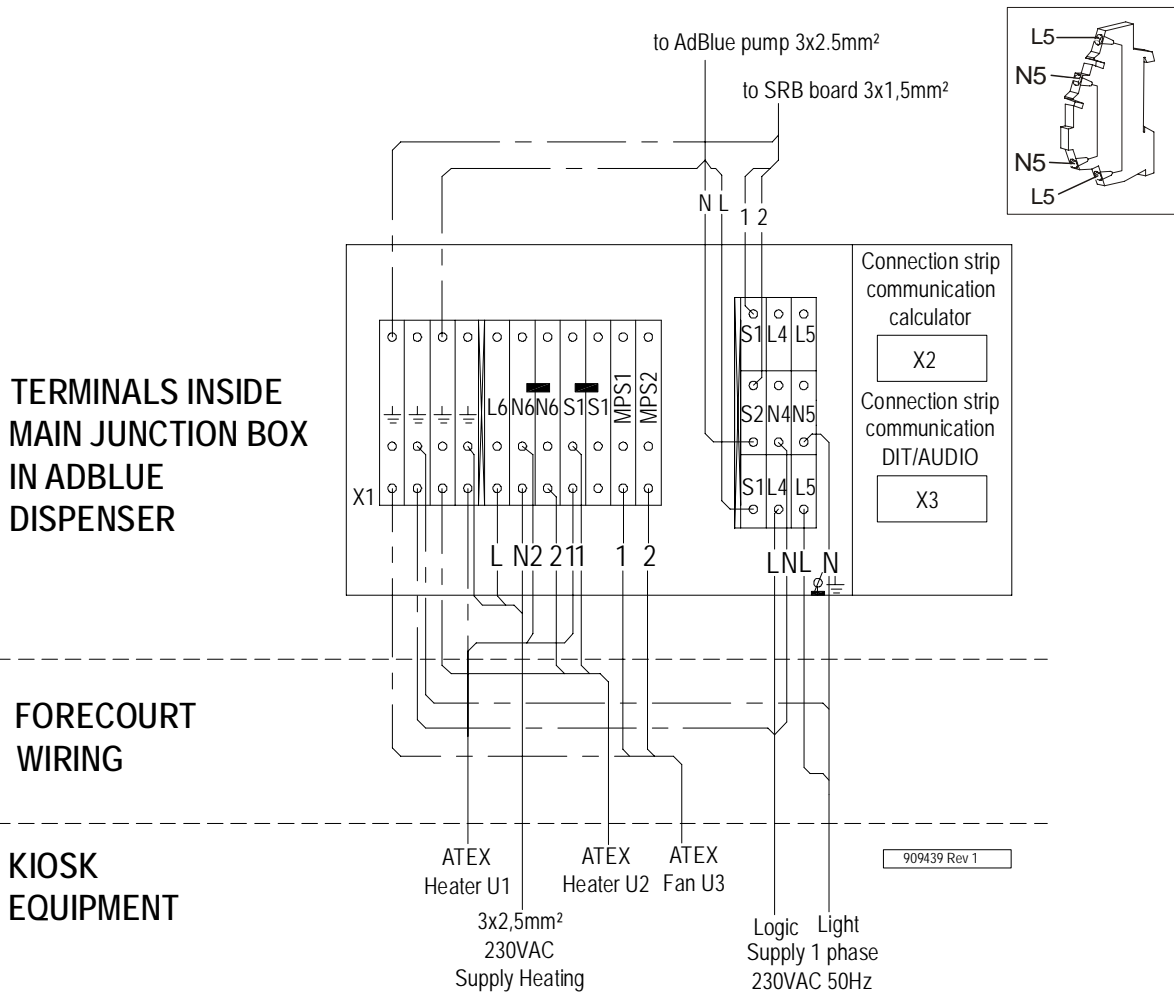

5.9.4 ATEX WATER HEATING

MAIN JUNCTION BOX IN ADBLUE DISPENSER

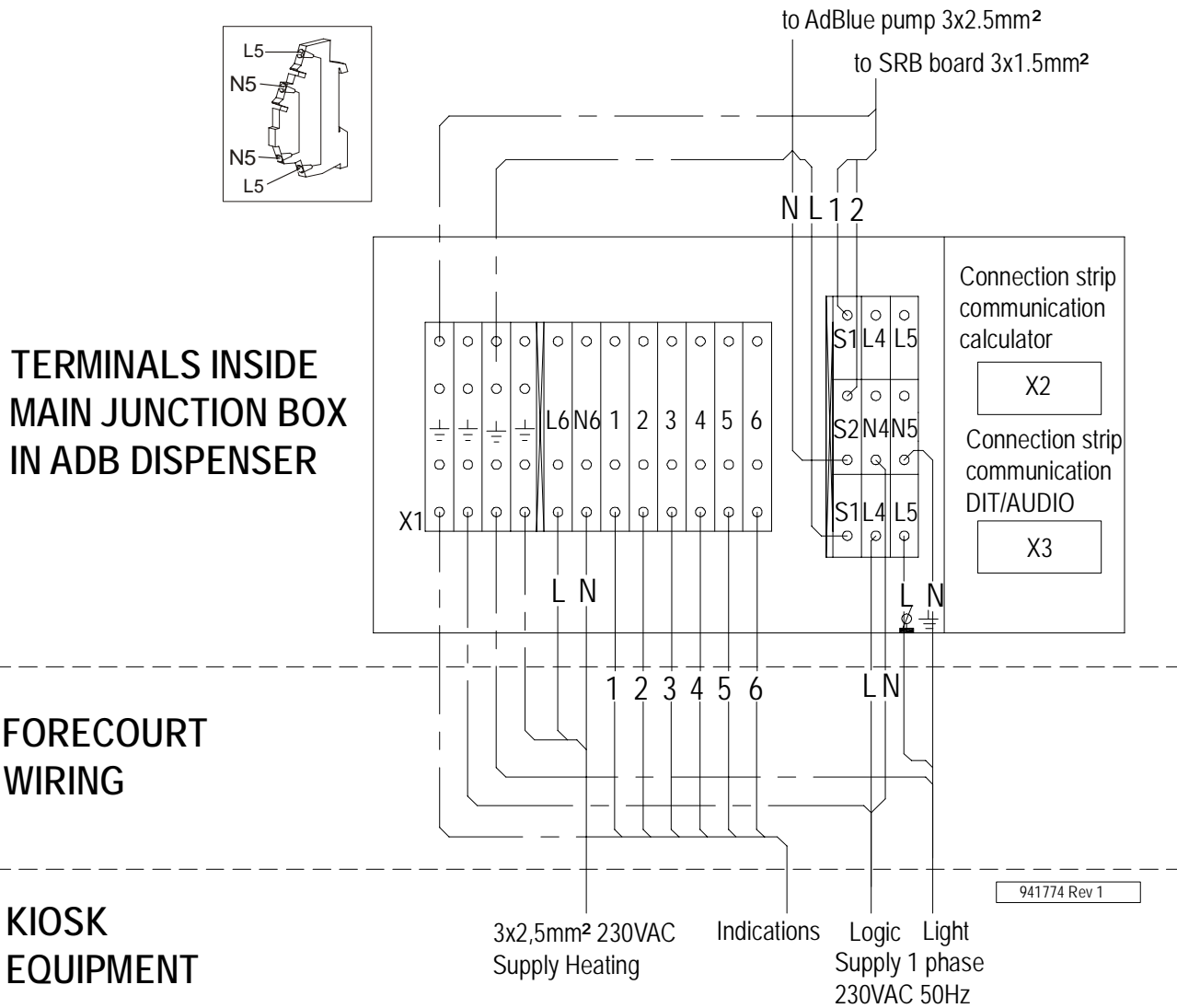

5.10 AdB dispensers

AdBlue ® CP dispensers do not have a calculator and must be connected as an additional product to a host dispenser using the calculator and display of the host dispenser. Refer also to relevant dispenser Installation, Maintenance and Parts Manuals as appropriate for electrical connections relating to the host dispenser.

The AdBlue ® CP and Mini Combo dispensers are fully wired in the factory with all connections from the mains heating, pulsers, nozzles and valves terminated in a Tokheim M2000 Junction Box.

Note : The M2000 Junction Box is rotated 180° in order to locate the smaller compartment used for the mains wiring to the left hand side of the junction box (the normal side used for mains wiring). The larger section is required for the signal wiring to the valves, pulsers and nozzles.

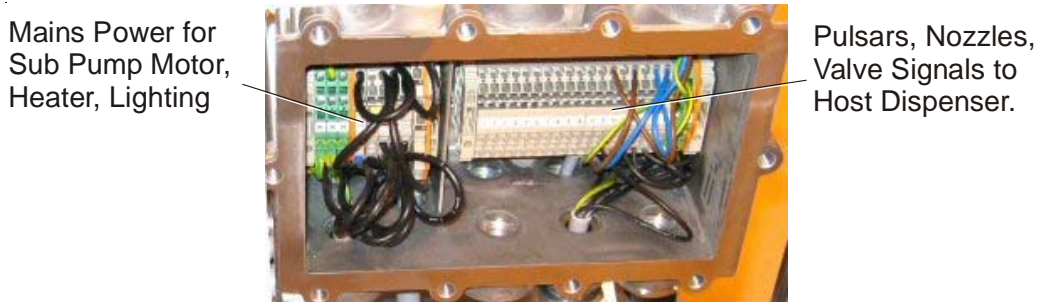

FORECOURT CABLING

All cables between the AdB CP dispenser and the host dispenser must be routed safely and in accordance with local and/or national regulations relating to forecourts. Tokheim recommends the use of a plastic underground cable duct to route the cables between AdB CP and host dispenser.

HOST DISPENSER RETROFIT

A Bernstein CA170 Junction Box and suitable mounting bracket are fitted to a suitable position in the host dispenser (exact position and bracketry will depend on the model of the host dispenser).

The pulser, valve and nozzle cables are fed through a cable duct from the AdB CP dispenser into the new Bernstein Junction Box in the host dispenser. The cables are then routed through convenient glands to the calculator head in the hose dispenser. For certain models, for example retrofitting the AdB CP to a Q500T1 VHS1-1 host dispenser, it may be necessary to add a HOM board to the host dispenser and move the pulser and valve wiring from the mainboard to the HOM board then move the connections for the nozzle switch from the nozzle connectors on the mainboard to a cable assembly connected fitted to X105 normally used for a ribbon cable to the I/O board.



5.10.1 POSITION OF JUNCTION BOXES IN ADB CP & HOST DISPENSERS

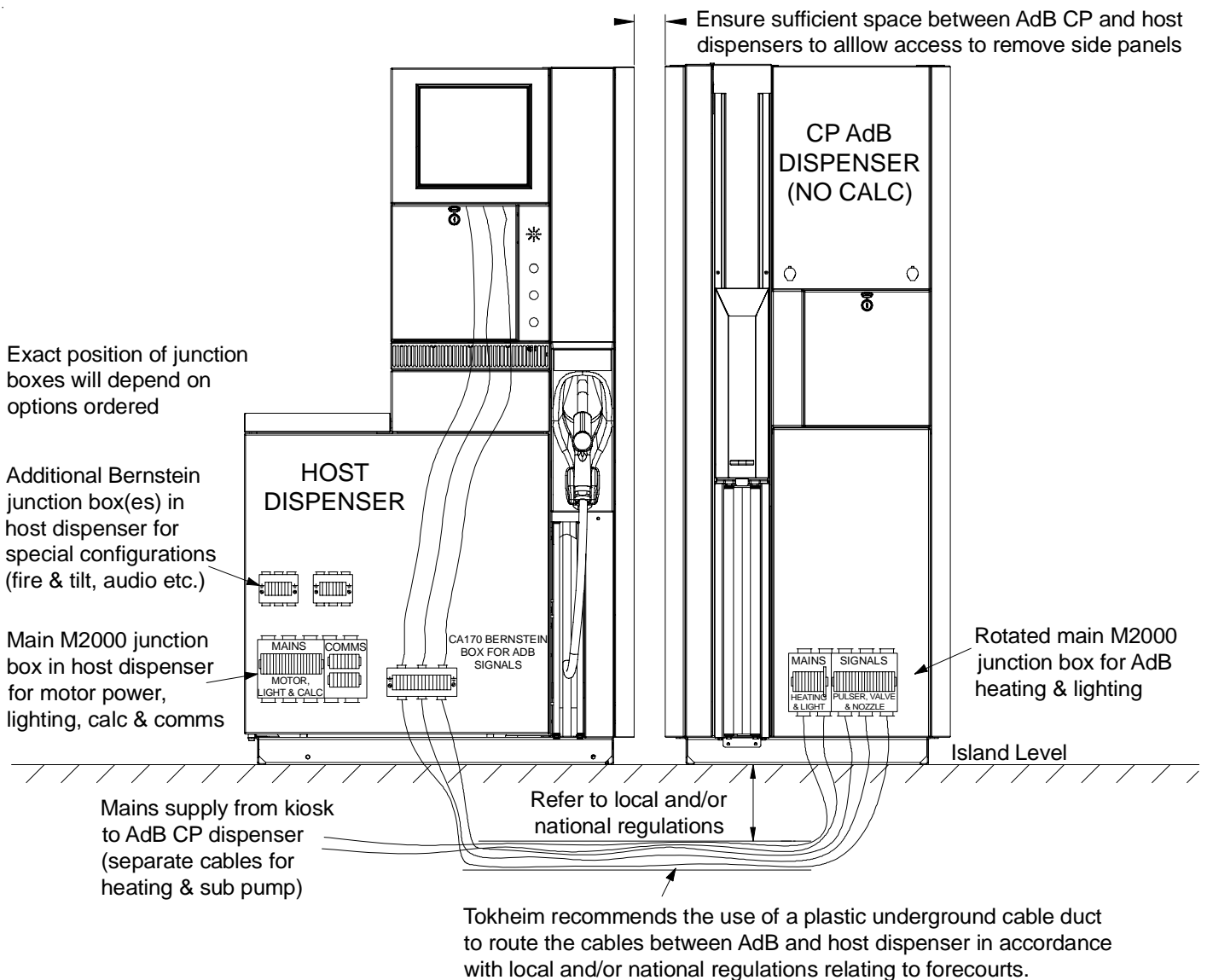

5.10.2 NO HEATING & NON-ATEX HEATING

WIRING OVERVIEW

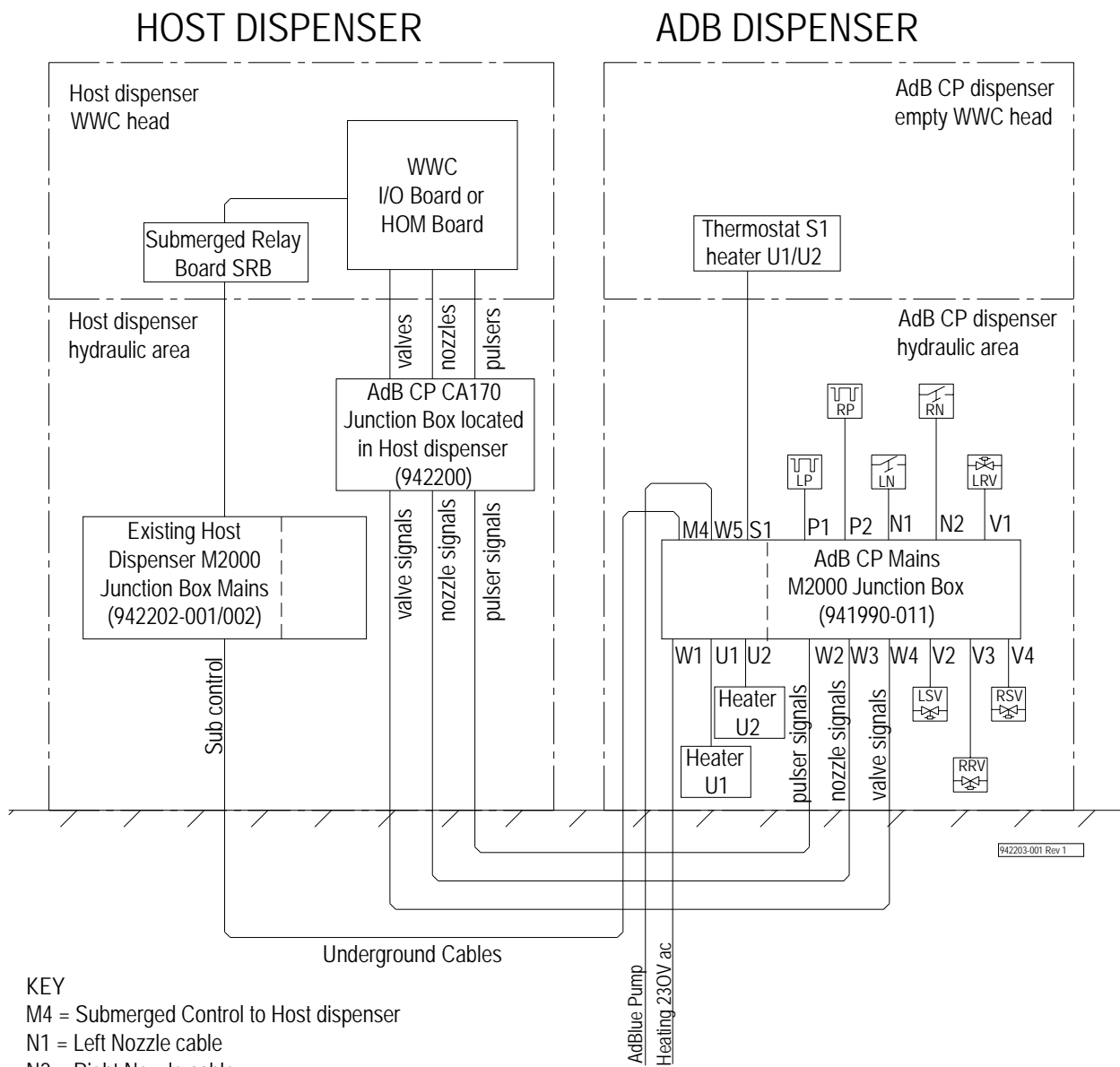

MAIN JUNCTION BOX IN ADB CP DISPENSER

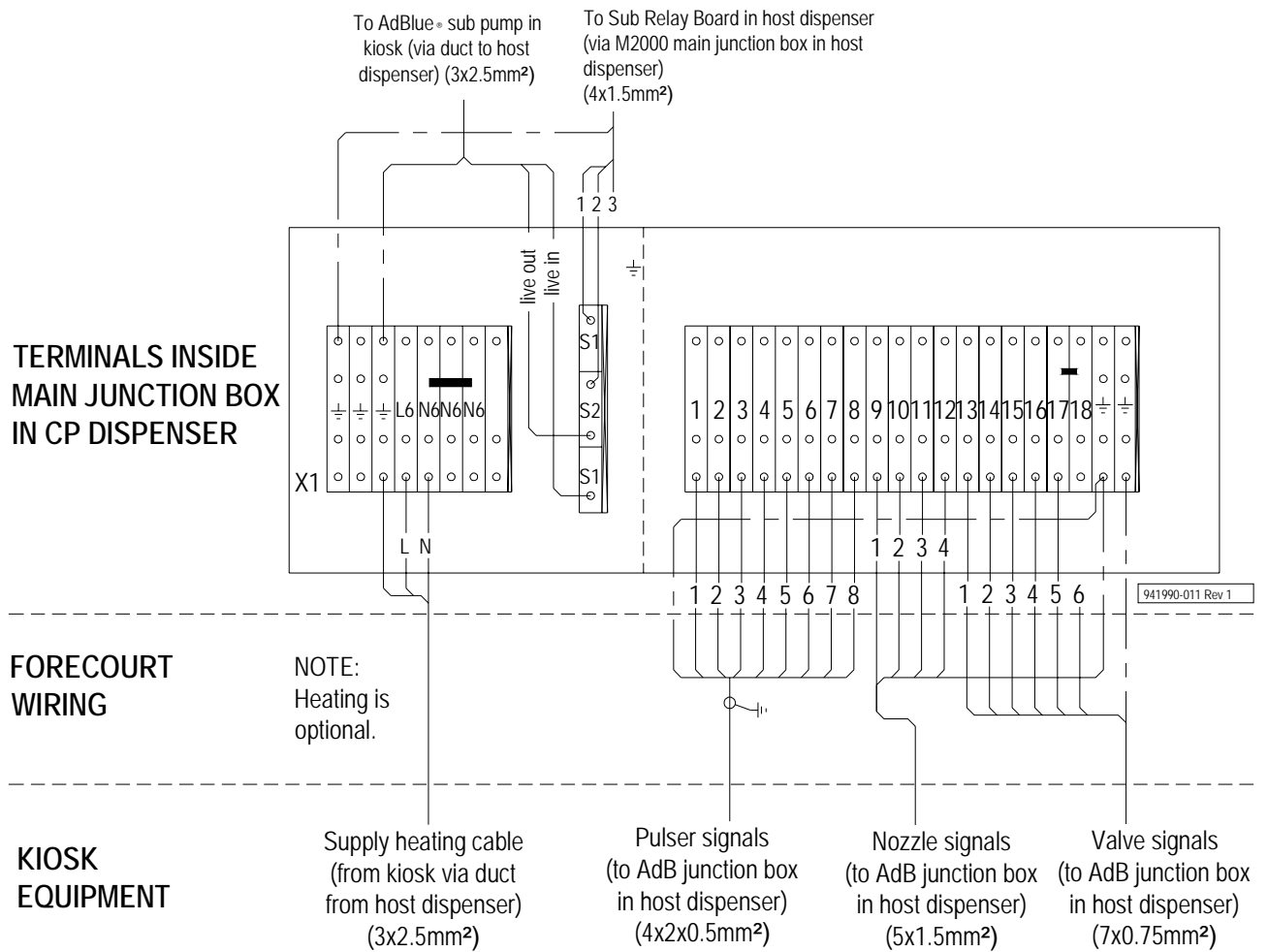

GLAND ALLOCATION QT ADBLUE

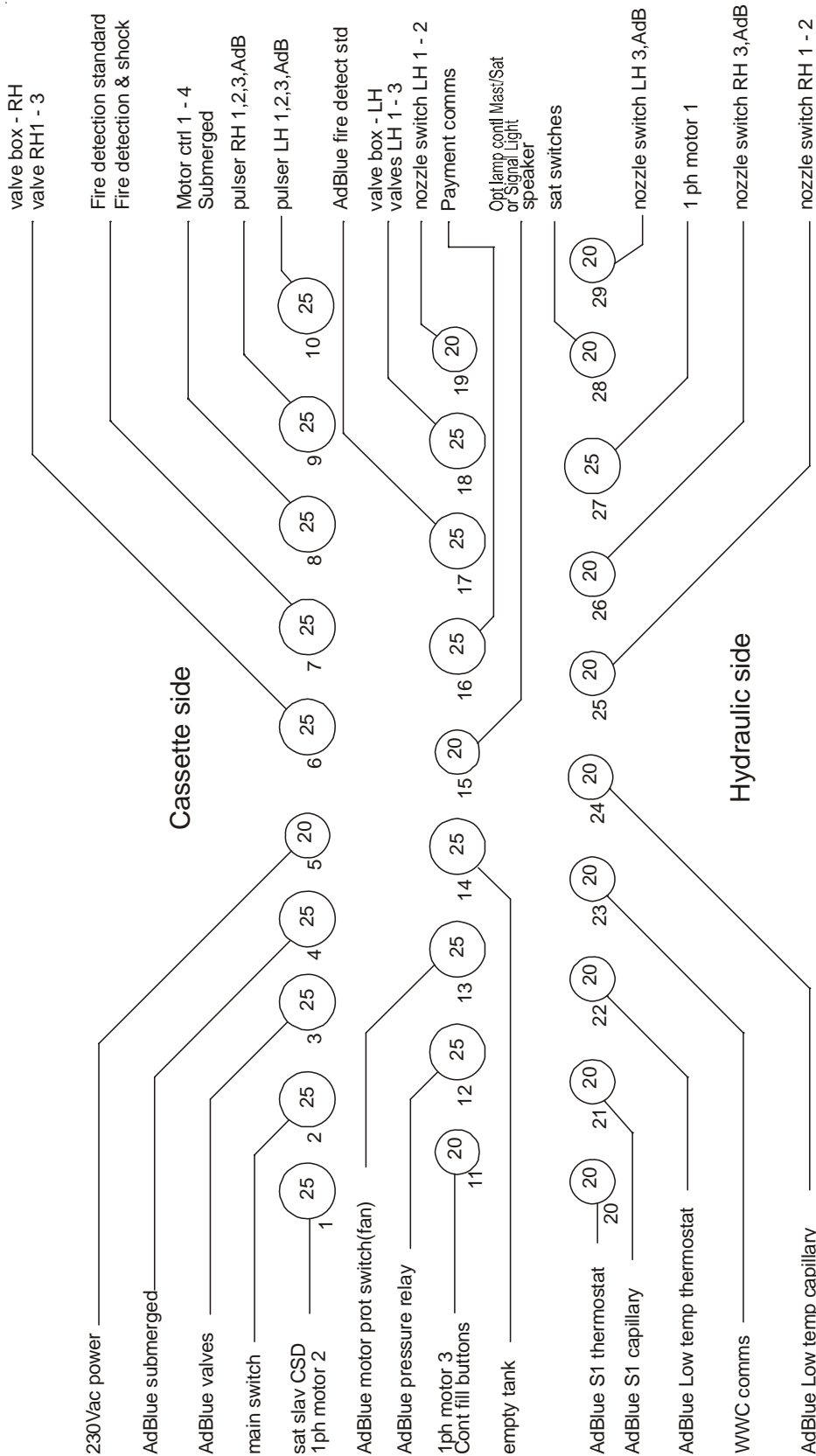

0.0572-08

MAIN JUNCTION BOX IN HOST DISPENSER - SUCTION ONLY

HOST DISPENSER MODEL	VHS1-1*, VHS1-2	VHS2-4	VHS3-6
AdB CP	I/O BOARD CONNECTION ON MASTER DISPENSER		
SRB	X108 - M1	X108 - M1	X108 - M2

Table Notes

- 1) SRB is located in Host dispenser.
- 2) * means I/O Board required to be fitted as part of retrofit in Host dispenser.
- 3) SRB required to be fitted as part of retrofit in Host dispenser.
- 4) VHS1-1 Host dispensers will require a HOM1 Board; Host dispenser for product 1 is required to be wired to Hydraulic Set Up 52.
- 5) Additional terminals required in existing Host dispenser Junction Box Mains for SRB.

SUB RELAY BOARD IN HOST DISPENSER (SUCTION DISPENSERS ONLY)

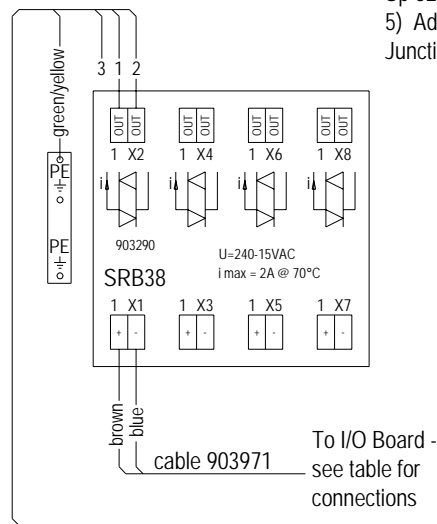

TERMINALS INSIDE MAIN JUNCTION BOX IN HOST DISPENSER (SUCTION DISPENSERS ONLY)

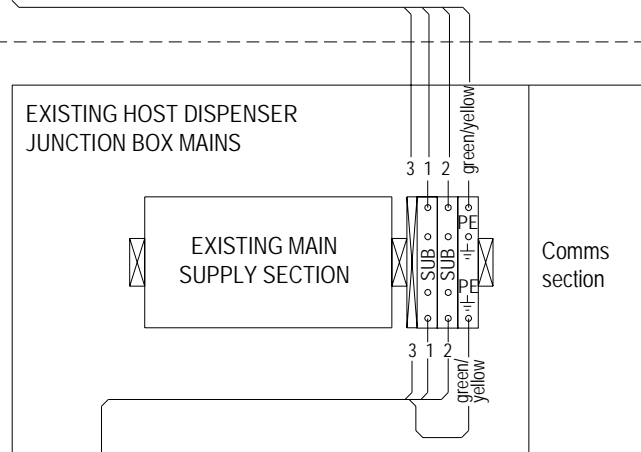

FORECOURT WIRING

FROM ADB CP JUNCTION BOX MAINS

942202-001 Rev 1

MAIN JUNCTION BOX IN HOST DISPENSER - SUBMERGED ONLY

HOST DISPENSER MODEL	VHS1-1*, VHS1-2	VHS1-2ss, VHS2-4	VHS3-6
AdB CP	I/O BOARD CONNECTION ON MASTER DISPENSER		
SRB	X108 - M1	X108 - M1	X108 - M2

Table Notes

- Existing SRB is located in Host dispenser.
- * means I/O Board required to be fitted as part of retrofit in Host dispenser.
- VHS1-1 Host dispensers will require a HOM1 Board; Host dispenser for product 1 is required to be wired to Hydraulic Set Up 52.
- Additional terminals required in existing Host dispenser Junction Box Mains for AdBlue sub pump.

SUB RELAY BOARD IN IN HOST DISPENSER (SUBMERGED DISPENSERS ONLY)

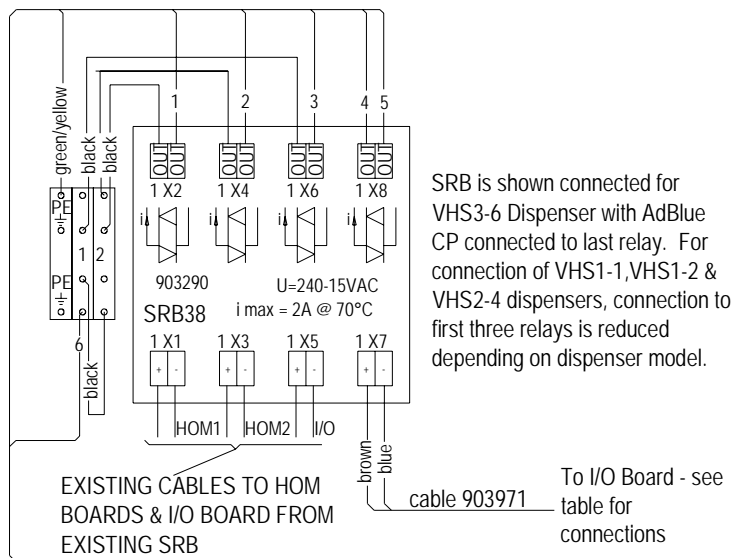

TERMINALS INSIDE MAIN JUNCTION BOX IN HOST DISPENSER (SUBMERGED DISPENSERS ONLY)

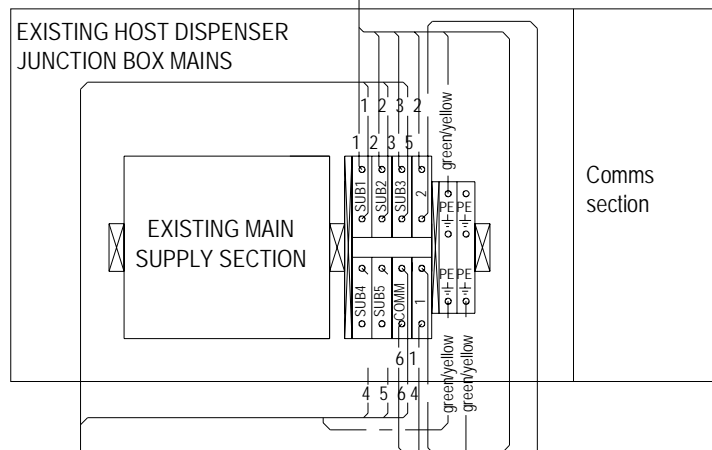

FORECOURT WIRING

EXISTING SUBMERGED CABLE

3 M4 FROM ADB CP JUNCTION BOX MAINS

942202-002 Rev 1

ADDITIONAL BERNSTEIN JUNCTION BOX IN HOST DISPENSER FOR ADB CONNECTIONS

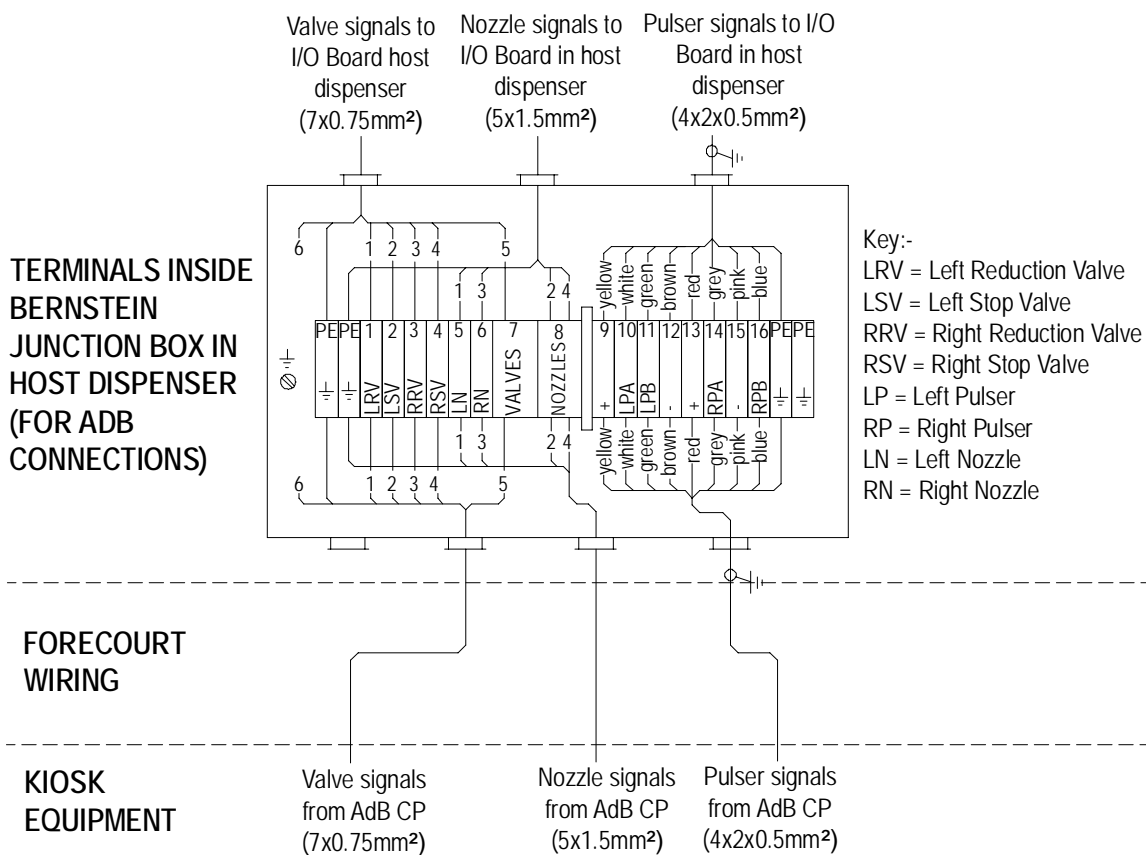
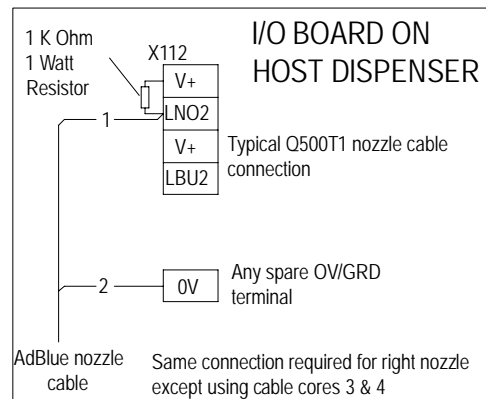

Notes:-

- 1) LP, RP, LN, RN, LRV, LSV, RRV & RSV are all on AdB CP dispenser.
- 2) * means I/O Board required to be fitted as part of retrofit in host dispenser.
- 3) LSV & RSV only connected if host dispenser has preset option.
- 4) For single sided dispensers, only connect left or right pulsers, nozzles & valves as required to match host dispenser.
- 5) Single sided dispensers (left or right sided) are always wired as right sided dispenser.
- 6) VHS1-1 and VHSM1-1 host dispensers will require a HOM1 Board; Host dispenser for product 1 is required to be wired to Hydraulic Set Up 52.
- 7) For Q500T1 dispenser nozzle cable connection, see typical sketch as shown.

HOST DISPENSER MODEL	VHS1-1*, VHS1-2	VHS2-4	VHS3-6
AdB CP	I/O BOARD CONNECTION ON HOST DISPENSER		
LP	X118 - LP1	X118 - LP1	X120 - LP2
RP	X119 - RP1	X119 - RP1	X121 - RP2
LN	X114 - LNO3	X116 - LNO4	X126 - LNO5
RN	X115 - RNO3	X117 - RNO4	X127 - RNO5
LRV	X100 - LRV1	X100 - LRV1	X102 - LRV2
LSV	X100 - LSV1	X100 - LSV1	X102 - LSV2
RRV	X101 - RRV1	X101 - RRV1	X103 - RRV2
RSV	X101 - RSV1	X101 - RSV1	X103 - RSV2

5.10.3 ATEX ELECTRIC HEATING

WIRING OVERVIEW

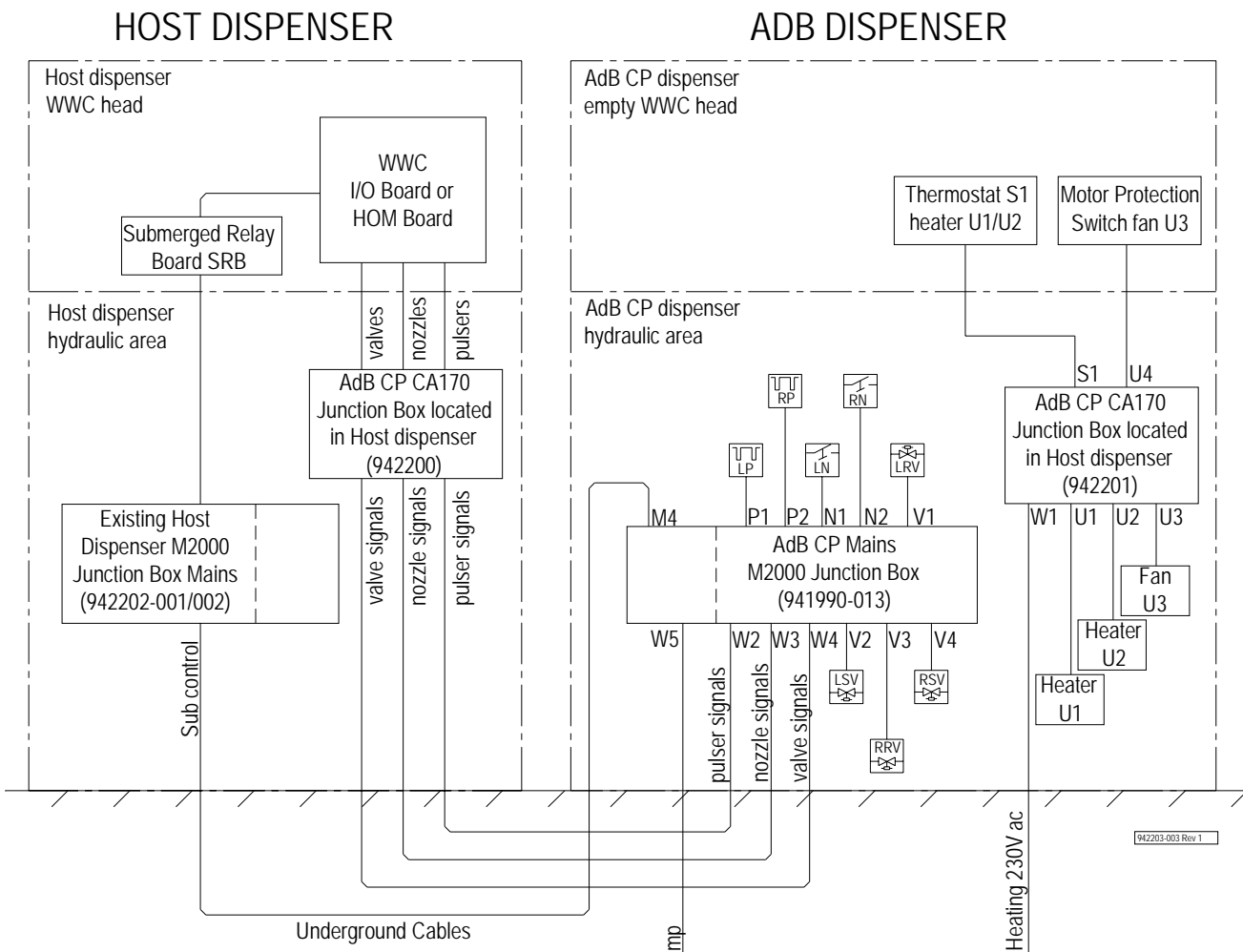

KEY

- M4 = Submerged Control to Host dispenser
- N1 = Left Nozzle cable
- N2 = Right Nozzle cable
- P1 = Left Pulser cable
- P2 = Right Pulser cable
- S1 = Heater Thermostat cable
- U1 = ATEX Heater U1
- U2 = ATEX Heater U2
- U3 = ATEX Fan U3
- U4 = Motor Protection Switch U4 (AdB CP Calc Box for fan U3 in hydraulics)
- V1 = Left Reduction Valve cable
- V2 = Left Stop Valve cable
- V3 = Right Reduction Valve cable
- V4 = Right Stop Valve cable
- W1 = Power cable in (from kiosk via duct in Host dispenser)
- W2,W3,W4 = Pulsers, Valves & Nozzles cables (from AdB CP to Host dispenser)
- W5 = Submerged Pump Control

MAIN JUNCTION BOX IN ADB CP DISPENSER

To Sub Relay Board in host dispenser
(via M2000 main junction box in host
dispenser) (4x1.5mm²)

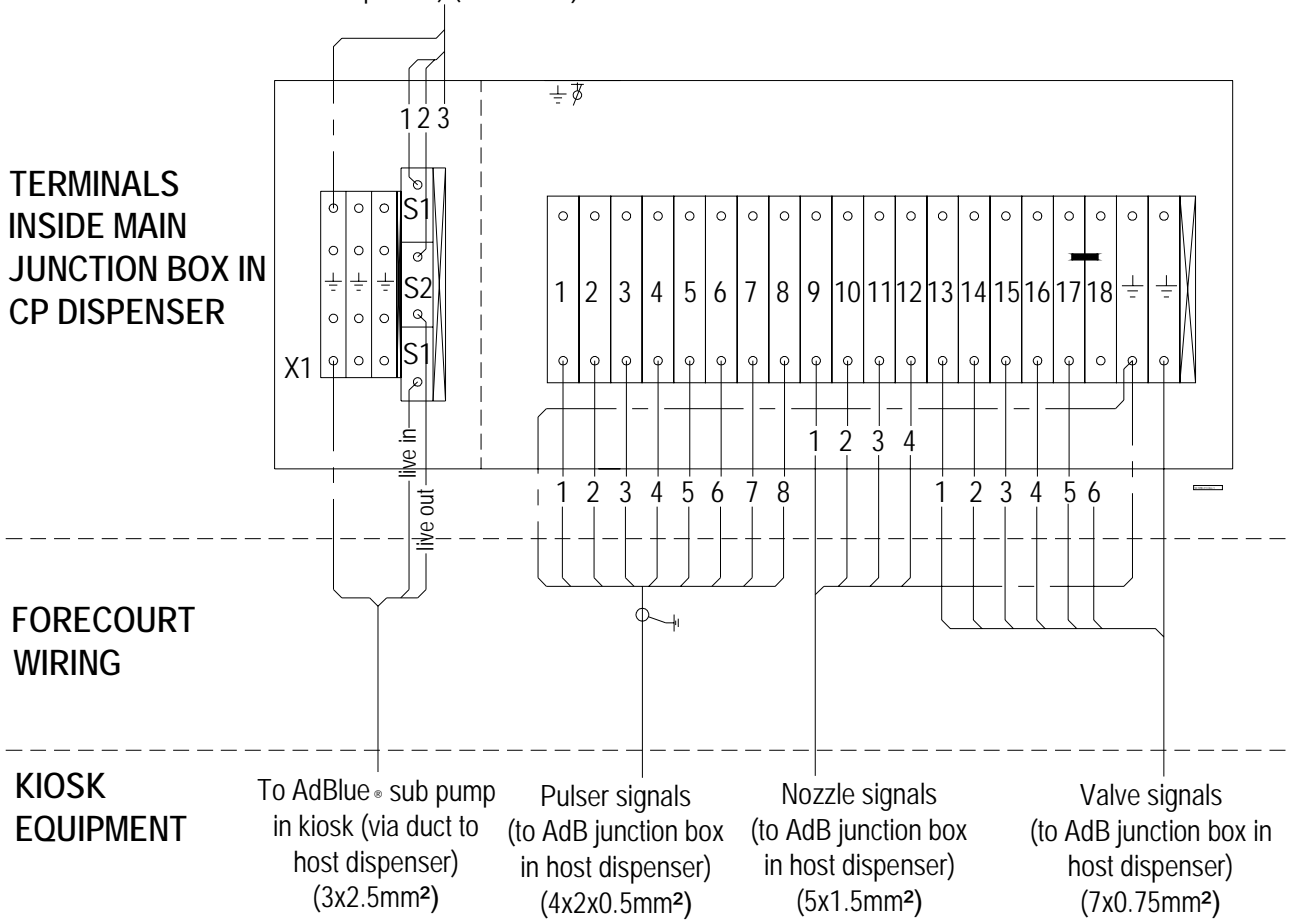

ADDITIONAL BERNSTEIN JUNCTION BOX IN ADB CP DISPENSER

TERMINALS INSIDE
ADDITIONAL BERNSTEIN
JUNCTION BOX IN ADB
CP DISPENSER

FORECOURT
WIRING

KIOSK
EQUIPMENT

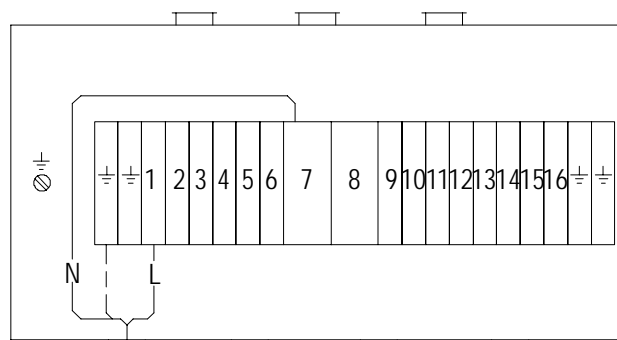

Supply heating cable (3x2.5mm²)

SP-01 Rev 1

5.10.4 ATEX WATER HEATING

WIRING OVERVIEW

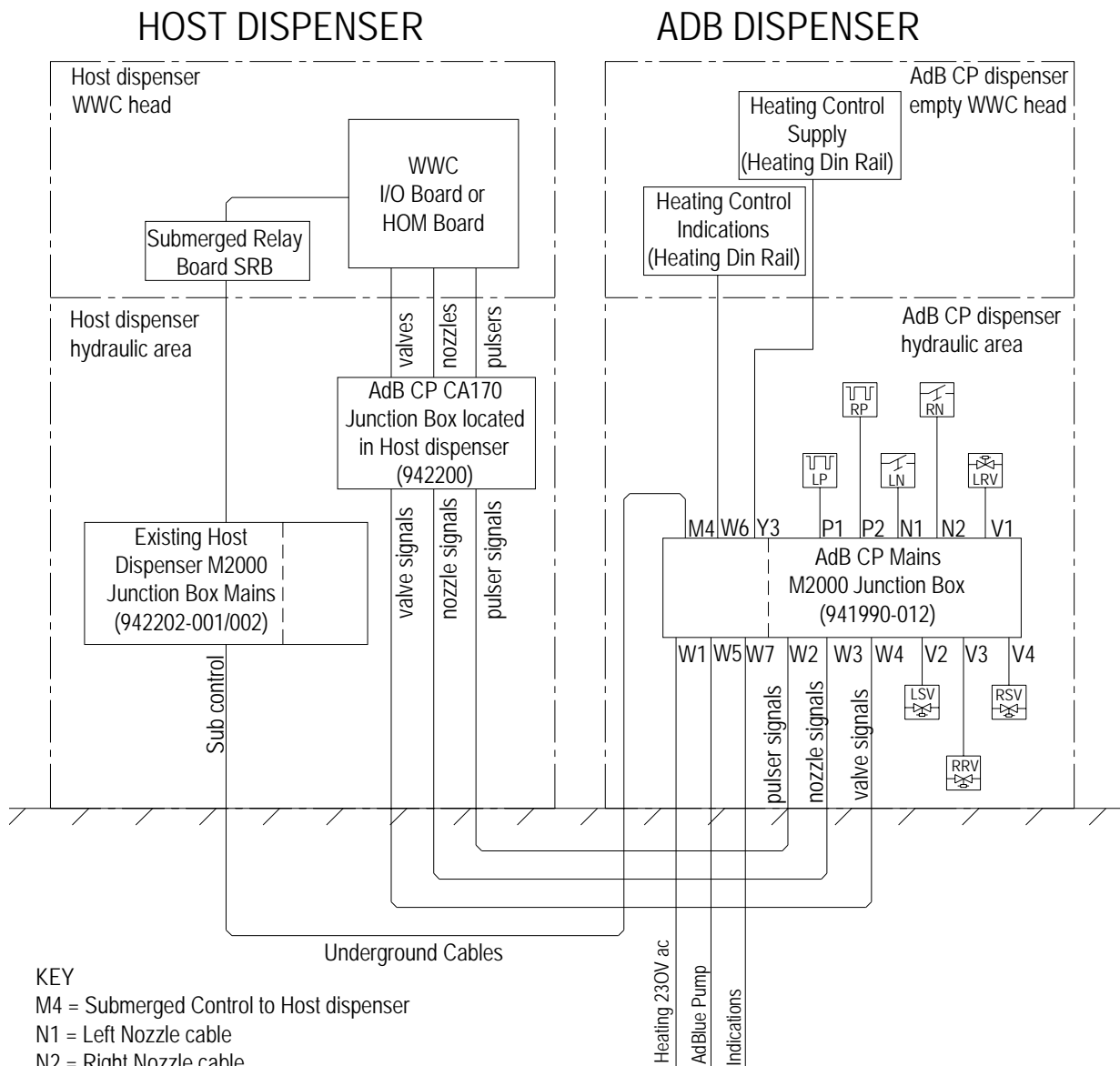

- KEY
- M4 = Submerged Control to Host dispenser
 - N1 = Left Nozzle cable
 - N2 = Right Nozzle cable
 - P1 = Left Pulser cable
 - P2 = Right Pulser cable
 - S1 = Heater Thermostat cable
 - V1 = Left Reduction Valve cable
 - V2 = Left Stop Valve cable
 - V3 = Right Reduction Valve cable
 - V4 = Right Stop Valve cable
 - W1 = Power cable in (from kiosk via duct in Host dispenser)
 - W2,W3,W4 = Pulsers,Valves & Nozzles cables (from AdB CP to Host dispenser)
 - W5 = Submerged Pump Control
 - W6 = Heating Control Indications - low level/low temp/high temp (from rail in Calc Box)
 - W7 = Indications to kiosk - low level/low temp/high temp
 - Y3 = Heating Control cable

MAIN JUNCTION BOX IN ADB CP DISPENSER

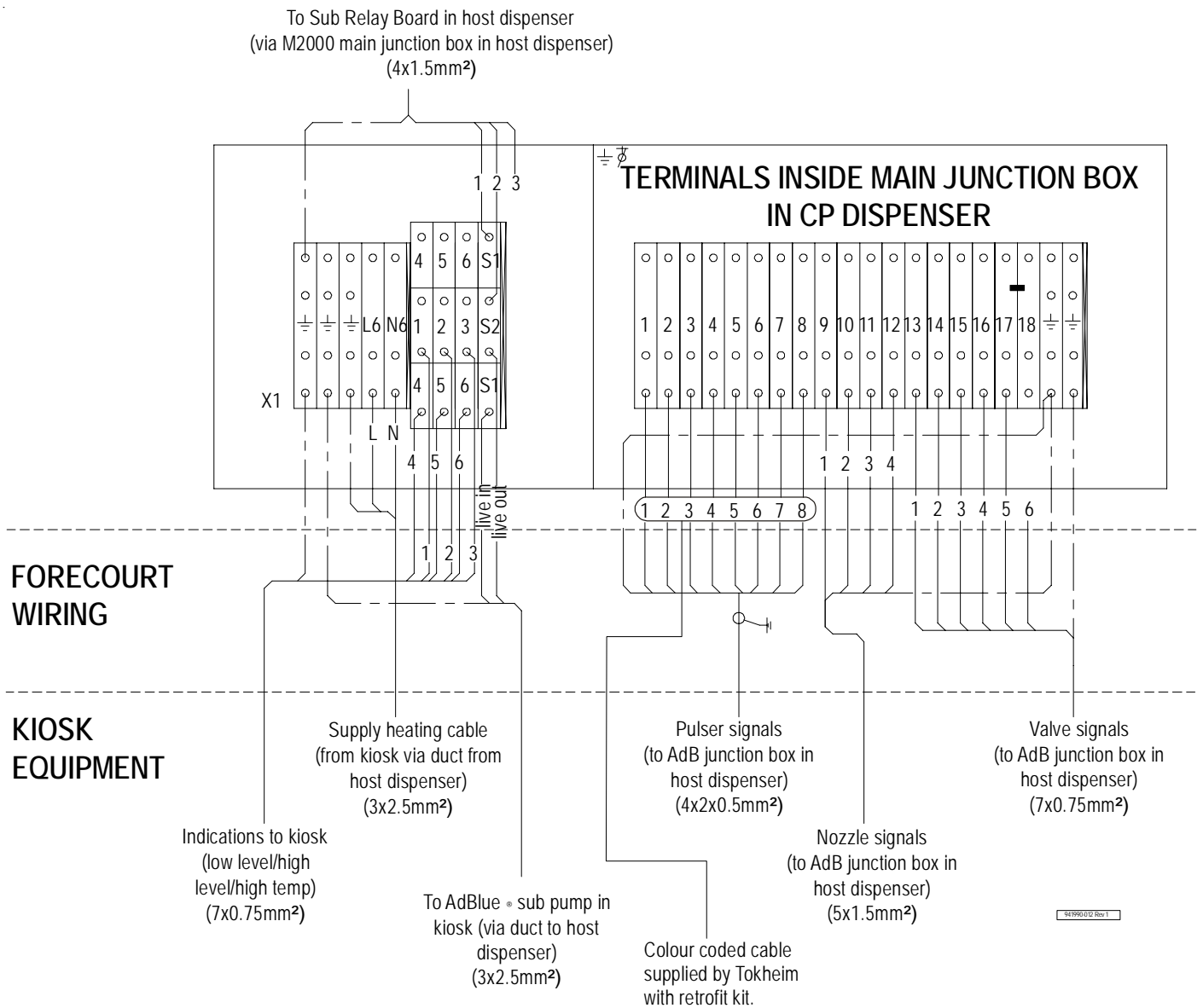

5.11 Electrical Options

5.11.1 FIRE AND/OR SHOCK DETECTION

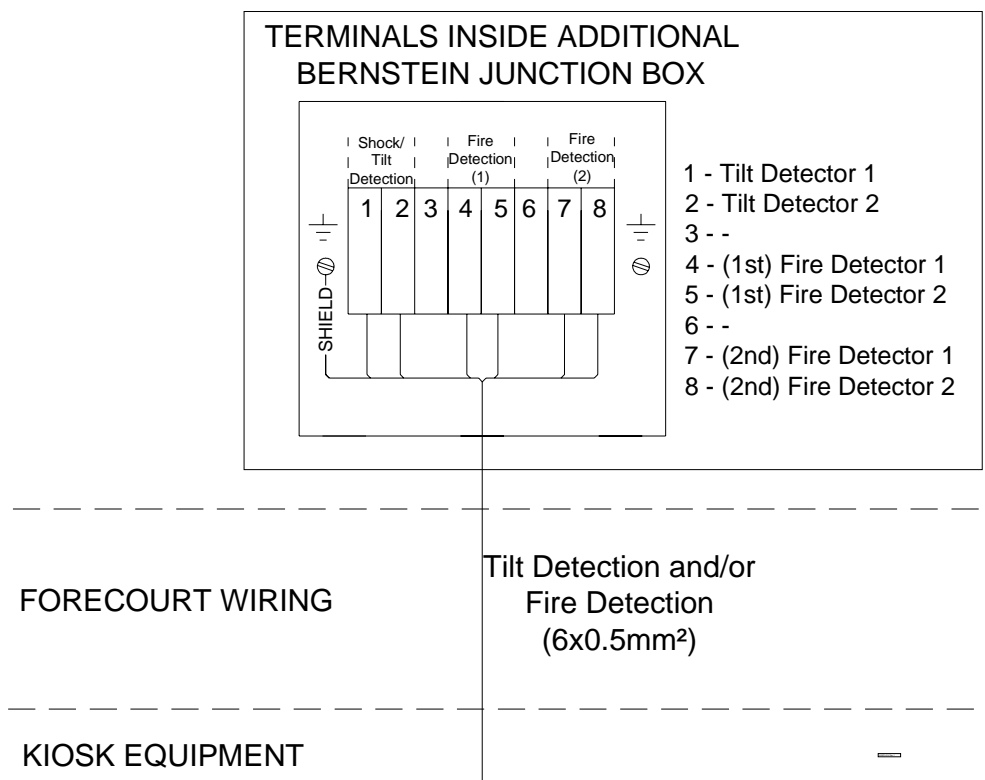

5.11.2 AUDIO/SPEAKER

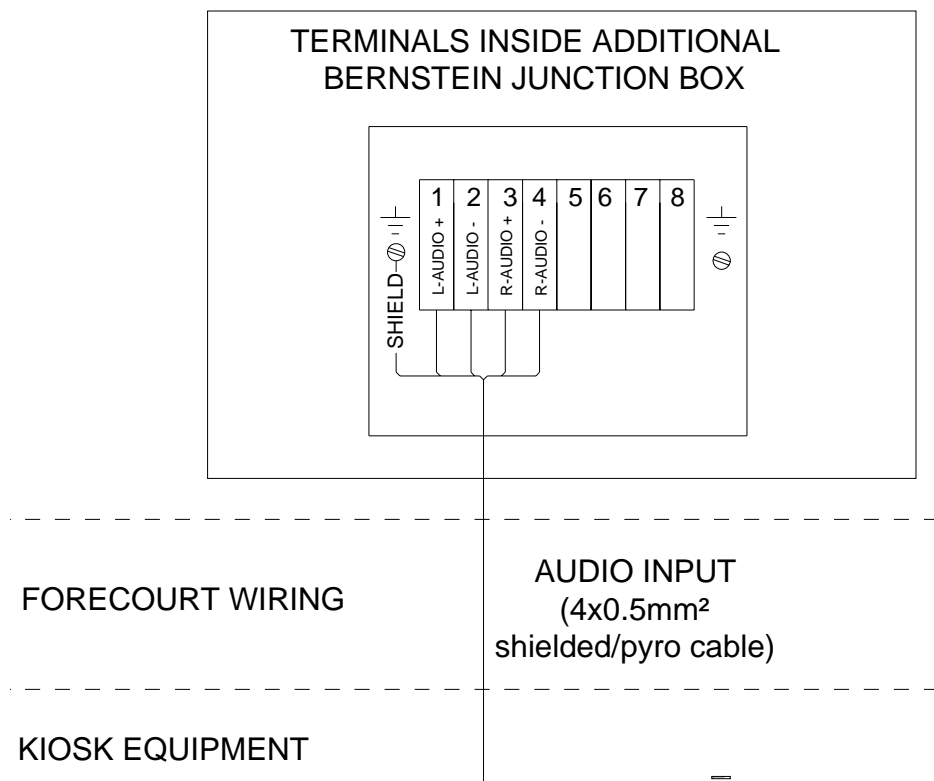

5.11.3 SLIDING DOOR AND/OR LOW TEMPERATURE ALARM

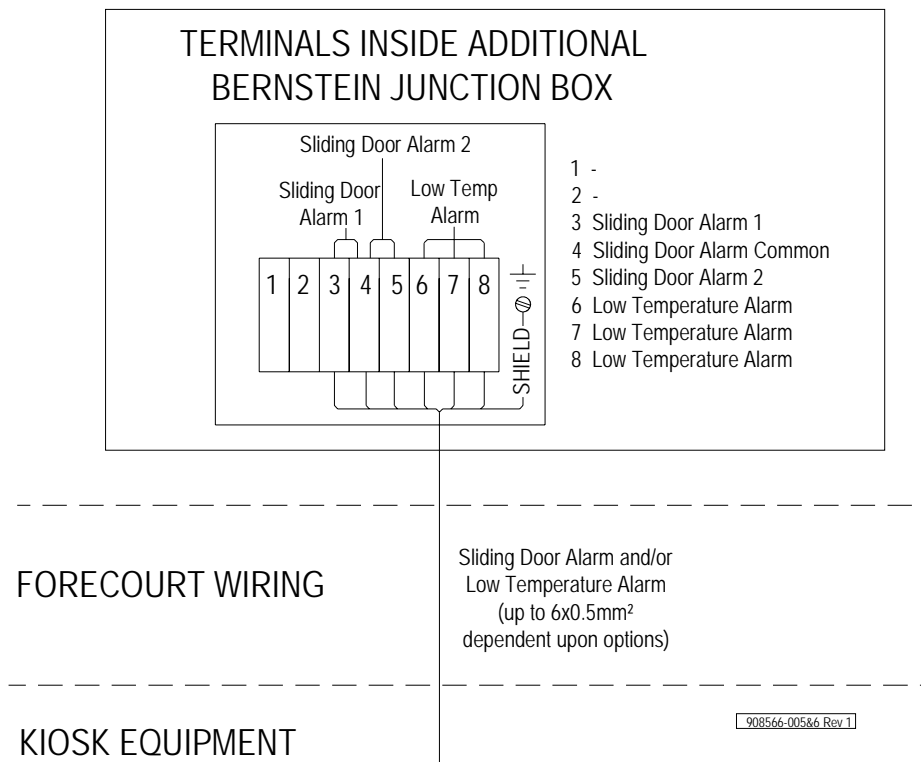

5.11.4 SPECIAL DISPENSER CONFIGURATIONS

Certain protocols require the use of an additional Bernstein box to house additional comms when combined with options such as DIT and audio.

Standalone AdB & AdB with Container dispensers

ZSR, M32, DUN, LON, KIENZLE, TOK, EIN, 82D, AUTOTANK protocols using 4 terminals

EPS/TATSUNO, LOG, DRESSER protocols using 5+ terminals

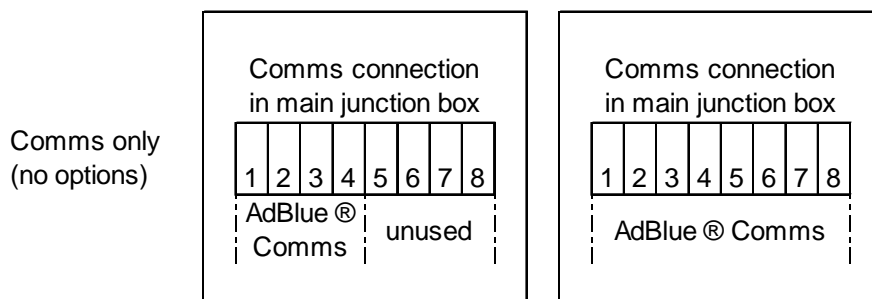

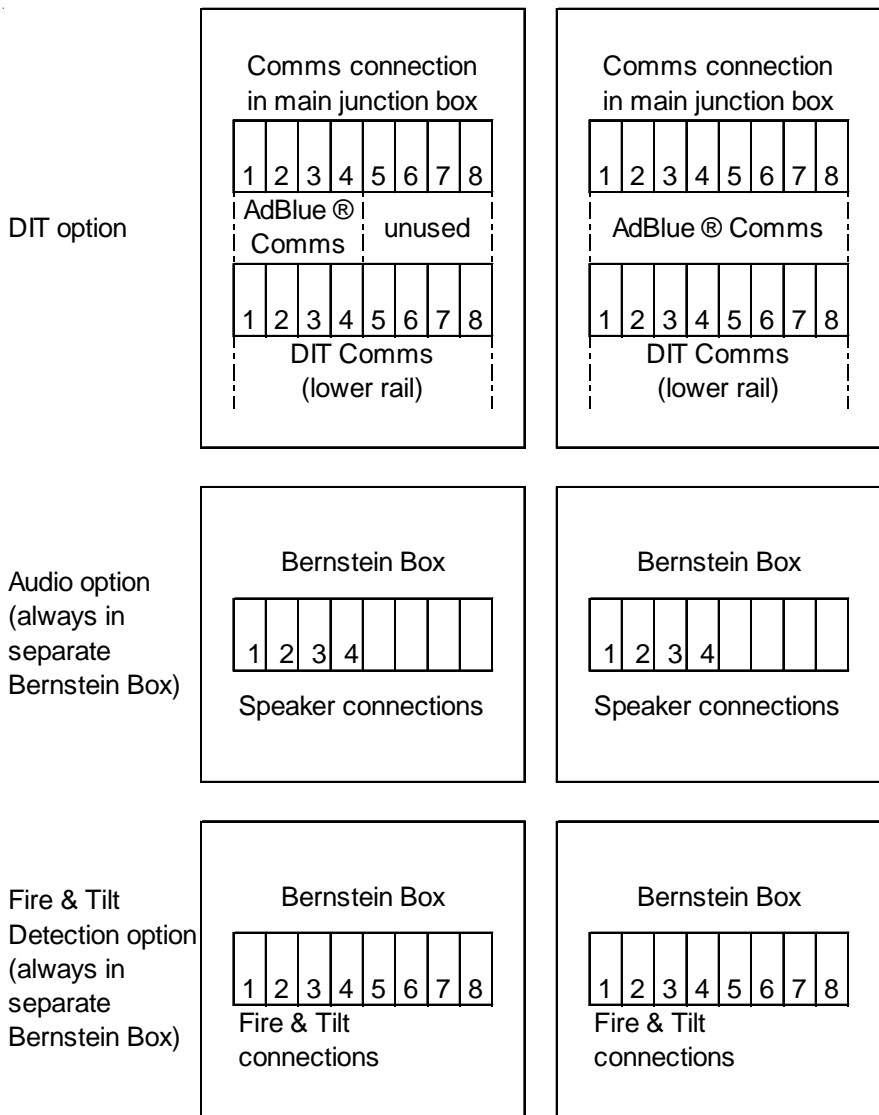

5.12 Communications Wiring in Main Junction Box

Communications wiring in the main junction box will vary according to the different communication protocols.

Up to four terminal comms

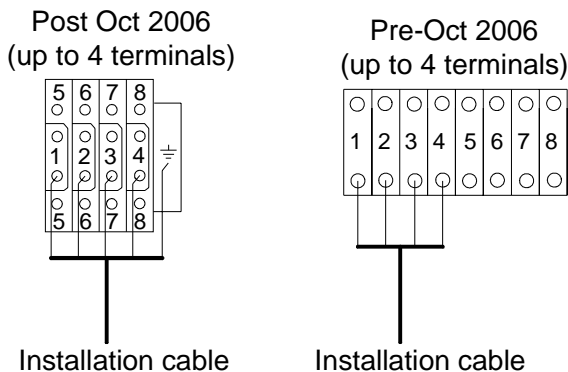

IMPORTANT
Screen and unused wires must be cut as close as possible to cable glands

Ensure wiring in dispenser matches wiring in kiosk

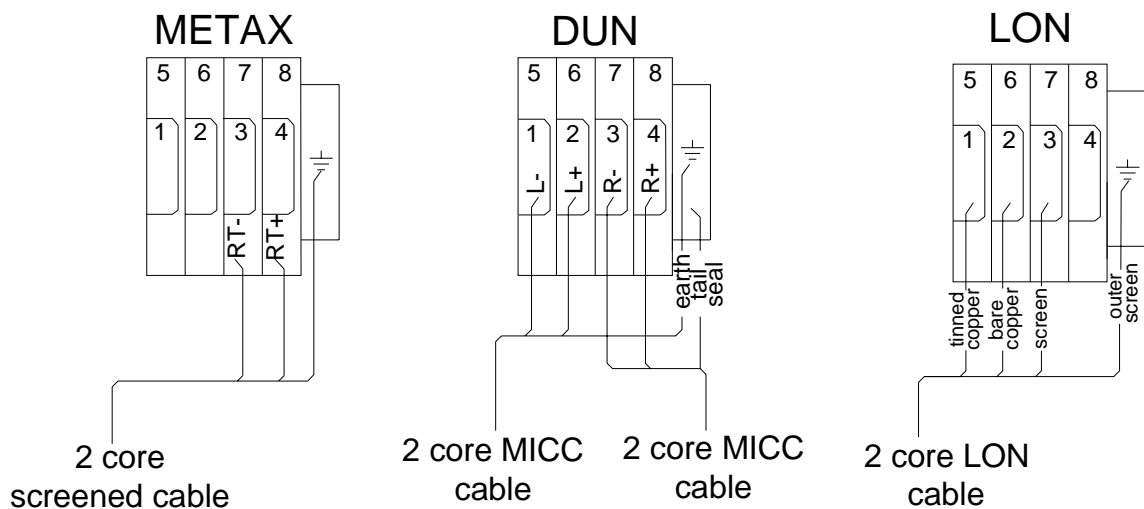
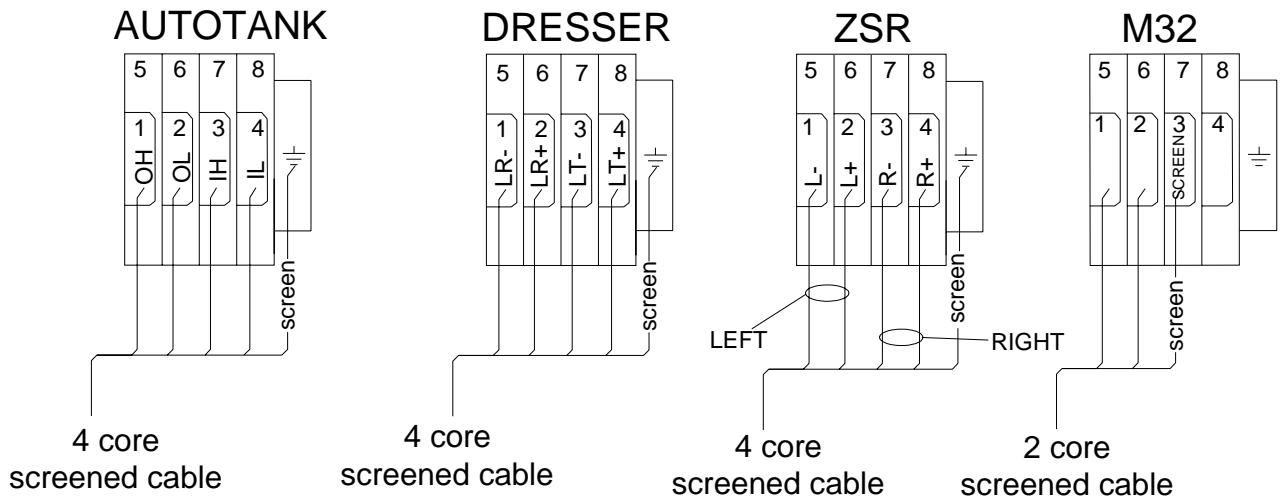
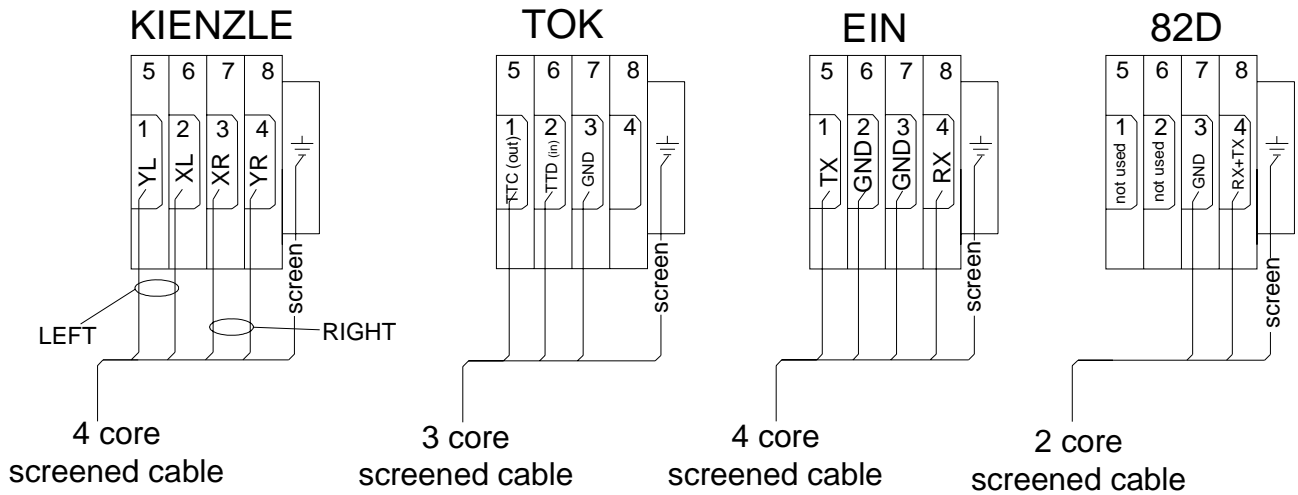

Up to eight terminal comms

Post Oct 2006
(8 terminals)

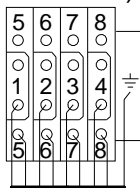

Installation cable

Pre-Oct 2006
(8 terminals)

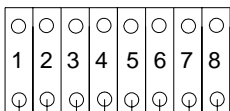

Installation cable

IMPORTANT

Screen and unused wires must be cut as close as possible to cable glands

Ensure wiring in dispenser matches wiring in kiosk

**EPS/
TATSUNO**

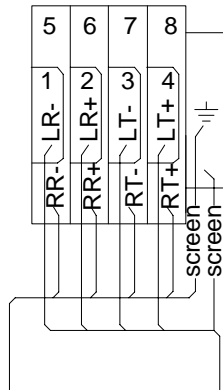

From KCD Left From KDC Right or Tatsuno

LOG

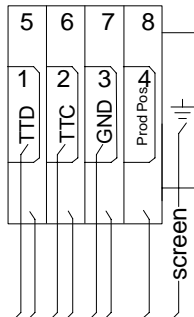

Info from shop

**NUOVO
PIGNONE**

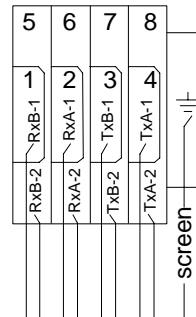

Info from shop

EPSI INTERFACE

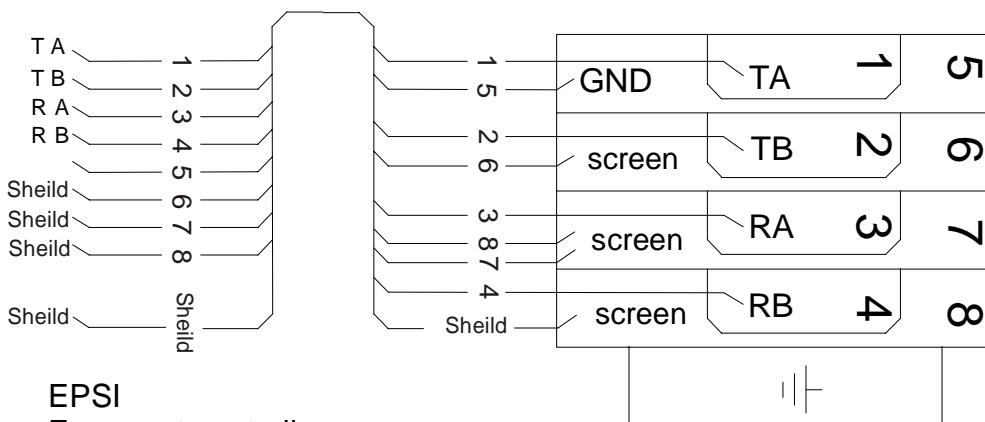

EPSI
Forecourt controller

Communication section
in main junction box

5.13 Current ratings for AdBlue dispensers**ADBLUE 1-1 OR 1-2**

Without heating : 230V, 50/60Hz, 1amp

With standard heating: 230V, 50Hz, 6amps

With ATEX electric heating : 230V, 50Hz, 5.6amps

With ATEX water heating : 230V, 50HZ, 14.5amps

ADBLUE CP 2 HOSE MODULE

Without heating : 24V DC, 0.4amp

With standard heating: 230V, 50Hz, 5amps and 24V DC, 0.4amp

With ATEX electric heating : 230V, 50Hz, 4.6amps and 24V DC, 0.4amp

With ATEX water heating : 230V, 50HZ, 13.5amps and 24V DC, 0.4amp

ADBLUE MC 2 HOSE MODULE

Without heating : 24V DC, 0.4amp

With standard heating: 230V, 50Hz, 5amps and 24V DC 0.4 amp

For single sided CP and MC dispensers the 24V DC at 0.4amp becomes 0.2amp

This page is intentionally blank

CONTENTS

6 COMMISSIONING 6-2

- 6.1 Test and Programming the Dispenser 6-2
 - 6.1.1 Program the Dispenser 6-2
 - 6.1.2 Dispenser Functions 6-2
 - 6.1.3 Test the Dispenser 6-2
- 6.2 Calibration of the Dispenser 6-4
 - MID Certified Dispensers 6-4
 - 6.2.1 Calibrate the Meter 6-4
 - 6.2.2 Disposal of AdBlue ® Calibration Test Fuel 6-4
- 6.3 Final Checks 6-5
- 6.4 Handing over to the Station Manager 6-5

6 COMMISSIONING

The procedures in this section are Tokheim recommended procedures for commissioning the dispenser but differences may exist in the standards relating to commissioning in different countries and local regions, in which case the local and/or national standards must be employed.



IMPORTANT : Prior to commissioning or running the meter, ensure the ambient temperature within the hydraulic system is kept above 10°C. for a minimum of 5 hours. Use the dispenser heater if necessary.

Follow the instructions given in section 4.7 to gain access to the calculator head.

6.1 Test and Programming the Dispenser

Prior to Commissioning, the following must be checked:-

- Ensure that all the cabling and hydraulic connections have been made correctly.
- Check that power is present.

Note : Disconnect the Comms before switching on power to the dispenser. This will reduce the possibility of errors.

- Check that the voltage of power supply is in accordance with the WWC calculator voltage.
- Check that the back-up battery is connected and in correct working order.

6.1.1 PROGRAM THE DISPENSER

- If permitted, use the User Access Keypad (UAK) to place the dispenser(s) in Stand-alone Mode and enter the unit prices.
- Alternatively, use the UAK to place the dispenser in Self-Service Mode. Re-program the console for the new dispenser. The unit prices will be communicated automatically to the dispenser.
- Check the unit prices are correct for each new dispenser.
- Where applicable, note the readings on the electronic and mechanical totalisers.

6.1.2 DISPENSER FUNCTIONS

- Where fitted, check that the leakage plates are correctly installed.
- Carry out a test filling using each nozzle and check all supported functions are working correctly (local preset, HS/LS, etc.).
- Check that the nozzles correspond to the correct products and that product names are correct.
- Check the correct operation of all hose retraction systems.
- Check the correct operation of all locks.
- Check the calculator lighting (where applicable).
- Check that all required warning stickers are in the correct positions.

6.1.3 TEST THE DISPENSER

Calibration containers used for diesel or petrol must **NOT** be used in the calibration of AdBlue® liquid. Special AdBlue® resistant calibration equipment must be reserved for calibration of AdBlue® liquid only.

A special ring magnet is required to activate the Elaflex AdB nozzle.

AdBlue® THERMOSTATS & HEATERS (HEATING OPTION ONLY)

Where AdBlue® dispensers are fitted with thermostatically controlled heaters (optional), which are designed to prevent the AdBlue® liquid from freezing in the dispenser when temperatures fall below -5°C. The following tests must be performed to check correct operation of heater/thermostats:-

- Set adjustable thermostat(s) on the dispenser to -5°C.
- Set the adjustable thermostat on the container to -5°C.
- Measure the current on the container heating cable using a multi meter.
- Test operation of thermostat(s)/ er(s) by use of a freeze spray on the contacts in the hose cassette area.



FLOW RATES

The following procedures must be performed at each nozzle position:-

- Test the flow rates (litres/minute) - refer to the WWC Calculator Manual.
- Where applicable, test the Vapour Recovery for correct operation.
- Test the meters are within the legal requirements:-

Lift each nozzle and deliver approximately 20 litres into a Tokheim approved calibrated container until all air and fuel substitute has been expelled through the nozzle and/or air vent pipes.



Note : Discard this filling since it will contain fuel substitute from the dispenser pipes and components and air from the supply pipes.

IMPORTANT : DISCARD ALL TEST FILLINGS SAFELY. REFER TO SECTION 6.2.2 FOR ADBLUE® DISPOSAL GUIDELINES.

- Perform a test filling into the calibrated container until 20 litres have been dispensed according to the calculator display.
- Read the measurement on the calibrated container.

If the fuel dispensed into the container is above or below the calibration line (i.e. greater or less than the 20 litres dispensed) then the meter must be adjusted to ensure Weights & Measures (W&M) compliance.

Note : W&M regulations vary according to different countries.

6.2 Calibration of the Dispenser

If the meter is fitted with an enhanced pulser for electronic calibration (MPE-EC) or temperature compensation (MPE-TC) then it should not be necessary to perform mechanical calibration.

MID Certified Dispensers

MID certified dispensers are calibrated in the factory with the relevant seals stamped so it can be put into operation immediately upon installation without Weights & Measures verification. Refer to section 1.7 for the identification of MID dispensers.

A calibration check should be performed as part of the Commissioning procedure. If the calibration is outwith legal tolerances, the factory MID verification is invalidated. The meter should be adjusted accordingly then a local National verification will need to be performed before the dispenser can be used.

6.2.1 CALIBRATE THE METER

- Carefully remove the W&M seal on the TM80/TM80 AdB Meter.

Note : Store the seal in a safe place for re-use.

- Use a TX30 bit to remove the hexalobular screw on the plastic protective cover on the TM80/TM80 AdB meter.
- Use a 10mm spanner to calibrate the piston meter by turning **BOTH** adjustment screws.



Note : If the error is greater than 0.05% then balance the error by adjusting both screws equally.

- Adjust in a clockwise direction to reduce the amount of fuel delivered i.e. if the fuel in the container is greater than the reading on the calculator display.
- Adjust in an anti-clockwise direction to increase the amount of fuel delivered i.e. if the fuel in the container is less than the reading on the calculator display.

Note : each “click” per adjustment screw corresponds to approximately 0.05% or 10ml.

- Re-test the dispenser until calibration is within acceptable tolerance levels.
- Replace the W&M seals to the adjusted meter(s).



IMPORTANT : AdBlue ® liquid used in calibration must be disposed of according to local/national regulations for chemical waste disposal.

6.2.2 DISPOSAL OF AdBLUE ® CALIBRATION TEST FUEL

To reduce the risk of potential contamination, Tokheim recommends disposal of the first 20 litres of calibration as chemical waste. Any remaining AdBlue ® liquid can then be carefully returned to the AdBlue ® container or tank.

6.3 Final Checks

- Check that all W&M requirements have been fulfilled.
- Where applicable, use the UAK to check the limit of the High Speed Diesel as per W&M regulations.
- Where applicable, note the readings on the electronic and mechanical totalisers.
- Where applicable, clear the error counters.
- Note the type/serial number(s) of the dispenser(s).
- Complete the Arrival Quality checklists and country specific product identification forms for the dispensers and return them to the local Sales & Service Division.

6.4 Handing over to the Station Manager

Explain to the Station Manager the working of the dispenser(s) and train him in their use (according to the User Manual).

Together with the Station Manager, go through the Acceptation checklist to check that everything has been delivered as ordered and is in good condition. Both the Service Engineer/Technician and Station Manager must sign the checklist.

The Station Manager must check the unit prices.

Hand over the following documents to the Station Manager:-

- One copy of the installation report including the totals of all totalisers and the type and serial numbers of dispenser(s).
- User Manual.
- Declaration of Conformity (usually located in the Calculator Head).
- Copy of signed Acceptation checklist (usually located in the Calculator Head).
- All keys.

This page is intentionally blank

GLOSSARY OF TERMS USED IN THIS MANUAL

CP : COMBO PREPARED
VHS : VERY HIGH SPEED
T : TANK
MCP : MINI COMBO PREPARED
DIT : DISPENSER INTEGRATED TERMINALS
OPT : OUTDOOR PAYMENT TERMINALS
POS : POINT OF SALE
MICC : MINERAL INSULATED COPPER CLAD CABLE
RCD : RESIDUAL CURRENT DEVICE
HMS : HOSE MANAGEMENT SYSTEM
UAK : USER ACCESS KEYPAD
HS / LS : HIGH SPEED / LOW SPEED
WWC : WORLD WIDE CALCULATOR
W&M : WEIGHTS AND MEASURES
MPE-EC : ENHANCED PULSER METER, ELECTRONIC CALIBRATION
MPE-TC : ENHANCED PULSER METER, TEMPERATURE CALIBRATION
TM80 : TOKHEIM METER



NL Spare Parts
Koppens Automatic (Bladel)
Industrieweg 5
5531 AD Bladel
The Netherlands
☎ +31 497 389 555
☎ +31 497 381 950

GB Manufacturing
Unit 3, Baker Road
West Pitkerro Industrial Estate
Dundee DD5 3RT
Scotland
☎ +44 (0)1382 598000
☎ +44 (0)1382 598001

F Manufacturing
Route de Soliers
14540 Grentheville
BP268, Caen Cedex 14013
France
☎ +33 231 15 15 15
☎ +33 231 23 15 06

EUROPE

A Austria
Tokheim Austria GMBH
Eitzenberger Strasse 4-6
A-2544 Leobersdorf
☎ +43 (0) 2256 606 0
☎ +43 (0) 2256 606 170
✉ office@leobersdorf.tokheim.com

B Belgium
Tokheim
Everdongenlaan 31
2300 Turnhout
☎ +32 (0) 14 44 85 00
☎ +32 (0) 14 44 85 55
✉ sales@turnhout.tokheim.com

CZ Czech Republic
Tokheim
Pernerova 48
CZ-18602 Prague 8
☎ +420 224 890 312
☎ +420 222 327 267
✉ pribrsky@prague.tokheim.com

DK Denmark & Scandinavia
Tokheim Scandinavia A/S
Hejrevang 10
3450 Allerød
☎ +45 48 13 45 45
☎ +45 48 17 45 96
✉ service@alleroed.tokheim.com

F France - Le Plessis
Tokheim Services France
9 Avenue Galilée
92350 Le Plessis-Robinson
☎ +33 (0)1 41 36 13 00
☎ +33 (0)1 41 36 13 70
✉ info@tokheim-services.com

F Tokheim Europe & Africa Headquarters
ZAC Paris Nord 2
B.P. 40027 Tremblay-en-France
95912 Roissy C.D.G. Cedex
☎ +33 (0)1 49 90 77 00
☎ +33 (0)1 49 90 77 77
✉ marcom@tremblay.tokheim.com

D Germany
Tokheim GmbH
Lothstrasse 1a
D-80335 München
☎ +49 (0)89 189 53 0
☎ +49 (0)89 189 53 148
✉ service@muenchen.tokheim.com

I Italy
Tokheim Soffitam Italia S.r.l.
Quattordio Km 10800
S.P. 26
14030 Scuzolengo (AT)
☎ +39 0141 2038200
☎ +39 0141 2038222
✉ info@asti.tokheim.com

SALES & SERVICE DIVISIONS

NL Netherlands
Tokheim Netherlands B.V.
Touwslagerstraat 17
Postbus 4186
2980 GD Ridderkerk
☎ +31(0) 180 48 15 00
☎ +31(0) 180 48 15 55
✉ sales@ridderkerk.tokheim.com

PL Poland
Pol-Germann Tokheim Sp. z.o.o.
ul. Narwicka 1
PL-80-557 Gdansk
☎ +48 58 343 21 71
☎ +48 58 343 22 15
✉ pol-germann@tokheim.pl

P Portugal
G.N.C.
Parque de Ciencia e Tecnologia
Edificio Tecnologia 1, N° 27
2780-920 Oeiras
Lisboa
☎ +351 214 220 420
☎ +351 214 214 226

RUS Russia & CIS Countries
Tokheim Representative Office
Room 313, Hotel "Ukraina"
Kutuzovski Prospekt, 2/1
Stroyenie 1
Moscow 121249
☎ +7 095 933 69 35
☎ +7 095 933 69 34
✉ kolobov@dol.ru

SK Slovak Republic
Tokheim
Mlynske Nivy 70
SK-82015 Bratislava
☎ +421 2 58 27 02 15
☎ +421 2 52 41 41 23
✉ schroeder@berlin.tokheim.com

E Spain
Tokheim Koppens Iberica S.A.
Calle La Granja, 41
Poligono Industrial de Alcobendas
28108 Alcobendas (Madrid)
☎ +34 91 2030465
☎ +34 91 6614130
✉ urra@madrid.tokheim.com

CH Switzerland
Tokheim Switzerland AG/SA/LTD
Route du Crochet 7
Case Postale 50
1762 Givisiez
☎ +41 (0)26 460 51 11
☎ +41 (0)26 460 51 12
✉ user@givisiez.tokheim.com

GB United Kingdom
Unit 1, Baker Road
West Pitkerro Industrial Estate
Dundee DD5 3RT
Scotland
☎ +44 (0)1382 483500
☎ +44 (0)1382 731835
✉ service@tokheimuk.com

MIDDLE EAST, SOUTH & CENTRAL AMERICA

F Export Division
ZAC Paris Nord 2
B.P. 40027 Tremblay-en-France
95912 Roissy C.D.G. Cedex
France
☎ +33 (0)1 49 90 77 56
☎ +33 (0)1 49 90 77 93
✉ marcom@tremblay.tokheim.com

AFRICA
RFC Cameroon
Socatam S.A.
BP 3941
Douala
☎ +237 40 57 86
☎ +237 40 57 88
✉ socatam.douala@camnet.cm

MA Morocco
Matam S.A.
209 Bld Moulay Ismail
Route de Rabat
Casablanca
☎ +212 22 40 40 24
☎ +212 22 40 40 21
✉ matam@wanadoo.net.ma

SN Senegal
Cosetam S.A.
Quartier de Bel Air
Route des Hydrocarbures
BP 1237
Dakar
☎ +221 832 23 71
☎ +221 832 68 34
✉ cosetam@ns.arc.sn

ZA South Africa
Tokheim South Africa Ltd
Stand 110, Precision Road
Kya Sand
Randburg
☎ +27 11 462 2105
☎ +27 11 462 1942
✉ tokheimsales@tokheim.co.za

TN Tunisia
Cottam SARL
116 Ave de l'Union du Maghreb Arabe
BP 117
La Soukra
2036 Tunis
☎ +216 175 95 50
☎ +216 175 95 30
✉ cottam@cottam.com.tn

ASIA
AE Tokheim
PO Box 16869
JAFZ
Dubai, UAE
☎ +971 4 881 3305
☎ +971 4 881 4463
✉ tokheim@emirates.net.ae

As Tokheim regularly improves its products to ever better respond to evolving market and regulatory requirements, it reserves the right to change any of the specifications of these products, and this without prior notice.

For technical manual enquiries,
contact: author@dundee.tokheim.com