

SPECIFICATIONS

HW160

ENGINE			
Maker / Model		Cummins QSB6.7	
Type		Water-cooled, 4-cycle diesel, 6-cylinder in-line, Direct injection, Turbocharged, Charge air cooled, Low emission	
Rated flywheel horse power	SAE	J1995 (gross)	134 kW (180 HP) at 1,800 rpm
		J1349 (net)	127 kW (171 HP) at 1,800 rpm
	DIN	6271/1 (gross)	134 kW (182 PS) at 1,800 rpm
		6271/1 (net)	127 kW (173 PS) at 1,800 rpm
Max. torque		85.7 kgf·m (620 lbf·ft) at 1,500 rpm	
Bore x stroke		107 x 124 mm (4.21" x 4.88")	
Piston displacement		6,700 cc (409 cu in)	
Batteries		2 x 12 V x 100 Ah	
Starting motor		24 V - 4.8 kW	
Alternator		24 V - 95 A	

HYDRAULIC SYSTEM	
MAIN PUMP	
Type	Two variable displacement piston pumps
Max. flow	2 x 172 l/min (45.4 US gpm/37.8 UK gpm)
Sub-pump for pilot circuit	Gear pump

Cross-sensing and fuel saving pump system

HYDRAULIC MOTORS	
Travel	Bent - axis pistons motor with brake valve and parking brake
Swing	Axial piston motor with automatic brake

RELIEF VALVE SETTING	
Implement circuits	350 kgf/cm ² (4,970 psi)
Travel	380 kgf/cm ² (5,400 psi)
Power boost (boom, arm, bucket)	380 kgf/cm ² (5,400 psi)
Swing circuit	285 kgf/cm ² (4,050 psi)
Pilot circuit	40 kgf/cm ² (570 psi)
Service valve	Installed

HYDRAULIC CYLINDERS	
No. of cylinder bore x stroke	Boom: 2-110 x 1,090 mm (4.1" x 42.9")
	Arm: 1-115 x 1,235 mm (4.72" x 53.3")
	Bucket: 1-105 x 995 mm (4.3" x 39.17")
	Dozer Blade: 2-110 x 235 mm (4.3" x 9.25")
	Outrigger: 2-125 x 463 mm (4.9" x 18.7")
	2-Piece Boom: 2-110 x 960 mm (4.5" x 37.79")
	Adjust (boom): 1-160 x 650 mm (6.29" x 25.59")

DRIVES & BRAKES		
4-wheel hydrostatic drive. Constant mesh, helical gear transmission provides 2 forward and reverse travel speeds.		
Max. drawbar pull	10,720 kgf (23,636 lbf)	
Travel speed	1st	9.5 km/h
	2nd	35 km/h
Gradeability	35° (70 %)	

Parking brake : Independent dual brake, front and rear axle full hydraulic power brake.
 - Spring released and hydraulic applied wet type multiple disk brake.
 - Transmission is locked at neutral position for parking, automatically.

CONTROL	
Pilot pressure operated joysticks and pedals with detachable lever provide almost effortless and fatigueless operation.	

CONTROL	
Pilot control	Two joysticks with one safety lever (LH): Swing and arm (RH): Boom and bucket (ISO)
Engine throttle	Electric, Dial type
Lights	Two lights mounted on the boom, one under the battery box and one under the cabin

AXLE & WHEEL	
Full floating front axle is supported by center pin for oscillation. It can be locked by oscillation lock cylinders. Rear axle is fixed on the lower chassis.	
Tires	10.00-20-14PR, Dual (tube type)
(Optional)	10.00-20, Dual (solid type) 10.00-20-14PR, Dual (tube type)

STEERING SYSTEM	
Hydraulically actuated, orbitrol type steering system actuates on front wheels through the steering cylinder.	
Min. turning radius	6,300 mm (20' 8")

SWING SYSTEM	
Swing motor	Fixed displacement axial piston motor
Swing reduction	Planetary gear reduction
Swing bearing lubrication	Grease-bathed
Swing brake (option)	Multi wet disc
Swing speed	9.3 rpm

SERVICE REFILL CAPACITIES (): option				
Re-filling	liter	US gal	UK gal	
Fuel tank	290	76.6	63.8	
Engine coolant	19.5	5.2	4.3	
Engine oil	23.7	6.26	5.21	
Swing device - gear oil	6.2 (5.0)	1.64 (1.3)	1.36 (1.09)	
Swing device - grease	(1.2)	(0.32)	(0.26)	
Axle	Front	15.5	4.09	3.41
	Rear	17.5	4.62	3.85
Hydraulic system (including tank)	270	71.3	59.4	
Hydraulic tank	125	33.0	27.5	
DEF/AdBlue®	27	7.1	5.9	

UNDERCARRIAGE	
Reinforced box-section frame is all-welded, low-stress. Dozer blade and outriggers are available. A pin-on design.	
Dozer blade	A very useful addition for leveling and back filling or clean-up work.
Outrigger	Indicated for max. operation stability when digging and lifting. Can be mounted on the front/or the rear.

OPERATING WEIGHT (APPROXIMATE)		
Operating weight, including 5,000 mm (16' 5") Mono boom; 2,200 mm (7' 3") arm; SAE heaped 0.70 m ³ (0.91 yd ³) backhoe bucket, lubricant, coolant, full fuel tank, full hydraulic tank and all standard equipments.		
OPERATING WEIGHT	Mono boom	2-Piece Boom
Rear dozer blade	17,100 kg (37,700 lb)	17,570 kg (38,735 lb)
Rear outriggers	17,250 kg (38,030 lb)	17,720 kg (39,066 lb)
Front outriggers and rear blade	18,050 kg (39,790 lb)	18,520 kg (40,830 lb)
Front blade and rear outriggers	18,100 kg (39,900 lb)	18,570 kg (40,940 lb)
Four outriggers	18,200 kg (40,120 lb)	18,670 kg (41,160 lb)

BUCKET SELECTION GUIDE & DIGGING FORCE

HW160

BUCKETS

All buckets are welded with high-strength steel.



0.39 (0.51)



0.50 (0.65)



0.64 (0.84)
0.70 (0.92)
0.76 (0.99)



0.70 (0.92)

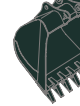

0.89 (1.16)
1.05 (1.37)



■ 0.69 (0.90)

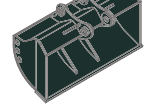

⊙ 0.75 (0.90)

SAE heaped
m³ (yd³)

Capacity m ³ (yd ³)		Width mm (in)		Weight kg (lb)	Recommendation mm (ft.in)			
					5,000 (16' 5") Mono-boom		5,100 (16' 9") 2-Piece boom	
SAE heaped	CECE heaped	Without side cutters	With side cutters		2,200 (7' 3") Arm	2,500 (8' 2") Arm	2,200 (7' 3") Arm	2,500 (8' 2") Arm
0.39 (0.51)	0.34 (0.44)	650 (25.6)	740 (29.1)	410 (900)	●	●	●	●
0.50 (0.65)	0.44 (0.58)	790 (31.1)	880 (34.6)	470 (1,040)	●	●	●	●
0.64 (0.84)	0.55 (0.72)	950 (37.4)	1,040 (40.9)	510 (1,120)	●	●	●	●
0.70 (0.92)	0.60 (0.78)	1,020 (40.2)	1,110 (43.7)	600 (1,320)	●	■	■	■
0.76 (0.99)	0.65 (0.85)	1,090 (42.9)	1,180 (46.5)	620 (1,370)	■	■	■	▲
0.89 (1.16)	0.77 (1.01)	1,250 (49.2)	1,340 (52.8)	610 (1,340)	▲	▲	▲	▲
1.05 (1.37)	0.90 (1.18)	1,430 (56.3)	1,520 (59.8)	680 (1,500)	▲	-	▲	-
■ 0.69 (0.90)	0.62 (0.81)	1,050 (41.3)	-	720 (1,590)	■	■	■	■
⊙ 0.75 (0.98)	0.65 (0.85)	1,820 (71.7)	-	540 (1,190)	●	■	●	■

- Heavy duty bucket
- ⊙ Ditching bucket

- : Applicable for materials with density of 2,000 kg /m³ (3,370 lb/ yd³) or less
- : Applicable for materials with density of 1,600 kg /m³ (2,700 lb/ yd³) or less
- ▲ : Applicable for materials with density of 1,100 kg /m³ (1,850 lb/ yd³) or less

ATTACHMENT

Booms and arms are welded with a low-stress, full-box section design.

5.0 m (16' 5") Mono-boom and 5.1 m (16' 9") 2-Piece boom and 2.2 m (7' 3") & 2.5 m (8' 2") Arms are available.

DIGGING FORCE

Arm	Length	mm (ft.in)	2,200 (7' 3")	2,500 (8' 2")	Remarks:
	Weight	kg (lb)	750 (1,650)	810 (1,790)	
Bucket digging force	SAE	kN	98.1 [106.5]	98.1 [106.5]	[]: Power Boost
		kgf	10,000 [10,860]	10,000 [10,860]	
		lbf	22,050 [23,940]	22,050 [23,940]	
	ISO	kN	113.4 [123.1]	113.4 [123.1]	
		kgf	11,560 [12,550]	11,560 [12,550]	
		lbf	25,490 [27,670]	25,490 [27,670]	
Arm crowd force	SAE	kN	76.0 [82.5]	66.4 [72.1]	
		kgf	7,750 [8,410]	6,770 [7,350]	
		lbf	17,090 [18,550]	16,930 [16,210]	
	ISO	kN	79.4 [86.2]	69.1 [75.1]	
		kgf	8,100 [8,790]	7,050 [7,650]	
		lbf	17,860 [19,390]	15,540 [16,870]	

Note : Arm weight includes bucket cylinder, linkage and pin

DIMENSIONS & WORKING RANGE

HW160

HW160 MONO BOOM DIMENSIONS

5.0 m (16' 5") Mono-boom and 2.2 m (7' 3") Arm and rear dozer blade.

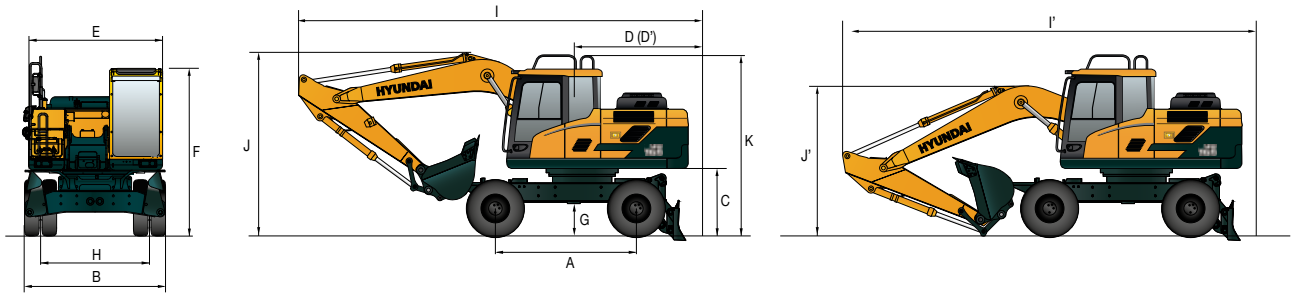

Unit : mm (ft-in)

A	Wheel base	2,600 (8' 6")
B	Overall width	2,500 (8' 2")
C	Ground clearance of counterweight	1,270 (4' 2")
D	Rear-end distance	2,430 (8' 0")
D'	Rear-end swing radius	2,430 (8' 0")
E	Upperstructure width	2,475 (8' 1")
F	Overall height of cab	3,190 (10' 6")
G	Min. ground clearance	340 (1' 1")
H	Tread	1,914 (6' 3")
K	Overall height of guardrail	3,450 (11' 4")

Boom length	5,000 (16' 5")	
Arm length	2,200 (7' 3")	2,500 (8' 2")
I	Overall length (Traveling position)	8,400 (27' 7")
I'	Overall length (Shipping position)	8,490 (27' 10")
J	Overall height of boom (Traveling position)	3,460 (11' 4")
J'	Overall height of boom (Shipping position)	3,180 (10' 5")

HW160 MONO BOOM WORKING RANGE

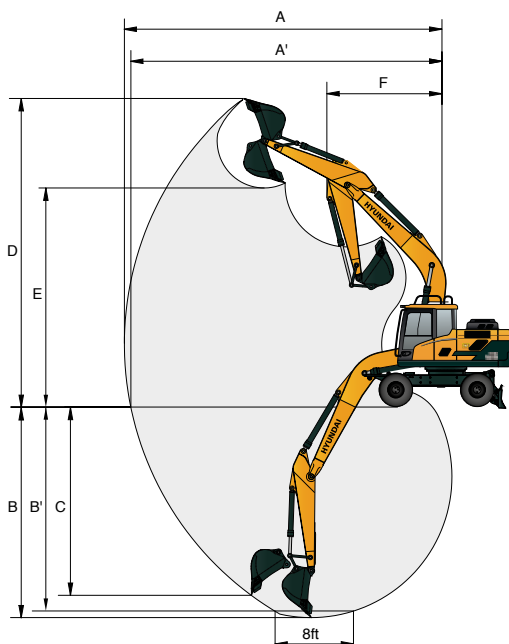

Unit : mm (ft-in)

Boom length	5,000 (16' 5")	
Arm length	2,200 (7' 3")	2,500 (8' 2")
A	Max. digging reach	8,570 (28' 1")
A'	Max. digging reach on ground	8,360 (27' 5")
B	Max. digging depth	5,350 (17' 7")
B'	Max. digging depth (8' level)	5,120 (16' 10")
C	Max. vertical wall digging depth	4,710 (15' 5")
D	Max. digging height	8,830 (29' 0")
E	Max. dumping height	6,210 (20' 4")
F	Min. front swing radius	3,310 (10' 10")

DIMENSIONS & WORKING RANGE

HW160

HW160 2-PIECE BOOM DIMENSIONS

5.1 m (16' 9") 2-Piece boom and 2.2 m (7' 3") Arm and rear dozer blade.

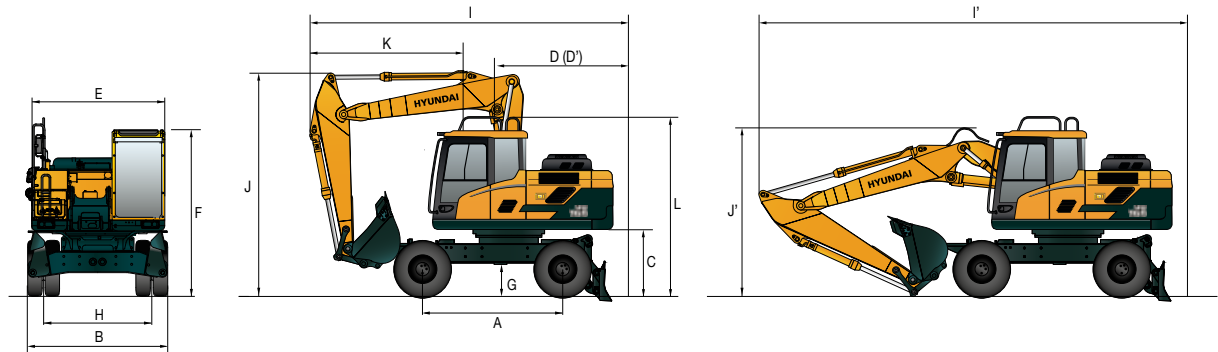

Unit : mm (ft-in)

A	Wheel base	2,600 (8' 6")
B	Overall width	2,500 (8' 2")
C	Ground clearance of counterweight	1,270 (4' 2")
D	Rear-end distance	2,430 (8' 0")
D'	Rear-end swing radius	2,430 (8' 0")
E	Upperstructure width	2,475 (8' 1")
F	Overall height of cab	3,190 (10' 6")
G	Min. ground clearance	340 (1' 1")
H	Tread	1,944 (6' 5")
L	Overall height of guardrail	3,420 (11' 3")

Boom length	5,100 (16' 9") 2-Piece boom	
Arm length	2,200 (7' 3")	2,500 (8' 2")
I	Overall length (Traveling position)	6,580 (21' 7")
I'	Overall length (Shipping position)	8,520 (27' 11")
J	Overall height of boom (Traveling position)	3,990 (13' 1")
J'	Overall height of boom (Shipping position)	3,010 (9' 11")
K	End of attachment to steering wheel	3,310 (10' 10")
		3,330 (10' 11")

HW160 2-PIECE BOOM WORKING RANGE

Unit : mm (ft-in)

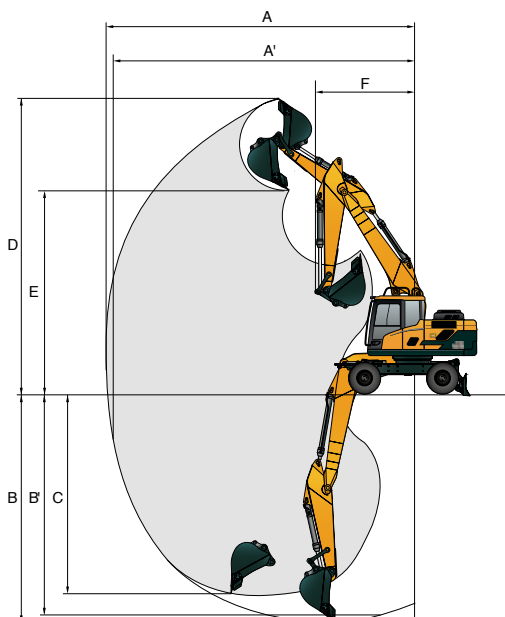

Boom length	5,100 (16' 9") 2-Piece boom	
Arm length	2,200 (7' 3")	2,500 (8' 2")
A	Max. digging reach	8,750 (28' 8")
A'	Max. digging reach on ground	8,540 (28' 0")
B	Max. digging depth	5,220 (17' 2")
B'	Max. digging depth (8' level)	5,100 (16' 9")
C	Max. vertical wall digging depth	4,400 (14' 5")
D	Max. digging height	9,610 (31' 6")
E	Max. dumping height	6,900 (22' 8")
F	Min. front swing radius	3,380 (11' 1")
		3,130 (10' 3")











LIFTING CAPACITY

HW160













 Rating over-front  Rating over-side or 360 degrees

HW160 MONO-BOOM

5.0 m (16' 5") Mono-boom; 2.20 m (7' 3") arm equipped with 0.70 m³ (SAE heaped) bucket and dozer blade down.

Load point height m (ft)	Load radius								At max. reach			
	1.5 m (5 ft)		3.0 m (10 ft)		4.5 m (15 ft)		6.0 m (20 ft)		Capacity		Reach m (ft)	
												
7.5 m (25 ft)	kg								*3360	*3360	5.71	
	lb								*7410	*7410	(18.7)	
6.0 m (20 ft)	kg						*2480	*2480	*3300	2350	7.01	
	lb						*5470	*5470	*7280	5180	(23.0)	
4.5 m (15 ft)	kg				*4220	*4220	*3740	3000	*3340	1910	7.73	
	lb				*9300	*9300	*8250	6610	*7360	4210	(25.4)	
3.0 m (10 ft)	kg				*5340	4530	*4200	2860	*3420	1710	8.07	
	lb				*11770	9990	*9260	6310	*7540	3770	(26.5)	
1.5 m (5 ft)	kg				*6410	4200	*4690	2710	*3510	1670	8.07	
	lb				*14130	9260	*10340	5970	*7740	3680	(26.5)	
Ground Line	kg		*7510	*7510	*6920	4010	*4960	2600	*3590	1770	7.75	
	lb		*16560	*16560	*15260	8840	*10930	5730	*7910	3900	(25.4)	
-1.5 m (-5 ft)	kg	*7150	*7150	*10060	7610	*6740	3960	*4800	2580	*3610	2080	7.04
	lb	*15760	*15760	*22180	16780	*14860	8730	*10580	5690	*7960	4590	(23.1)
-3.0 m (-10 ft)	kg	*10980	*10980	*8310	7790	*5700	4050			*3330	2920	5.78
	lb	*24210	*24210	*18320	17170	*12570	8930			*7340	6440	(19.0)

5.0 m (16' 5") Mono-boom; 2.50 m (8' 2") arm equipped with 0.70 m³ (SAE heaped) bucket and dozer blade down.

Load point height m (ft)	Load radius								At max. reach					
	1.5 m (5 ft)		3.0 m (10 ft)		4.5 m (15 ft)		6.0 m (20 ft)		7.5 m (25 ft)		Capacity		Reach m (ft)	
														
7.5 m (25 ft)	kg										*3140	3030	6.15	
	lb										*6920	6680	(20.2)	
6.0 m (20 ft)	kg						*2460	*2460			*2870	2150	7.35	
	lb						*5420	*5420			*6330	4740	(24.1)	
4.5 m (15 ft)	kg						*3510	3010			*2800	1770	8.04	
	lb						*7740	6640			*6170	3900	(26.4)	
3.0 m (10 ft)	kg			*7720	*7720	*5010	4560	*3990	2860	*1820	*1820	*2860	1590	8.36
	lb			*17020	*17020	*11050	10050	*8800	6310	*4010	*4010	*6310	3510	(27.4)
1.5 m (5 ft)	kg			*7170	*7170	*6160	4190	*4530	2690	*2380	1850	*3040	1540	8.37
	lb			*15810	*15810	*13580	9240	*9990	5930	*5250	4080	*6700	3400	(27.5)
Ground Line	kg			*7640	7490	*6800	3970	*4880	2570			*3380	1630	8.06
	lb			*16840	16510	*14990	8750	*10760	5670			*7450	3590	(26.4)
-1.5 m (-5 ft)	kg	*6610	*6610	*10310	7490	*6770	3900	*4830	2520			*3440	1890	7.38
	lb	*14570	*14570	*22730	16510	*14930	8600	*10650	5560			*7580	4170	(24.2)
-3.0 m (-10 ft)	kg	*9600	*9600	*8780	7640	*5950	3950					*3270	2560	6.20
	lb	*21160	*21160	*19360	16840	*13120	8710					*7210	5640	(20.3)
-4.5 m (-15 ft)	kg			*5610	*5610									
	lb			*12370	*12370									

- Lifting capacity are based on SAE J1097 and ISO 10567.
- Lifting capacity of the HW series does not exceed 75% of tipping load with the machine on firm, level ground or 87% of full hydraulic capacity.

- The load point is a hook (standard equipment) located on the back of the bucket.
- (*) indicates load limited by hydraulic capacity.











LIFTING CAPACITY

HW160











 Rating over-front  Rating over-side or 360 degrees

HW160 2-PIECE BOOM

5.1 m (16' 9") 2-piece boom; 2.20 m (7' 3") arm equipped with 0.70 m³ (SAE heaped) bucket and dozer blade down.

Load point height m (ft)	Load radius								At max. reach		
	3.0 m (10 ft)		4.5 m (15 ft)		6.0 m (20 ft)		7.5 m (25 ft)		Capacity	Reach	
											m (ft)
7.5 m (25 ft)	kg		*3510	*3510					*3250	*3250	5.97
	lb		*7740	*7740					*7170	*7170	(19.6)
6.0 m (20 ft)	kg		*3410	*3410	*3290	*3290			*3180	2420	7.21
	lb		*7520	*7520	*7250	*7250			*7010	5340	(23.7)
4.5 m (15 ft)	kg		*4060	*4060	*3570	3250			*3210	2000	7.91
	lb		*8950	*8950	*7870	7170			*7080	4410	(26.0)
3.0 m (10 ft)	kg		*5170	4880	*4040	3110			*3290	1820	8.24
	lb		*11400	10760	*8910	6860			*7250	4010	(27.0)
1.5 m (5 ft)	kg		*6260	4540	*4560	2960	*2940	2060	*3390	1780	8.25
	lb		*13800	10010	*10050	6530	*6480	4540	*7470	3920	(27.1)
Ground Line	kg		*6840	4370	*4900	2860			*3490	1890	7.93
	lb		*15080	9630	*10800	6310			*7690	4170	(26.0)
-1.5 m (-5 ft)	kg	*9980	8290	*6780	4330	*4850	2830		*3510	2210	7.25
	lb	*22000	18280	*14950	9550	*10690	6240		*7740	4870	(23.8)
-3.0 m (-10 ft)	kg			*5920	4430						
	lb			*13050	9770						

5.1 m (16' 9") 2-piece boom; 2.50 m (8' 6") arm equipped with 0.70 m³ (SAE heaped) bucket and dozer blade down.

Load point height m (ft)	Load radius								At max. reach			
	3.0 m (10 ft)		4.5 m (15 ft)		6.0 m (20 ft)		7.5 m (25 ft)		Capacity	Reach		
											m (ft)	
7.5 m (25 ft)	kg								*3050	3030	6.40	
	lb								*6720	6680	(21.0)	
6.0 m (20 ft)	kg				*2940	*2940			*2900	2220	7.56	
	lb				*6480	*6480			*6390	4890	(24.8)	
4.5 m (15 ft)	kg		*3730	*3730	*3350	3270			*2790	1860	8.23	
	lb		*8220	*8220	*7390	7210			*6150	4100	(27.0)	
3.0 m (10 ft)	kg	*7590	*7590	*4850	*4850	*3840	3110	*2640	2120	*2800	1690	8.54
	lb	*16730	*16730	*10690	*10690	*8470	6860	*5820	4670	*6170	3730	(28.0)
1.5 m (5 ft)	kg		*6000	4540	*4390	2940	*3260	2050	*2920	1650	8.55	
	lb		*13230	10010	*9680	6480	*7190	4520	*6440	3640	(28.1)	
Ground Line	kg	*6440	*6440	*6700	4330	*4790	2820	*2740	2000	*3180	1740	8.25
	lb	*14200	*14200	*14770	9550	*10560	6220	*6040	4410	*7010	3840	(27.1)
-1.5 m (-5 ft)	kg	*9290	8160	*6780	4260	*4850	2780		*3340	2010	7.59	
	lb	*20480	17990	*14950	9390	*10690	6130		*7360	4430	(24.9)	
-3.0 m (-10 ft)	kg			*6130	4330	*4170	2850					
	lb			*13510	9550	*9190	6280					

1. Lifting capacity are based on SAE J1097 and ISO 10567.

2. Lifting capacity of the HW series does not exceed 75% of tipping load with the machine on firm, level ground or 87% of full hydraulic capacity.

3. The load point is a hook (standard equipment) located on the back of the bucket.

4. (*) indicates load limited by hydraulic capacity.

ENGINE	STD	OPT
Cummins QSB 6.7 engine	●	
HYDRAULIC SYSTEM		
Intelligent Power Control (IPC)		
3-power mode, 2-work mode, user mode	●	
Variable Power Control	●	
Pump Flow Control	●	
Attachment Mode Flow Control		●
Engine Auto Idle	●	
Engine Auto Shutdown Control		●
Electronic Fan Control	●	
CABIN & INTERIOR		
ISO Standard cabin		
Rise-up type windshield wiper	●	
Radio / USB player	●	
Handsfree mobile phone system with USB	●	
12 volt power outlet (24V DC to 12V DC converter)	●	
Electric horn	●	
All-weather steel cab with 360° visibility	●	
Safety glass windows	●	
Sliding fold-in front window	●	
Sliding side window (LH)	●	
Lockable door	●	
Hot & cool box	●	
Storage compartment & Ashtray	●	
Transparent cabin roof-cover	●	
Sun visor	●	
Door and cab locks, one key	●	
Mechanical suspension seat with heater	●	
Pilot-operated slidable joystick	●	
Console box height adjust system	●	
Automatic climate control		
Air conditioner & heater	●	
Defroster	●	
Starting Aid (air grid heater) for cold weather	●	
Centralized monitoring		
8" LCD display	●	
Engine speed or Trip meter/Accel.	●	
Engine coolant temperature gauge	●	
Max power	●	
Low speed/High speed	●	
Auto idle	●	
Overload	●	
Check Engine	●	
Air cleaner clogging	●	
Indicators	●	
ECO Gauges	●	
Fuel level gauge	●	
Hyd. oil temperature gauge	●	
Fuel warmer	●	
Warnings	●	
Communication error	●	
Low battery	●	
Clock	●	
Cabin lights		●
Cabin front window rain guard	●	
Cabin roof-steel cover		●
Seat		
Adjustable air suspension seat with heater		●
Cabin FOPS/FOG (ISO/DIS 10262) Level 2		
FOPS (Falling Object Protective Structure) · ISO 3449 Level 2		●
FOG (Falling Object Guard)		●
Cabin ROPS (ISO 12117-2)		
ROPS (Roll Over Protective Structure)	●	

SAFETY	STD	OPT
Battery master switch	●	
Rearview camera	●	
AAVM (Advanced Around View Monitoring)		●
Four front working lights	●	
Travel alarm	●	
Rear work lamp		●
Beacon lamp		●
Automatic swing brake	●	
Boom holding system	●	
Arm holding system	●	
Safety lock valve for boom cylinder with overload warning device	●	
Safety lock valve for arm cylinder		●
Swing Lock System		●
Four outside rearview mirrors	●	
OTHER		
Booms		
5.0 m; 16' 5" Mono	●	
5.1 m; 16' 9.5" 2-Piece		●
Arms		
2.2 m; 7' 3"	●	
2.5 m; 8' 2"		●
Removable clean-out dust net for cooler	●	
Removable reservoir tank	●	
Fuel pre-filter	●	
Fuel warmer	●	
	Single	
	Dual	●
Self-diagnostics system	●	
Hi MATE (Remote Management System)	Mobile	●
	Satellite	●
	Dual	●
Batteries (2 x 12 V x 100 Ah)	●	
Fuel filler pump (50 l/min)		●
Single-acting piping kit (breaker, etc.)		●
Double-acting piping kit (clamshell, etc.)	●	
Rotating Piping Kit		●
Quick coupler piping		●
Quick coupler		●
Accumulator for lowering work equipment	●	
Pattern change valve (2 patterns)		●
Fine Swing Control System		●
Tool kit		●
Auto cruiser system	●	
Travel pedal (2-way)		●
UNDERCARRIAGE		
Rear-dozer blade	●	
Front outrigger and rear blade		●
Front and rear outrigger		●
Front blade and rear outrigger		●
Tires-dual (10.00-20-14PR tube)		●
Tires-dual (10.00-20 solid)		●
Fenders (Mudguards)		●

STD = Standard
OPT = Optional

- * Standard and optional equipment may vary. Contact your Hyundai dealer for more information.
- * The machine may vary according to International standards.
- * The photos may include attachments and optional equipment that are not available in your area.
- * Materials and specifications are subject to change without advance notice.
- * All imperial measurements rounded off to the nearest pound or inch.
- * The air conditioning system on this machine contains the fluorinated greenhouse gas refrigerant HFC-134a (Global Warming Potential = 1430). The system contains 0.65 kg of refrigerant which has a CO₂ equivalent of 0.9295 metric tonne.



PLEASE CONTACT

Hyundai Construction Equipment Europe nv

Hyundailaan 4, 3980 Tessenderlo, Belgium Tel: (32) 14-56-2200 Fax: (32) 14-59-3405 www.hyundai.eu

EN - 2017.11 Rev 5