

DOCUMENTATION

Project : Pipe Heat Trace Martin Linge PO
4590294126

Company : Equinor Energy

Project No. : 2101292

Z	26.11,21	As Built	TIS	TIS	TG		
Rev. No.	Date	Description	Prepared	Checked	Approved		
			ORIGINATOR			COMPANY	



DOCUMENT TITLE:

Final Documentation

DOCUMENT NUMBER:

1. Declaration of Conformity
2. Drawing
3. Datasheets
4. EX certificates



SAMSVARERKLÆRING / DECLARATION OF CONFORMITY

MARITIME ENERGY SERVICE AS

Referansenr / Reference no: 2101292

<input checked="" type="checkbox"/> Erklæringen omfatter Prosjektering / Declaration Include engineering.	<input checked="" type="checkbox"/> Erklæringen omfatter utførelse / Declaration Include installation.
Utført av / Performed by: Maritime Energy Services AS	Telefon / Telephone: +47 948 08 020
Adresse / Address: Røynebergsletta 29, 4033 Stavanger	
Eiers navn – Adresse / Owners name – address: Equinor Energy, P.O. Box 8500, 4035 Stavanger, Norway	
Anleggsbeskrivelse / System Description: Pipe Heat Trace Martin Linge	
Lokasjon / Location: Stavanger	Kjenningbokstaver / Identification: Pipe Heat Trace Martin Linge PO 4590294126

Anvendte normer / Used Standards:

- **FEL:** Forskrift om elektriske lavspenningsanlegg / *Norwegian electrical regulations for low voltage plants.*
- **NEK 400:** Elektriske lavspenningsanlegg-installasjoner. Bearbeidet oversettelse av CENELEC HD384 & IEC 60363. (Relevante bestemmelser) / *Low voltage plants-installations. Edited translation of CENELEC HD 384 and IEC 60363. (Relevant regulations)*
- **NEK 410:** Maritime elektriske anlegg / *Norwegian regulations for maritime electrical installations*
- **NEK 420:** Elektriske anlegg i eksplosjonsfarlige områder av gass & støv. / *Norwegian regulations for hazardous areas containing gas or dust.*
- **IEC EN 60079 series**
- **IEC 61892**

Merknader / Notes:

- Når det gjelder NEK400 vil relevante bestemmelser for bruk i maritime anlegg kunne være beskrivelse av fordelingssystemer, installasjoner i innredning slik som lugarer, baderom osv, svømmebasseng, termiske anlegg osv. / Regarding NEK400, relevant regulations for use in maritime installations might be power distribution systems, living quarters etc.
- IEC 60092-serien er oversatt til norsk gjennom NEK 410 Norske normer for maritime elektriske anlegg- installasjoner og utstyr om bord i skip. Ved uoverensstemmelser mellom IEC 60092-serien og NEK 410 er det IEC 60092-serien som gjelder. / NEK 410 includes a norwegian translation of IEC 60092-series. If it is divergence between the norms, IEC 60092 is prevailing.
- Direktoratet for brann- og el.sikkerhet har i vedlegg II til denne forskrift laget nødvendige tillegg som kan legges til grunn ved anvendelse av IEC 60092-serien. / Directorate for Fire & Electrical safety has in attachment II to NEK 410, made the necessary supplements to be used as base for IEC 60092-series applications.
- «Norm» og «standard» er synonyme begreper / «Norm» and «standard» are synonymous terms.

Undertegnede erklærer at anleggets prosjektering og/eller utførelse er i henhold til ovenfor nevnte standard & normer.
The signature declare that the system is engineered and/or installed according to the norms & standards listed above.



Blokkbokstaver / Block letters

26.11.21 Stavanger

Sted-dato / Place-date

Jens Arne Thorsen

Fagansvarlig / Discipline Responsible

Tom Inge Sporkland

Prosjektleder / Project Manager

Stempel / Stamp

Jens Arne Thorsen

Signatur / Signature



Tom Inge Sporkland

Signatur / Signature

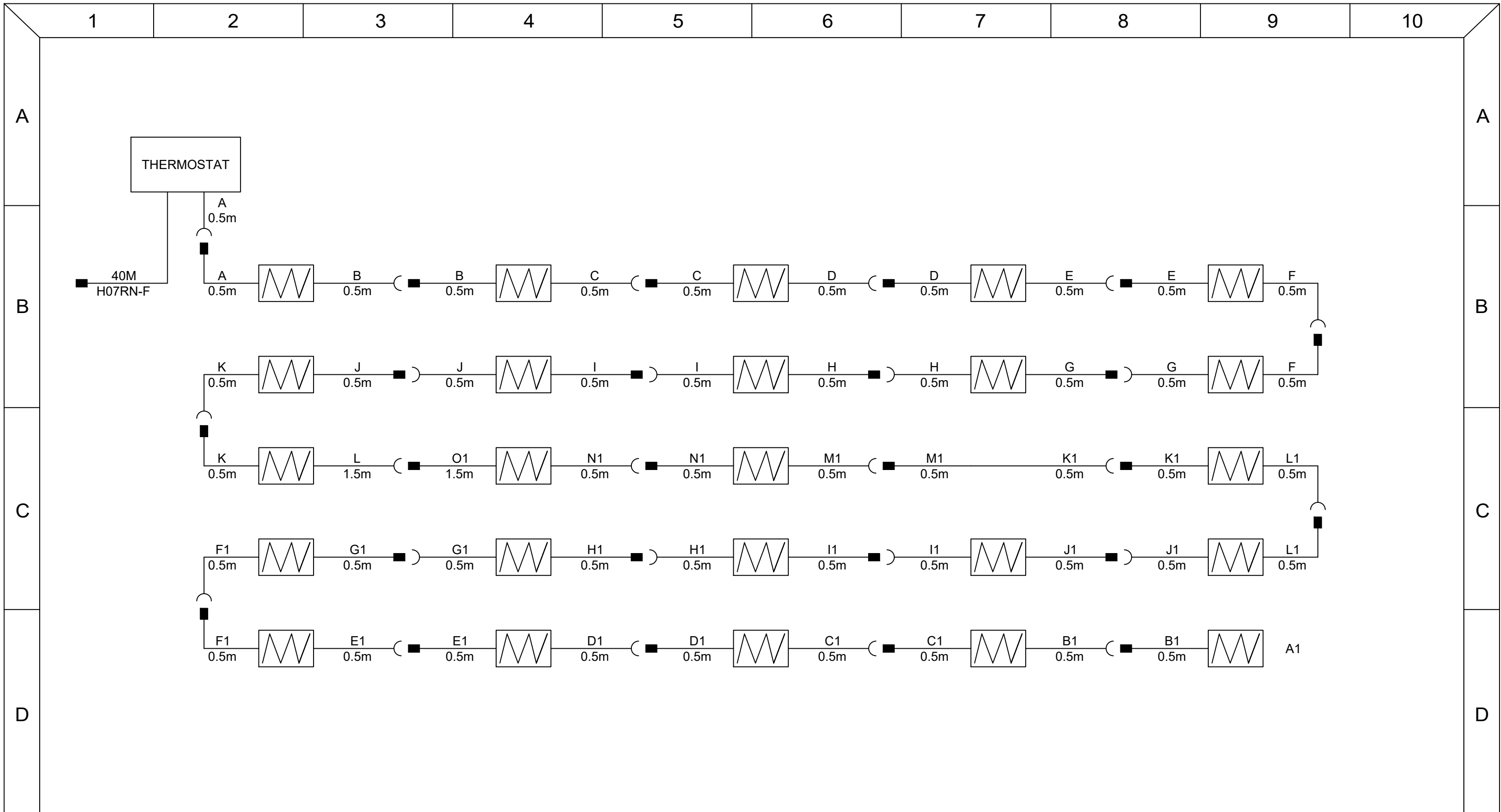

Maritime Energy Service AS

Røynebergsletta 29, P.O.Box 138, N-4033 Stavanger, Norway - Tel. +47 94808020 - Org. No.: 919 508 833

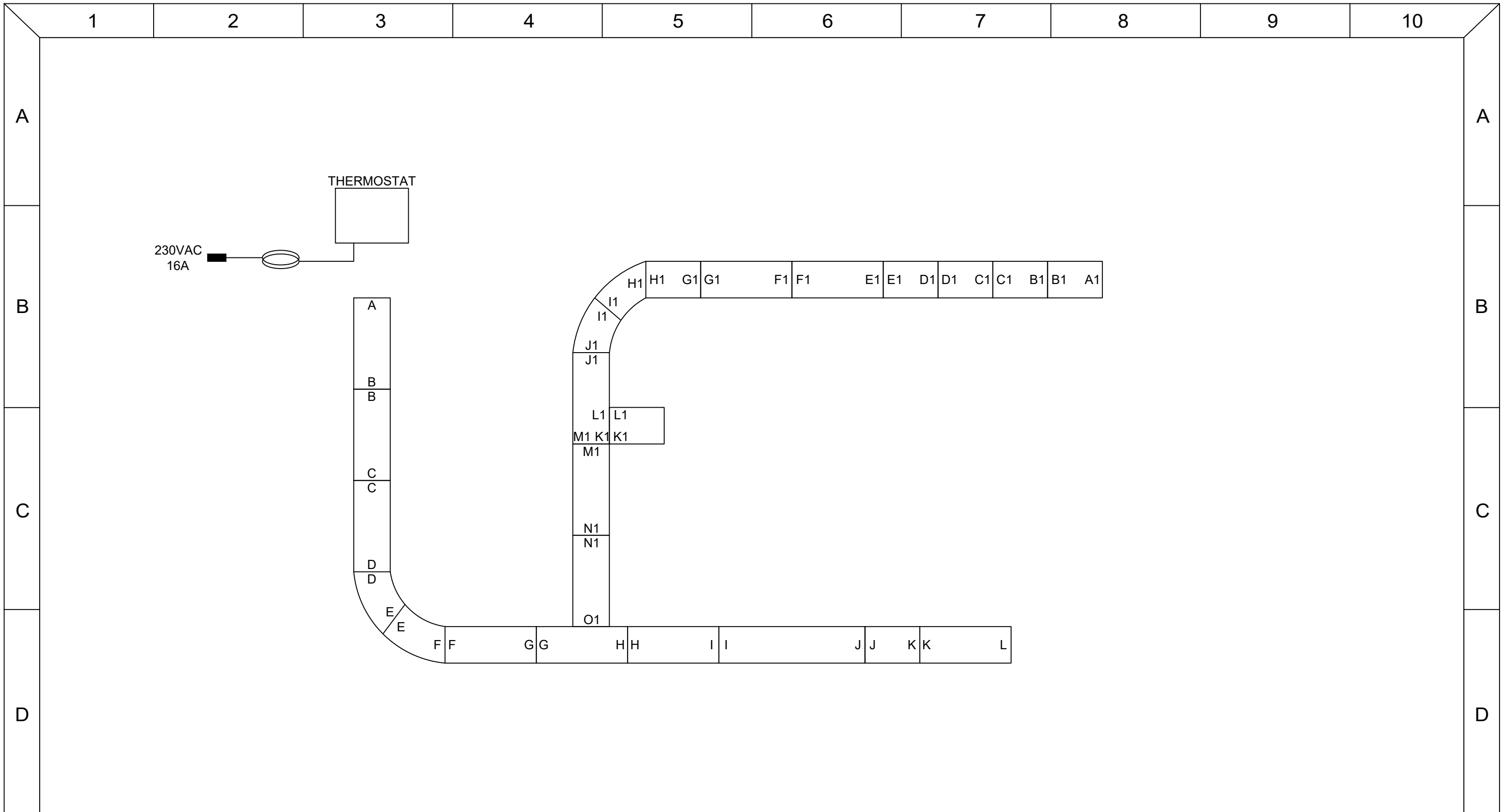

AUTOCAD	NOTES:						CUSTOMER: EQUINOR	 MARITIME ENERGY SERVICE WWW.MESAS.NO			
							UNIT ID:				TITLE: HEAT BLANKETS
							CLIENT REF:	DESCRIPTION: MARTIN LINGE BLOCK DIAGRAM			
	A	AS BUILT			EV	DB	20211206	TIS	SIZE A		DWG. NO. MES2101292-EXI-001
	REV	DESCRIPTION			DRAWN	CHKD	DATE	APVD	PROJECT NO.: 2101292		
1	2	3	4	5	6	7	8	9	SHEET 1 OF 1		
1	2	3	4	5	6	7	8	9	10		



AUTOCAD	NOTES:						CUSTOMER: EQUINOR	 MARITIME ENERGY SERVICE WWW.MESAS.NO	TITLE: HEAT BLANKETS			
							UNIT ID:			DESCRIPTION: MARTIN LINGE LAYOUT DRAWING		
							CLIENT REF:			SIZE A	DWG. NO. MES2101292-EXE-001	REV. A
	A	AS BUILT			EV	DB	20211206			TIS	THIS DRAWING IS THE PROPERTY OF MES AS AND IS CONFIDENTIAL, IT IS NOT ALLOWED TO COPY OR SHOW TO THIRD PARTIES WITHOUT PERMISSION FROM MES AS.	
	REV	DESCRIPTION			DRAWN	CHKD	DATE		APVD	PROJECT NO.: 2101292	SHEET 1 OF 1	

Self-regulating Heating Cable

HEATING CABLE CONSTRUCTION

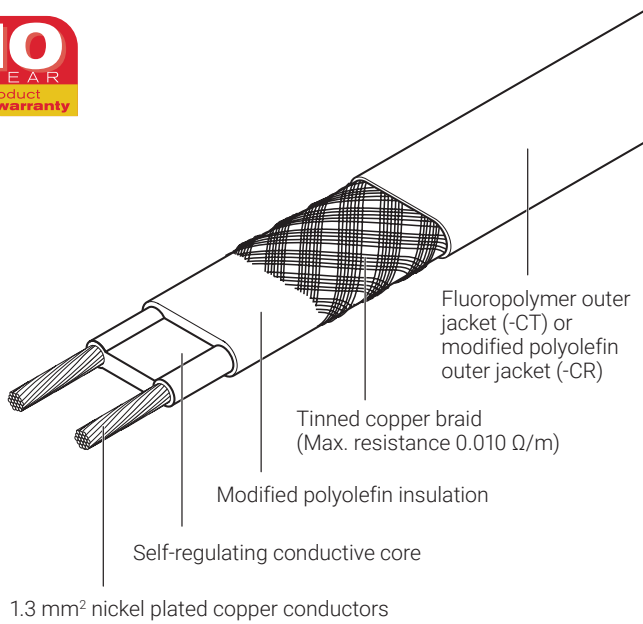

Electrical heat-tracing for frost protection without steam cleaning. The nVent RAYCHEM BTV-family of self-regulating, parallel circuit heating cables is used for frost protection of pipes and vessels. It can also be used for process temperature maintenance up to 65°C.

APPLICATION

Area classification	Hazardous, Zone 1, Zone 2 (Gas), Zone 21, Zone 22 (Dust) Ordinary
Traced surface type	Carbon steel Stainless steel Plastic Painted or unpainted metal
Chemical resistance	For organic corrosives: use -CT (fluoropolymer outer jacket) For mild inorganic solutions: use -CR (modified polyolefin outer jacket) For aggressive organics and corrosives consult your local nVent representative

SUPPLY VOLTAGE

230 Vac (Contact your local nVent representative for data on other voltages)

APPROVALS*

SGS20ATEX0048X

II 2 G Ex 60079-30-1 eb IIC T6 Gb or Ex 60079-30-1 eb mb IIC T6 Gb

II 2 G Ex 60079-30-1 tb IIIC T80°C or Ex 60079-30-1 mb tb IIIC T80°C

Tmin -60°C

IECEx BAS 20.0011X

Ex 60079-30-1 eb IIC T6 Gb or Ex 60079-30-1 eb mb IIC T6 Gb

Ex 60079-30-1 tb IIIC T80°C or Ex 60079-30-1 mb tb IIIC T80°C

Tmin -60°C

The BTV heating cables are approved by DNV for use on ships and mobile offshore units.

DNV Certificate No. DNV-GL TAE00000TU



TC RU C-BE.MЮ62.B.00054/18

1Ex e IIC T6 Gb X 1Ex e mb II C T6 Gb X

Ex tb IIIC T80°C Db X Ex tb mb IIIC T80°C Db X

Ta -60°C...+56°C IP66

ООО "ТехИмпорт"



Ex e IIC T6 Gb

Ex tD A21 IP66 T80°C

SPECIFICATIONS

Maximum maintain or continuous exposure temperature (power on/off)	65°C
Maximum intermittent exposure temperature (power on/off)	85°C Maximum cumulative exposure 1000 hours
Temperature classification	T6
Minimum installation temperature	-60°C
Minimum bend radius	-60°C ≤ T < -20°C: 35 mm -20°C ≤ T < -10°C: 30 mm -10°C ≤ T < 0°C: 25 mm 0°C ≤ T < +10°C: 20 mm T ≥ +10°C: 12 mm

THERMAL OUTPUT RATING

Nominal power output at 230 Vac on insulated steel pipes

- A 10BTV2-CT**
10BTV2-CR
- B 8BTV2-CT**
8BTV2-CR
- C 5BTV2-CT**
5BTV2-CR
- D 3BTV2-CT**
3BTV2-CR

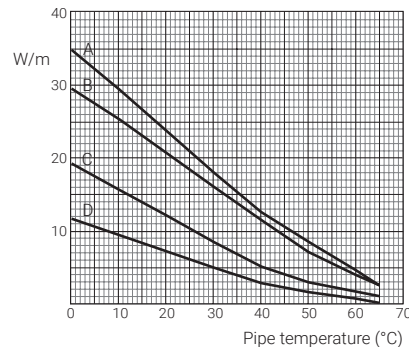

	3BTV2-CR 3BTV2-CT	5BTV2-CR 5BTV2-CT	8BTV2-CR 8BTV2-CT	10BTV2-CR 10BTV2-CT
Nominal power output (W/m at 10°C)	9	16	25	29

PRODUCT DIMENSIONS (NOMINAL) AND WEIGHT

	3BTV2-CR 3BTV2-CT	5BTV2-CR 5BTV2-CT	8BTV2-CR 8BTV2-CT	10BTV2-CR 10BTV2-CT
Thickness (mm)	5.5	5.5	5.5	5.5
Width (mm)	10.5	10.5	15.4	15.4
Weight (g/m)	110	110	153	153

MAXIMUM CIRCUIT LENGTH BASED ON TYPE 'C' CIRCUIT BREAKERS ACCORDING TO EN 60898

Electrical protection sizing	Start-up temperature	Maximum heating cable length per circuit (m)			
		16 A	20 A	25 A	32 A
16 A	-20°C	155	110	70	45
	+10°C	200	160	110	65
20 A	-20°C	195	140	90	55
	+10°C	200	160	125	85
25 A	-20°C	200	160	110	70
	+10°C	200	160	125	105
32 A	-20°C	200	160	125	90
	+10°C	200	160	125	110

The above numbers are for circuit length estimation only. For more detailed information please use the nVent RAYCHEM TraceCalc software or Contact your local nVent representative. nVent requires the use of a 30 mA residual current device to provide maximum safety and protection from fire. Where design results in higher leakage current, the preferred trip level for adjustable devices is 30 mA above any inherent capacitive leakage characteristic of the heater as specified by the trace heater supplier or alternatively, the next common available trip level for non adjustable devices, with a maximum of 300 mA. All safety aspects need to be proven.

ORDERING DETAILS

Part description	3BTV2-CR	5BTV2-CR	8BTV-2-CR	10BTV2-CR
Part No. (*)	914279-000	414809-000	479821-000	677245-000
Part description	3BTV2-CT	5BTV2-CT	8BTV-2-CT	10BTV2-CT
Part No. (*)	469145-000	487509-000	008633-000	567513-000

COMPONENTS

nVent offers a full range of components for power connections, splices and end seals. These components must be used to ensure proper functioning of the product and compliance with electrical requirements.

(*) Localized versions may exist with limited approvals and different part numbers. Contact your local sales representative

North America

Tel +1.800.545.6258
 Fax +1.800.527.5703
thermal.info@nVent.com

Europe, Middle East, Africa

Tel +32.16.213.502
 Fax +32.16.213.604
thermal.info@nVent.com

Asia Pacific

Tel +86.21.2412.1688
 Fax +86.21.5426.3167
cn.thermal.info@nVent.com

Latin America

Tel +1.713.868.4800
 Fax +1.713.868.2333
thermal.info@nVent.com



Our powerful portfolio of brands:

CADDY ERICO HOFFMAN RAYCHEM SCHROFF TRACER

TRANBERG® THERMOSTAT

Type 1058 Capillary Tube Thermostat, Wall Mounted

Zone 1, Zone 2 & Safe Area



Tranberg heat trace boxes are represented in most of the oil installations in the North Sea, and also petrochemical industries and other industries subjected to rough environments.

Application

- Hazardous areas
- Chemical and petrochemical industries
- Industrial plants (for frost protection or temperature maintenance)
- According to NORSOK requirements

Features and benefits

- High ingress protection. IP66/67 is standard, IP 67 without drain plug.
- Manufactured in acid proof stainless steel (AISI 316L)
- Stainless steel type label spot welded to the cover.
- Several earthing alternatives.
- Maximum strength and corrosion resistance.
- High operational reliability.
- Low lifetime maintenance cost.
- Recommended for up to 4 heating cables.

Equipped with

- 8 pc. M25 stopping plugs in box
- 1 pc. cable gland Type: E204/622 M25/D9, packed inside JB.
- 1 pc. drain plug M25 packed inside JB.
- Connections for up two power cables.
- 1 pc. label kit, packed inside JB. (9090 025)

Approvals and certificates

ATEX: Presafe 14ATEX4124

IECEX: IECEX PRE 14.0001

R. Stahl Tranberg has designed and manufactured heat tracing equipment and heating applications for rough environments for more than 25 years.

Our product range includes therefore a number of different heat tracing junction boxes.

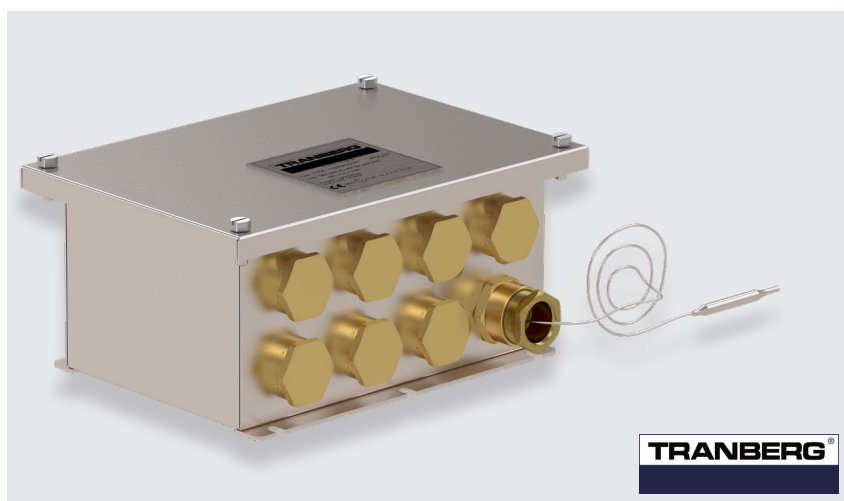

Technical Data

Water Ingress Protection:	IP66 / IP67 (without drain plug)
Material:	AISI 316L / EN 1.4404
Finish:	Electro polished
Capillary tube length:	1m
Capillary tube diam.:	6/1,5 mm
El. Contact:	1 change-over switch
Max. switching capacity N/C contact (L-2):	16 (2.5) A, cos φ = 1 (0.6) 230VAC
Max. switching capacity N/C contact (L-4):	2 (0.4) A, cos φ = 1 (0.6) 230VAC
Max. wire termination (with end sleeve):	Power in: Max. 6mm ² Heating cable (power out): Max. 4mm ² Earth terminals: Max. 10mm ²
Tamb (Operation):	-50°C to +50°C
Hysteresis:	Approx. 7% of measurement range

TRANBERG STAHL

THE STRONGEST LINK.

R. STAHL TRANBERG AS

Main office | Strandsvingen 6 | N-4032 Stavanger, Norway | T +47 51 57 89 00 | E info.no-st@r-stahl.com | stahl-tranberg.com
Oslo office | Luhltoppen 2 | N-1470 Lørenskog, Norway | T +47 24 08 44 10 | E info.no-os@r-stahl.com | stahl-tranberg.com

TRANBERG® THERMOSTAT

Type 1058 Capillary Tube Thermostat, Wall Mounted

Zone 1, Zone 2 & Safe Area

Description	Approx. Weight	EL no.	EAN no.	Part No.
Temperature setting -20°C to +50°C	4,5 kg	54 000 55	7070937045293	10582580
Temperature setting 0°C to +120°C	4,5 kg	54 000 56	7070937045309	10582581
Temperature setting 0°C to +200°C	4,5 kg	54 000 57	7070937045316	10582582
Temperature setting +50°C to +300°C	4,5 kg	54 000 58	7070937045323	10582583

Description Accessories	Weight	Part No.
Connection kit Wall Mounting for Raychem Cables: 3BTV-5BTV-10QTVR-15QTVR-XTV-VPL-HTV 5x11 - w/Termination kit C25-21 - HOT	0,53 kg.	9179224
Connection kit Wall Mounting for Raychem Cables: 8BTV-10BTV-20QTVR-KTV 5x15 - w/Termination kit C25-21 - HOT	0,53 kg.	9179204
Connection kit Wall Mounting 5x11/5x15 M28x1 HOT for all Raychem Cables	0,53 kg.	9179220
Connection kit Wall Mounting for Raychem Cables: 3BTV-5BTV-10QTVR-15QTVR-XTV-VPL-HTV 5x11 - w/Termination kit - C25-100 - COLD	0,53 kg.	9179226
Connection kit Wall Mounting for Raychem Cables: 8BTV-10BTV-20QTVR-KTV 5x15 - w/Termination kit C25-100 - COLD	0,53 kg.	9179206
Connection kit Wall Mounting 5x11/5x15 M28x1 COLD for all Raychem Cables	0,53 kg.	9179227
Flexible hose SS316. Inner diam. 18,8mm, outer diam.: 22,3mm. Length : 2 meter	0,5 kg.	7000080
Flexible hose SS316. Inner diam. 18,8mm, outer diam.: 22,3mm. Length : 25 meter	6,2 kg.	7000081
Adapter for flexible hose M28x1		50791123
Cable Gland Exe: E204/622 M25/D9/9mm (Ø13,0-17,0mm), w/ lock nut	0,1 kg.	6222532
Cable Gland Exe: E204/622 M25/D1/9mm (Ø15,0-20,1mm), w/ lock nut	0,1 kg.	6222512



R. STAHL TRANBERG AS

Main office | Strandsvingen 6 | N-4032 Stavanger, Norway | T +47 51 57 89 00 | E info.no-st@r-stahl.com | stahl-tranberg.com

Oslo office | Lührtoppen 2 | N-1470 Lørenskog, Norway | T +47 24 08 44 10 | E info.no-os@r-stahl.com | stahl-tranberg.com

TRANBERG® THERMOSTAT

Type 1058 Capillary Tube Thermostat, Wall Mounted

Zone 1, Zone 2 & Safe Area

Dimensions

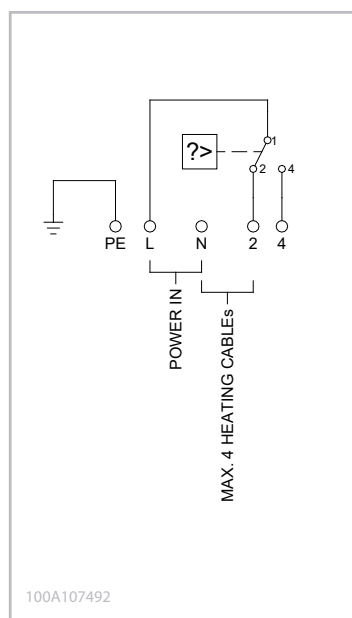
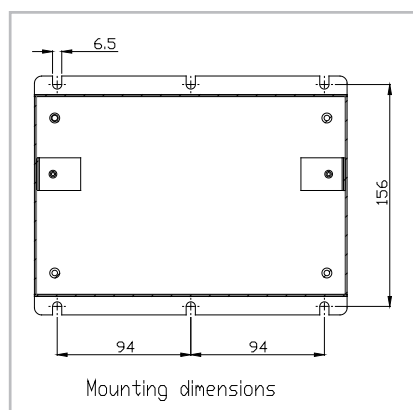
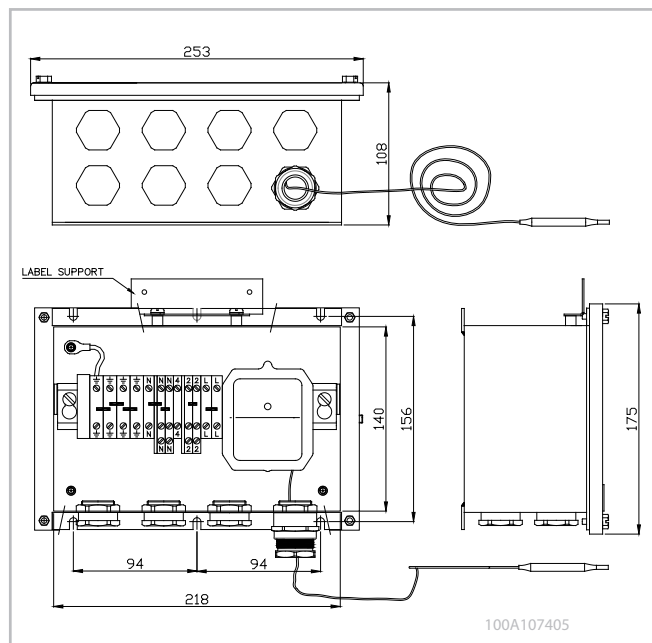

Ex-plugs and receptacles 16 A 3/4/5-pole up to 690 V

1



Wall socket



Flange socket



Coupler



Plug

Technical data

Ex-plugs and receptacles acc. to IEC 60309-1/2 16A

Marking accd. to 2014/34/EU	Wall socket, plug and coupler: $\text{II 2 G Ex ed IIC T6} / \text{II 2 D Ex tD A21 IP66 T80 } ^\circ\text{C}$ Flange socket: $\text{II 2 G Ex db eb IIC/IIB Gb} / \text{II 2 D Ex tb IIIC Db}$
EC-Type Examination Certificate	Wall socket, plug and coupler: PTB 99 ATEX 1039 / Flange socket: BVS 15 ATEX E 101 U
IECEx Certificate of Conformity	Wall socket, plug and coupler: IECEx BKI 04.0002 / Flange socket: IECEx BVS 15.0088U
Marking accd. to IECEx	Wall socket, plug and coupler: IEx ed [ia] IIC T6/T5 / Flange socket: Ex db eb IIC/IIB Gb / Ex tb IIIC Db
Permissible ambient temperature	-20°C up to +40°C ¹⁾
Rated voltage	up to 400 V, (3-pole) / 690 V, (4-pole) / 500 V, (5-pole) AC
Rated current	16 A
Frequency	up to 400 Hz
Rated making / Rated breaking capacity AC-3 accd. EN 60947-3	U _e 250 V / I _e 16 A (3-pole) U _e 690 V / I _e 16 A (4-pole) U _e 500 V / I _e 16 A (5-pole)
External back-up fuse, max.	without therm. protection: 16 A with therm. protection: 35 A gG (rated current 16 A set to)
Protection class	I
Degree of protection accd. to EN 60529	IP66

Wall socket

Cable entry	1 x M25 cable gland, 1 x M25 plastic Ex-screw plug or 2 x metal thread M20 with plastic Ex-screw plug
Connecting terminals	2 x 1 - 4 mm ²
Enclosure material	glass-fibre reinforced polyester

Plug

Cable entry	Ø 8 - 19 mm (3-pole) / Ø 8 - 21 mm (4-pole) / 12 - 21 mm (5-pole)
Connecting terminals	1 x 1.0 - 2.5 mm ²
Enclosure material	Polyamide

Coupler

Cable entry	Ø 8 - 19 mm (3-pole) / Ø 8 - 21 mm (4-pole) / 12 - 21 mm (5-pole)
Connecting terminals	2 x 1 - 4 mm ²
Enclosure material	Polyamide

Flange socket

Connecting terminals	2 x 1 - 4 mm ²
Enclosure material	Polyamide

¹⁾ extended temperature range on request.

Details for used cable glands see pages 2.3.ff

Ordering details

Voltage	h	Type	Aux. contact	Cable entry	Weight approx.	Order No.
110-130 V	 <p>4 h</p>	Wall socket	–	M25 KU	1.2 kg	GHG 511 4304 R0001
		Wall socket	–	M20 GE	1.2 kg	GHG 511 4304 R0002
		Wall socket	–	M20 ME	1.3 kg	GHG 511 4304 R3001
		Wall socket	–	M20 GM	1.3 kg	GHG 511 4304 R3003
		Flange socket	–		0.4 kg	GHG 511 8304 R0001
		Coupler	–		0.7 kg	GHG 511 3304 R0001
		Plug	–		0.35 kg	GHG 511 7304 R0001

Ex-plugs and receptacles 16 A 3/4/5-pole up to 690 V



Plug



Coupler









Flange socket



Wall socket

Ordering details

Voltage	h	Type	Aux. contact	Cable entry	Weight approx.	Order No.
Type 16 A 3-pole						
200-250 V		Wall socket	–	KU	1.2 kg	GHG 511 4306 R0001
		Wall socket	–	GE	1.2 kg	GHG 511 4306 R0002
		Wall socket	–	ME	1.3 kg	GHG 511 4306 R3001
		Wall socket	–	GM	1.3 kg	GHG 511 4306 R3003
		Flange socket			0.4 kg	GHG 511 8306 R0001
		Coupler			0.7 kg	GHG 511 3306 R0001
		Plug			0.35 kg	GHG 511 7306 R0001
Type 16 A 4-pole						
200-250 V		Wall socket	–	KU	1.4 kg	GHG 511 4409 R0001
		Wall socket	–	ME	1.5 kg	GHG 511 4409 R3001
		Wall socket	–	GM	1.6 kg	GHG 511 4409 R3003
		Flange socket			1.0 kg	GHG 511 8409 R0001
		Coupler			0.9 kg	GHG 511 3409 R0001
		Plug			0.38 kg	GHG 511 7409 R0001
		380-415 V		Wall socket	–	KU
Wall socket	–			ME	1.5 kg	GHG 511 4406 R3001
Wall socket	–			GM	1.6 kg	GHG 511 4406 R3003
Wall socket	yes			KH	1.4 kg	GHG 511 4406 R0501
Flange socket					1.0 kg	GHG 511 8406 R0001
Coupler					0.9 kg	GHG 511 3406 R0001
Plug					0.38 kg	GHG 511 7406 R0001
480-500 V		Wall socket	–	KU	1.4 kg	GHG 511 4407 R0001
		Wall socket	–	ME	1.5 kg	GHG 511 4407 R3001
		Wall socket	yes	KH	1.4 kg	GHG 511 4407 R0501
		Flange socket			1.0 kg	GHG 511 8407 R0001
		Coupler			0.9 kg	GHG 511 3407 R0001
		Plug			0.38 kg	GHG 511 7407 R0001
		600-690 V		Wall socket	–	KU
Wall socket	–			ME	1.5 kg	GHG 511 4405 R3001
Wall socket	yes			KH	1.4 kg	GHG 511 4405 R0501
Flange socket					1.0 kg	GHG 511 8405 R0001
Coupler					0.9 kg	GHG 511 3405 R0001
Plug					0.38 kg	GHG 511 7405 R0001
Type 16 A 5-pole						
200-250 V 380-415 V		Wall socket	–	KU	1.4 kg	GHG 511 4506 R0001
		Wall socket	–	ME	1.5 kg	GHG 511 4506 R3001
		Wall socket	yes	KH	1.4 kg	GHG 511 4506 R0501
		Wall socket	–	GM	1.6 kg	GHG 511 4506 R3003
		Flange socket			1.0 kg	GHG 511 8506 R0001
		Coupler			0.95 kg	GHG 511 3506 R0001
		Plug			0.42 kg	GHG 511 7506 R0001

Other voltage ranges and versions available on request

KU = 1 x plastic cable glands M25, 1 x M25 plastic Ex-screw plug

ME = 2 x metal thread M20

GM = 2 x metal thread M20 with screw plug, with external earth bolt M6

KH = 2 x plastic cable glands M25, aux. contact, 1 NO

GE = 2x plastic thread M20 without gland/screw plug

Ex-plugs and receptacles 16 A 3/4/5-pole up to 690 V

1



Wall socket



flange socket



Coupler



Plug

Dimension drawing | Wiring diagram

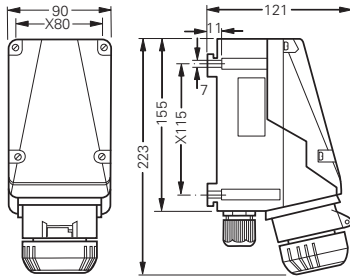

Wall socket 3-pole

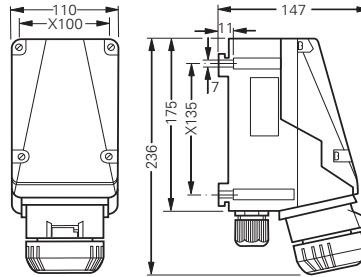

Wall socket 4/5-pole

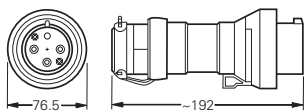

Plug 3-pole

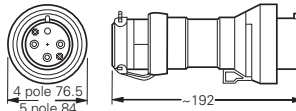

Plug 4/5-pole

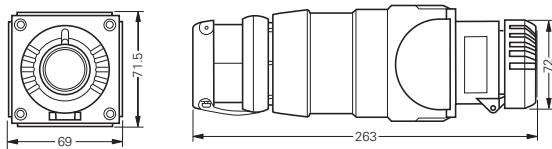

Coupler 3-pole

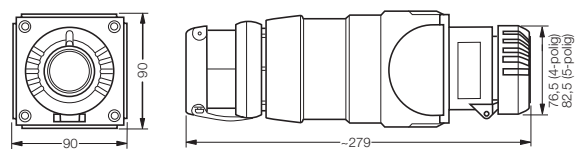

Coupler 4/5-pole

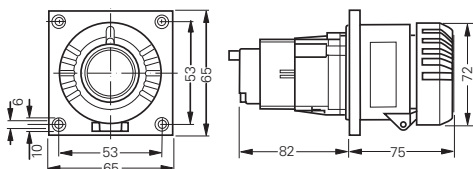

Flange socket 3-pole

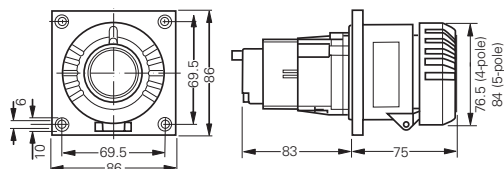

Flange socket 4/5-pole

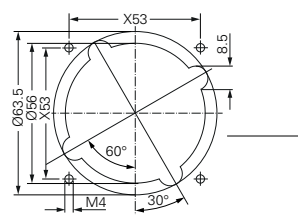

Assembly dimensions flange socket

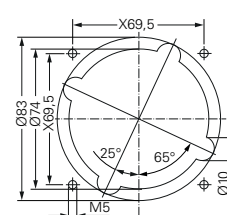

Assembly dimensions flange socket X = fixing dimensions

without aux. contact

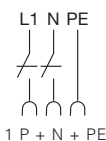

without aux. contact

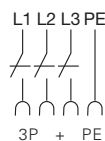

with aux. contact

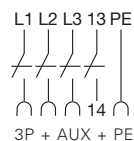

without aux. contact

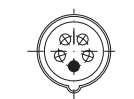
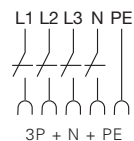

with aux. contact

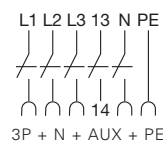



Protective canopy



Plug cap



GHG 610 1901 R0126

Accessories

Type	Application	Fixing method	Order No.
Mounting plates for wall sockets 16 A			
Size 4	for wall mounting	snap on	GHG 610 1953 R0126
Size 4	for trellis mounting	snap on	GHG 610 1953 R0126
Size 4	for pipe clamp	snap on	GHG 610 1953 R0130
Type			Order No.
Plug cap for plugs 16 A			
Plug 16 A 3-pole			GHG 510 1901 R0001
Plug 16 A 4-pole			GHG 510 1901 R0002
Plug 16 A 5-pole			GHG 510 1901 R0003
Type		OU	Order No.
Accessories for mounting plates			
Mounting set for pipes 1" (Ø 27 - 30 mm) for mounting plates with pipe fixing		10	GHG 610 1953 R0020
Please pay attention that only order units (OU) according to the ordering details can be delivered.			
Type		Application	Order No.
Protective canopy for mounting plate			
Size 4	for mounting plate size 4, snap on		GHG 610 1955 R0107

Dimension drawing

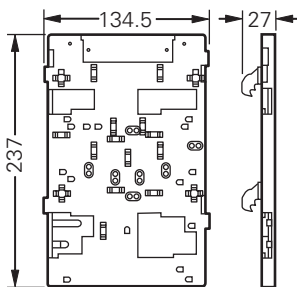

Mounting plate size 4 for wall/trellis mounting

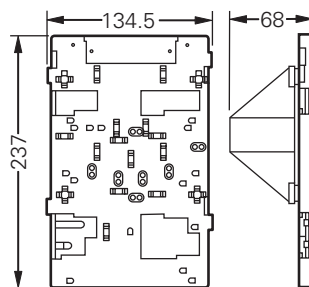

Mounting plate size 4 for pipe clamp

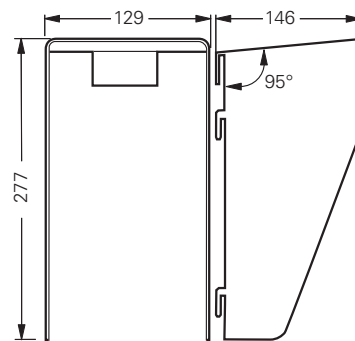

Protective canopy size 4

EU - TYPE EXAMINATION CERTIFICATE

Equipment or Protective System Intended for use in Potentially Explosive Atmospheres Directive 2014/34/EU

- 1 EU - Type Examination Certificate Number: **SGS20ATEX0048X – Issue 2**
- 2 Product: **BTV Range of Self-Regulating Trace Heating Systems**
- 3 Manufacturer: **nVent Thermal LLC**
- 4 Address: **899 Broadway Street, CA, 94063-3104, United States of America**
- 5 This re-issued certificate extends EU Type Examination Certificate No. **SGS20ATEX0048X** to apply to product designed and constructed in accordance with the specification set out in the Schedule of the said certificate but having any variations specified in the Schedule attached to this certificate and the documents therein referred to.
- 6 SGS Fimko Oy, Notified Body number 0598, in accordance with Article 17 of Directive 2014/34/EU of the European Parliament and of the Council, dated 26 February 2014, certifies that this product has been found to comply with the Essential Health and Safety Requirements relating to the design and construction of products intended for use in potentially explosive atmospheres given in Annex II to the Directive.
- 7 The examination and test results are recorded in confidential Report No. See Certificate History
- 8 Compliance with the Essential Health and Safety Requirements has been assured by compliance with:
**EN IEC 60079-0:2018 EN IEC 60079-7:2015+A1:2018 EN 60079-18:2015+A1:2017
EN 60079-30-1:2017 EN 60079-31:2014**
- 9 in respect of those requirements listed at item 18 of the Schedule.
- 10 If the sign “X” is placed after the certificate number, it indicates that the product is subject to the Specific Conditions of Use specified in the schedule to this certificate.
- 11 This EU - TYPE EXAMINATION CERTIFICATE relates only to the design and construction of the specified product. Further requirements of the Directive apply to the manufacturing process and supply of this product. These are not covered by this certificate.
- 12 The marking of the product shall include the following :
- ⊕ II 2 GD Ex 60079-30-1 eb IIC T6 Gb or Ex 60079-30-1 eb mb IIC T6 Gb T_{min} -60°C
Ex 60079-30-1 tb IIC T80°C Db or Ex 60079-30-1 mb tb IIC T80°C Db**

SGS Fimko Oy Customer Reference No. **865**

Project File No. **21/0234**

This document is issued by the Company subject to their General Conditions for Certification Services accessible at <http://www.sgs.com/en/Terms-and-Conditions.aspx>. Attention is drawn to the limitation of liability, indemnification and jurisdiction issues defined therein. Any holder of this document is advised that information contained herein reflects the Company's findings at the time of their intervention only and within the limits of Client's instructions, if any. It does not necessarily indicate that the equipment may be used in particular industries or circumstances. The Company's sole responsibility is to its Client and this document does not exonerate parties to a transaction from exercising all their rights and obligations under the transaction documents. This document cannot be reproduced except in full, schedule included, without prior written approval of the Company. Any unauthorized alteration, forgery or falsification of the content or appearance of this document is unlawful and offenders may be prosecuted to the fullest extent of the law.

SGS Fimko Oy

Takomotie 8
FI-00380 Helsinki, Finland
Telephone +358 (0)9 696 361
e-mail sgs.fimko@sgs.com
web site www.sgs.fi

Business ID 0978538-5 Member of the SGS Group (SGA SA)



Tuomas Hänninen
SGS Fimko Oy

13

Schedule

14

Certificate Number SGS20ATEX0048X – Issue 2

15 Description of Product

The BTV Range of Self-Regulating Trace Heating Systems is of the parallel circuit self-regulating type, rated at up to 277V, with power output up to 33W/m (10W/ft). The units have a maximum self-limiting temperature of 80°C.

Each trace heating system comprises:

- the active heating cable.
- an end seal for terminating the remote end of the unit.
- a cable gland for connecting the powered end of the unit to a suitable terminal enclosure, or alternative integrated power connection systems.

The active heating cable comprises two stranded copper conductors around which is extruded a semi-conductive core material. This core material increases in resistance with increasing temperature and gives the cable its self-limiting property. This semi conductive core with embedded conductors forms the active part of the heating cable. An extruded layer of fluoropolymer serves to insulate the semi conductive core from the conductive covering, covering the active heater. A protective anti-corrosion fluoropolymer sheath may be extruded over the conductive covering.

The declared maximum withstand temperature for the range is 85°C and the minimum installation temperature is -60°C.

CABLE ACCESSORIES

END SEALS

The end seals for terminating the remote end of the unit may be the following types:

Types E-100-L or E-100, which are mechanical end seals incorporating an end cap which is filled with silicone grease sealant covered by certificates Sira14ATEX3015X and PTB09ATEX1060U.

Types E-100-L-A or E-100-A, which are mechanical end seals incorporating an end cap which is filled with silicone grease sealant.

A Raychem Type E-20 heat shrink end seal kit.

Type E-150 mechanical end seals, covered by certificate DEKRA20ATEX0011U.

SPLICES AND JOINTS

The following splicing and jointing arrangements are provided:

A Raychem Type S-20 heat shrink splice kit for connecting lengths of active heating cable.

A Raychem T-100 tee connection system, certificate PTB20ATEX1008U, for connecting up to three heater cables.

Type S-150 mechanical splice kit, covered by certificate DEKRA20ATEX0011U.

POWER CONNECTIONS

Power connection may be achieved by the following means:

Connection Type	ATEX Certificate
JBM-100	PTB20ATEX1008U
JBS-100	PTB20ATEX1008U
JBU-100	PTB20ATEX1008U
C-150-E	DEKRA20ATEX0011U
C25-21 Connection Kit	Baseefa16ATEX0037U
C25-100 Connection Kit	Baseefa16ATEX0038U
C25-100-Metal / C3/4-100-Metal / C25-100-Metal-NP / C3/4-100- Metal-NP / C25-100-Metal-SS Kits	Baseefa16ATEX0039U

The C25-100-Metal / C3/4-100-Metal / C25-100-Metal-NP / C3/4-100-Metal-NP / C25-100-Metal-SS Kits include M25 or ¾ NPT gland to Sira01ATEX1270X and core sealer to Baseefa15ATEX0194U.

A number of power levels and voltages, up to the maximum specified, are included in the range. They are identified in the following manner:

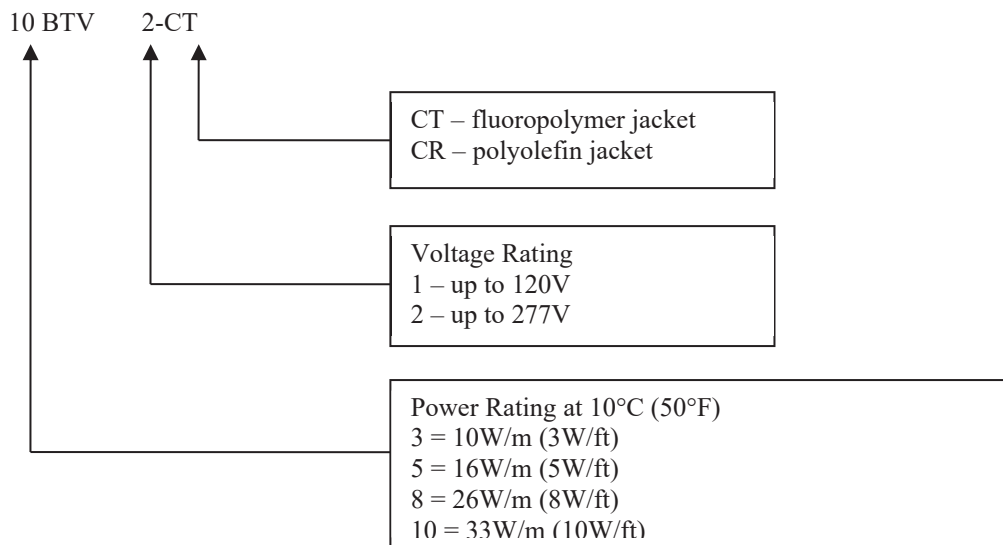

Any of the products in the range may be considered as part of a stabilised design system. In such a system the design is based upon the use of nVent proprietary software Trace calc Pro. The algorithm defined in this software may be used in additional design software.

The minimum bending radii for BTV trace heating cable at specific temperatures are shown in the table below:

Temperature, T (°C)	Minimum Bending Radius (mm)
-60 ≤ T < -20	35
-20 ≤ T < -10	30
-10 ≤ T < 0	25
0 ≤ T < +10	20
T ≥ +10	12

16 Report Number

See Certificate History.

17 Specific Conditions of Use

- The following limiting temperatures for the heat shrink end seals and splices shall not be exceeded:
+110°C for the S-20 and E-20
+150°C for the C-150-E, S-150 and E-150
- The end seals, splices and power connections have the following associated ambient temperatures:
-60°C to +56°C for the E-20 and S-20
-55°C to +56°C for the T-100, JBM-100, JBS-100, JBU-100 and E-100
-40°C to +56°C for the JBS-100-L, JBM-100-L, and JBU-100-L
-55°C to +55°C for the C-150-E, S-150 and E-150
-40°C to +40°C for the E-100-L
-55°C to +110°C for the C25-21 and C25-100
-60°C to +180°C for the C25-100-Metal / C3/4-100-Metal / C25-100-Metal-NP / C3/4-100-Metal-NP / C25-100-Metal-SS
- The assembly of glands, splices and end terminations shall be carried out in accordance with the manufacturing instructions
- The heating element supply circuit must include an electrical protection device in conformity with Clause 4.4 of EN 60079-30-1.
- The minimum installation temperature is -60°C. The minimum bending radii at specific temperatures for the Type BTV units are shown in the table in the equipment description.
- The supply to the heating unit must be terminated in a suitably certified terminal enclosure.
- The minimum installation temperature for E-20 and S-20, end seal and splice is -20°C.
- The installer is to carry out a dielectric strength test on Ex equipment in which the C25-21, C25-100 and C25-100-Metal / C3/4-100-Metal / C25-100-Metal-NP / C3/4-100-Metal-NP / C25-100-Metal-SS connection kit is fitted. No dielectric breakdown shall occur. (Alternatively, an insulation resistance test may be undertaken in accordance with EN 60079-30-2).

18 Essential Health and Safety Requirements

In addition to the Essential Health and Safety Requirements (EHSRs) covered by the standards listed at item 9, the following are considered relevant to this product, and conformity is demonstrated in the report:

Clause	Subject
1.2.7	LVD type requirements
1.2.8	Overloading of equipment (protection relays, etc.)
1.4.1	External effects
1.4.2	Aggressive substances, etc.

19 Drawings and Documents

New drawings submitted for this issue of certificate:

Number	Sheet	Issue	Date	Description
906567 ⁱⁱ	1 of 1	P	05/21/21	C25-21, C25-100 and C25-100-METAL-XX, C3/4-100-METAL-XX Connection Kits

Current drawings which remain unaffected by this issue:

Number	Sheet	Issue	Date	Description
906579-A ⁱ	1 of 1	N	01/15/2021	BTV Heater Units (European System)
205350-A ⁱ	1 of 1	P	03/31/20	BTV-3BTV-CT & BTV-5BTV-CT
205310-A ⁱ	1 of 1	Q	03/31/20	BTV-8BTV-CT & BTV-10BTV-CT
205349-A ⁱ	1 of 1	J	03/26/20	BTV-3BTV-CR & BTV-5BTV-CR
205308-A ⁱ	1 of 1	P	03/26/20	BTV-8BTV-CR & BTV-10BTV-CR
906794-A ⁱⁱⁱ	1 of 1	AA	03/30/20	Generic ATEX and IECEx Print Dwg for BTV-CT, QTVR-CT, XTV-CT, KTV-CT Heating Cables
9242869 ^{iv}	1 & 2	O	12/09/19	LABL JBM-100-L-E
9532687 ^{iv}	1 & 2	Q	12/09/19	LABL JBM-100-L-EP
9621473 ^{iv}	1 & 2	O	12/09/19	LABL JBS-100-L-E
9777523 ^{iv}	1 & 2	P	12/09/19	LABL JBS-100-L-EP
9319676 ^{iv}	1 & 2	O	12/09/19	LABL JBU-100-L-E
9735898 ^{iv}	1 & 2	O	12/09/19	LABL JBU-100-L-EP
908742-A ^v	1 of 1	A	2/19/20	E-20 Heat Shrinkable End Seal Kit Cut Back Dimensions
908743-A ^{vi}	1 of 1	A	2/19/20	S-20 Heat Shrinkable Splice Joint Kit Cut Back Dimensions

- i) These drawings are common to IECEx BAS 20.0011X, SGS20ATEX0048X and are held with IECEx BAS 20.0011X.
- ii) This drawing is common to IECEx BAS 16.0040U, IECEx BAS 16.0041U, IECEx 16.0042U, IECEx BAS 20.0008X, IECEx BAS 20.0009X, IECEx BAS 20.0011X, IECEx BAS 20.0012X, IECEx BAS 20.0013X, IECEx BAS 20.0014X, Baseefa16ATEX0037U, Baseefa16ATEX0038U, Baseefa16ATEX0039U, SGS20ATEX0045X, SGS20ATEX0046X, SGS20ATEX0048X, SGS20ATEX0049X, SGS20ATEX0050X, SGS20ATEX0051X and is held with IECEx BAS 16.0040U.
- iii) These drawings are common to IECEx BAS 20.0011X, IECEx BAS 20.0012X, IECEx BAS 20.0013X, IECEx BAS 20.0014X, SGS20ATEX0048X, SGS20ATEX0049X, SGS20ATEX0050X, SGS20ATEX0051X and are held with IECEx BAS 20.0011X.
- iv) These drawings are common to IECEx BAS 20.0008X, IECEx BAS 20.0011X, IECEx BAS 20.0012X, IECEx BAS 20.0013X, IECEx BAS 20.0014X, SGS20ATEX0045X, SGS20ATEX0048X, SGS20ATEX0049X, SGS20ATEX0050X, SGS20ATEX0051X and are held with IECEx BAS 20.0008X.
- v) These drawings are common to IECEx BAS 20.0010X, IECEx BAS 20.0011X, IECEx BAS 20.0013X, SGS20ATEX0047X, SGS20ATEX0048X, SGS20ATEX0050X and are held with IECEx BAS 20.0010X.
- vi) These drawings are common to IECEx BAS 20.0011X, IECEx BAS 20.0013X, SGS20ATEX0048X, SGS20ATEX0050X and are held with IECEx BAS 20.0011X.

20 Certificate History

Certificate No.	Date	Comments
SGS20ATEX0048X	23 October 2020	The release of the prime certificate. The associated test and assessment against the requirements of EN 60079-0:2012+A11:2013, EN IEC 60079-7:2015+A1:2018, EN 60079-18:2015+A1:2017, EN 60079-30-1:2017 and EN 60079-31:2014 is documented in Test Report No. GB/BAS/ExTR20.0030/00.
SGS20ATEX0048X Issue 1	11 February 2021	To assess the BTV range of self-regulating trace heating systems against EN IEC 60079-0:2018, introduce the low profile power connection, splice and end seal kits, types C-150-E, S-150 and E-150 afforded DEKRA20ATEX0011U, minor amendments to the product description, to change the product name to “BTV Range of Self-Regulating Trace Heating Systems” and to amend the Specific Conditions of Use. The associated test and assessment is documented in Test Report No. GB/BAS/ExTR21.0005/00.

Certificate No.	Date	Comments
SGS20ATEX0048X Issue 2	7 July 2021	Minor drawing updates not affecting certification. Baseefa Certification Report GB/BAS/ExTR21.0060/00 refers.
For drawings applicable to each issue, see original of that issue.		

EU-TYPE EXAMINATION CERTIFICATE

- [2] EQUIPMENT OR PROTECTIVE SYSTEM INTENDED FOR USE IN POTENTIALLY EXPLOSIVE ATMOSPHERES DIRECTIVE 2014/34/EU
- [3] EU-Type Examination Certificate Number: **Presafe 14 ATEX 4124** **Issue 4**
- [4] Product: **Junction boxes**
- [5] Manufacturer: **R. Stahl Tranberg AS**
- [6] Address: **Strandsvingen 6,
4032 Stavanger, NORWAY**
- [7] This product and any acceptable variation thereto is specified in the schedule to this certificate and the documents therein referred to.
- [8] DNV GL Presafe AS, notified body number 2460, in accordance with Article 17 of Directive 2014/34/EU of the European Parliament and of the Council, dated 26 February 2014, certifies that this product has been found to comply with the Essential Health and Safety Requirements relating to the design and construction of products intended for use in potentially explosive atmospheres given in Annex II to the Directive.

The examination and test results are recorded in confidential reports listed in section 16.
- [9] Compliance with the Essential Health and Safety Requirements has been assured by compliance with:
EN 60079-0:2012/A11:2013, EN 60079-1:2014, EN 60079-7:2015, EN 60079-11:2012, EN 60079-18:2015 and EN 60079-28:2015
- [10] If the sign "X" is placed after the certificate number, it indicates that the product is subject to the Specific Conditions of Use specified in the schedule to this certificate.
- [11] This EU - TYPE EXAMINATION CERTIFICATE relates only to the design and construction of the specified product. Further requirements of the Directive apply to the manufacturing process and supply of this product. These are not covered by this certificate.
- [12] The marking of the product shall include the following:

 **II 2 G Ex db eb mb ia/ib op pr IIC Gb T class, see [15]**



Date of issue:
2019-01-18



 Bjørn Spongsveen
 For DNV GL Presafe AS
 The Certificate has been digitally signed.
 See www.dnvgl.com/digitalsignatures for info

[13] **Schedule**

[14] **EU-Type Examination Certificate No:** Presafe 14 ATEX 4124 Issue 4

[15] **Description of Product**

This certificate covers increased safety boxes equipped with different equipment. This includes terminal blocks, signal lamps, push button, control switches, thermostats, bus bars, isolators, baffles, A-bricks and optical splicing box.

The boxes can be used to terminate Ex i circuits, the current and voltage are then limited according to Technical Data.

Termination can be combined with or without Ex e circuits. See limitations for non-is circuits in combination with is circuits in technical standards and document 100A111238

This certification also covers the use of certified optical splicing box in combination with increased safety enclosure.

Type designation

TEF 10aa bb c d	aa bb c d	58 or 59 Dimension: 00 = Customer specific 1 to 99 = Predefined dim. Surface treatment: 0 = Bright chemical dip 1 = Electro polished 2 to 9 Not defined Configuration 0 = Empty enclosure 1 = With horizontal terminal rail PE bar 2 to 9 Not defined.
TEF 1060 a b c	a b c	Enclosure configuration 0 = Hinged with window 2 = Hinged 1, 3 to 9 Not defined Lid configuration 0 = Hinged lid with screw electro polished 1 = Hinged lid with cam lock 2 to 9. Not defined Dimension 0 = Empty enclosure 1 = With horizontal terminal rail and PE bar. 2 to 9. Not defined

TEF 1058256x, TEF 1058258x

TEF 1061

Type designation matrix for TEF 1061 X

X= 1-6 describing enclosure material:

- 1: 1.0330 (1,5-2mm)
- 2: 1.4301 (1,5-2mm)
- 3: 1.4404/1.4571 (1,5-2mm)
- 4: 1.0330 (2,1-3mm)
- 5: 1.4301 (2,1-3mm)
- 6: 1.4404/1.4571 (2,1-3mm)

Operating temperature - T_{amb}

Two different gasket types may be used with the operating temperature range:

TEF1058 and TEF1059:

EPDM gasket -40°C to +80°C and Silicone -60°C to +135°C

TEF1060:

EPDM gasket -20°C to +60°C and Silicone -50°C to +100°C

TEF1061

Seal 1 -60°C to +135°C, seal 2 -55°C to +85°C and seal 3 -25°C to +76°C

The operating temperature range/T_{amb} for the total enclosure, box included optional components are calculated by documented method (100A10247), with minimum/maximum operating temperature -60°C to +135°C, depended if silicone gasket is used. EPDM gives respectively -40°C to +80°C.

Temperature class

T4, T5 or T6
(dependent on internal components and T_{amb})

Electrical Data

Voltage: max 11000V
Amperes: max 2100A (see table below)

Electrical Safety Parameters, is and non-is combination

Voltage: max 90V
Amperes: max 3A
Non-Is voltage: max 1000V

Electrical data, bus bar system

For bus-bar systems, the cable maximum rating is according to IEC TR 60890

Current rating for terminals, not copper bus bar solutions			
Terminal size / Crossection	Load	Terminal size / Crossection	Load
1,5mm ² AWG16	10A	50mm ² AWG1/0	135A
2,5mm ² AWG14	16A	70mm ² AWG2/0	165A
4mm ² AWG12	20A	95mm ² AWG4/0	210A
6mm ² AWG10	25A	120mm ² AWG250	230A
10mm ² AWG8	35A	150mm ² AWG300	250A
16mm ² AWG6	63A	185mm ² AWG400	300A
25mm ² AWG4	80A	240mm ² AWG500	350A
35mm ² AWG1	100A	300mm ² AWG600	450A

Degrees of protection (IP Code)

TEF 10aa bb c d and TEF 1060

IP66 or IP66/67

IP54, with some optional components.

TEF 1061

IP 56 for enclosure version with two hinged and integrated cam locks

IP 66 for all other enclosure versions

Ambient temperature:

-50°C to +100°C (see operating temperature)

Routine tests

A dielectric strength test according to Clause 7.1 of EN 60079-7 shall be carried out on equipment

[16] **Report No.:** D0001170 rev 4

[17] **Specific Conditions of Use**

N/A

[18] **Essential Health and Safety Requirements**

Essential Health and Safety Requirements (EHSRs) are covered by the standards listed at item 9

[19] **Drawings and documents**

Number	Title	Rev.	Date
*TCL4280	Master document	G	2018-11-15
TCL5306	Master document	-	2016-04-06
*TCL5661	Master document	A	2018-11-14
*100A108267	Enclosure label Tranberg terminal boxes	C	2018-11-15
*100A111228	List	B	2018-11-14
100A10247	METHOD FOR CALCULATION OF MAXIMUM DISSIPATED POWER AND NO.OF COMPONENTS	D	2016-04-08

[20] **Certificate History**

Issue	Description	Issue date	Report no.
0	Original issue	2014-05-14	D0001170
1	Addition of bus bar and high voltage equipment	2016-04-11	D0001170 rev1
2	Additional switches and incorporation of ia, ib and op pr equipment	2017-02-02	D0001170 rev2
3	Updated reference to certificates in drawings. Update of standards EN 60079-1, EN 60079-7 and EN 60079-18.	2018-02-05	D0001170 rev3
4	Add new 8150 enclosure to new model TEF1061	2019-01-16	D0001170 rev4

END OF CERTIFICATE

Translation

EU-Type Examination Certificate

Equipment intended for use in potentially explosive atmospheres
Directive 2014/34/EU

EU-Type Examination Certificate Number: **BVS 17 ATEX E 053 X**

Product: **Plug and socket system type GHG 51*** ** R * *****

Manufacturer: **Cooper Crouse-Hinds GmbH**

Address: **Neuer Weg-Nord 49, 69412 Eberbach, Germany**

This product and any acceptable variations thereto are specified in the appendix to this certificate and the documents referred to therein.

DEKRA EXAM GmbH, Notified Body number 0158, in accordance with Article 17 of Directive 2014/34/EU of the European Parliament and of the Council, dated 26 February 2014, certifies that this product has been found to comply with the Essential Health and Safety Requirements relating to the design and construction of products intended for use in potentially explosive atmospheres given in Annex II to the Directive.

The examination and test results are recorded in the confidential Report No. BVS PP 17.2132 EU.

Compliance with the Essential Health and Safety Requirements has been assured by compliance with:

EN 60079-0:2012 + A11:2013	General requirements
EN 60079-1:2014	Flameproof enclosure "d"
EN 60079-7:2015	Increased Safety "e"
EN 60079-11:2012	Intrinsic Safety "i"
EN 60079-31:2014	Protection by Enclosure "t"

If the sign "X" is placed after the certificate number, it indicates that the product is subject to the Special Conditions for Use specified in the appendix to this certificate.

This EU-Type Examination Certificate relates only to the design and construction of the specified product. Further requirements of the Directive apply to the manufacturing process and supply of this product. These are not covered by this certificate.

The marking of the product shall include the following:

 **II 2G Ex db eb [ia] IIC/IIB T6 Gb**
II 2D Ex tb IIIC T80°C Db

DEKRA EXAM GmbH
Bochum, 2017-08-25

Signed: Jörg Koch

Certifier

Signed: Dr Franz Eickhoff

Approver

13 **Appendix**

14 **EU-Type Examination Certificate**
BVS 17 ATEX E 053 X

15 **Product description**

15.1 **Subject and type**

Plug and socket system type GHG	51	*	*	*	**	R	*	***
		1)	2)	3)	4)	5)	6)	

1) Rated current and voltage 1 = 16 A 110 V - 690 V

2) Design
3 = Couple
4 = Wall socket
7 = Plug

3) Number of poles
3 = 3-poles (1+N+PE)
4 = 4-poles (3+PE)
5 = 5-poles (3+N+PE)

4) Voltage
00 = ≤ 24 V AC
01 = 42 V AC (special version low voltage)
03 = 230 V AC
04 = 110/130 V AC
05 = 690 V AC
06 = 230/415 V AC
07 = 500 V AC
08 = special version
09 = 127/230 V
11 = 12 V / 24 V AC (special version low voltage)
12 = 42 V AC

5) Temperature range R = Design variant temperature range

6) Version
0 = Plastic
3 = inset metal plate
5-8 = auxiliary contacts

15.2 **Description**

The plug and socket system type GHG 51*** ** R * *** consist of a flange socket which is built as a wall socket or a couple, which is used for connection of a plug.

The plug is built in type of protection increased safety "e" and protection by enclosure "t".

The wall socket and the couple are built in type of protection increased safety "e" and protection by enclosure "t".

The mounting flange socket type GHG 511 8... .. is separately certified and built in type of protection flameproof enclosure "d", increased safety "e" and protection by enclosure "t".

The wall socket can be equipped with a separately certified mini terminal type 07-9702-0*2*/****, signal lamp type GHG41. R..., switch block type GHG 41. R, miniature limit switch type 07-1501-****/****, terminal type MS(D)B 2,5 *** / UK *** or control unit type GHG 411 8***.

Listing of all components used

Subject and type	Certificate
Flange socket GHG 511 8... ..	BVS 15 ATEX E 101 U
Signal lamp GHG41. R...	IBExU 12 ATEX 1047 U
Switch block GHG 41. R	IBExU 14 ATEX 1030 U
Miniature limit switch 07-1501-****/****	EPS 14 ATEX 1 688 U
Mini terminal 07-9702-0*2*/****	PTB 99 ATEX 3117 U
Feed-through terminal block MS(D)B 2,5 ***	PTB 08 ATEX 1075 U
Terminal Type UK ***	KEMA 98 ATEX 1651 U
Control unit GHG 411 8***	PTB 00 ATEX 3117

15.3 Parameters

Plug and socket system - Wall socket type GHG 51*4* ** R **** (Gas Group IIC/IIB)

Rated voltage: 110 - 690 V AC
 Rated current: 16 A
 Ambient temperature range: -55 °C ... +45 °C

Plug and socket system - Wall socket type GHG 51*4* ** R **** (Gas Group IIC/IIB)

Rated voltage: 110 - 690 V AC
 Rated current: 10 A
 Ambient temperature range: -55 °C ... +55 °C

Plug and socket system - Wall socket type GHG 511 4311 R **** (Gas Group IIC/IIB)

Rated voltage: 42 V AC
 Rated current: 16 A (3-pol.) / without PE (2-pol.)
 Ambient temperature range: -55 °C ... +55 °C

Plug and socket system - Wall socket type GHG 511 4301 R **** (Gas Group IIC/IIB)¹⁾

Rated voltage: 24 V AC
 Rated current: 16 A (3-pol.) / without PE (2-pol.)
 Ambient temperature range: -55 °C ... +55 °C

Plug and socket system - Wall socket type GHG 511 4301 R **** (Gas Group IIC/IIB)¹⁾

Rated voltage: 12 V AC
 Rated current: 16 A (3-pol.) / without PE (2-pol.)
 Ambient temperature range: -55 °C ... +55 °C

Plug and socket system - couple type GHG 51*3* ** R **** (Gas Group IIC/IIB)

Rated voltage: 110 - 690 V AC
 Rated current: 16 A
 Ambient temperature range: -20 °C ... +45 °C

Plug and socket system - couple type GHG 51*3* ** R **** (Gas Group IIC/IIB)

Rated voltage: 110 - 690 V AC
Rated current: 10 A
Ambient temperature range: -20 °C ... +55 °C

Plug and socket system - couple type GHG 511 3311 R **** (Gas Group IIC/IIB)¹

Rated voltage: 42 V AC
Rated current: 16 A (3-pol.) / without PE (2-pol.)
Ambient temperature range: -20 °C ... +55 °C

Plug and socket system - couple type GHG 511 3301 R **** (Gas Group IIC/IIB)¹

Rated voltage: 24 V AC
Rated current: 16 A (3-pol.) / without PE (2-pol.)
Ambient temperature range: -20 °C ... +55 °C

Plug and socket system - couple type GHG 511 3301 R **** (Gas Group IIC/IIB)¹

Rated voltage: 12 V AC
Rated current: 16 A (3-pol.) / without PE (2-pol.)
Ambient temperature range: -20 °C ... +55 °C

Plug and socket system - plug type GHG 51*7* ** R **** (Gas Group IIC/IIB)

Rated voltage: 110 - 690 V AC
Rated current: 16 A
Ambient temperature range: -40 °C ... +45 °C
-55 °C ... +45 °C (see 17)

Plug and socket system - plug type GHG 51*7* ** R **** (Gas Group IIC/IIB)

Rated voltage: 110 - 690 V AC
Rated current: 10 A
Ambient temperature range: -40 °C ... +55 °C
-55 °C ... +55 °C (see 17)

Plug and socket system - plug type GHG 511 7311 R **** (Gas Group IIC/IIB)¹

Rated voltage: 42 V AC
Rated current: 16 A (3-pol.) / without PE (2-pol.)
Ambient temperature range: -40 °C ... +55 °C
-55 °C ... +55 °C (see 17)

Plug and socket system - plug type GHG 511 7301 R **** (Gas Group IIC/IIB)¹

Rated voltage: 24 V AC
Rated current: 16 A (3-pol.) / without PE (2-pol.)
Ambient temperature range: -40 °C ... +55 °C
-55 °C ... +55 °C (see 17)

Plug and socket system - plug type GHG 511 7301 R **** (Gas Group IIC/IIB)¹⁾

Rated voltage: 12 V AC
Rated current: 16 A (3-pol.) / without PE (2-pol.)
Ambient temperature range: -40 °C ... +55 °C
-55 °C ... +55 °C (see 17)

¹⁾ special version

Intrinsic safe circuits (according IExU 12 ATEX 1047 U)

Rated voltage: 10 - 30 V DC
Rated current: max. 25 mA
 U_i 30 V DC
 I_i 100 mA
 P_i 750 mW
 C_i, L_i : negligible

Potential-free switch contact for the connection of an intrinsic safe circuit

Bemessungsspannung: max. 30 V AC / DC
Rated current: max. 400 mA
 C_i, L_i : negligible

16 **Report Number**

BVS PP 17.2132 EU, as of 2017-08-25

17 **Special Conditions for Use**

The plugs of the plug and socket system type GHG 51*7* ** R (Gas Group IIB/IIC) must be protected against mechanical damage > 4 J for an ambient temperature limit below -40 °C.

18 **Essential Health and Safety Requirements**

The Essential Health and Safety Requirements are covered by the standards listed under item 9.

19 **Drawings and Documents**

Drawings and documents are listed in the confidential report.

We confirm the correctness of the translation from the German original.
In the case of arbitration only the German wording shall be valid and binding.

DEKRA EXAM GmbH
Bochum, dated 2017-08-25
BVS-Pz/Nu A 20121416



Certifier



Approver

Translation

EU-Type Examination Certificate Supplement 1

Equipment intended for use in potentially explosive atmospheres
Directive 2014/34/EU

EU-Type Examination Certificate Number: **BVS 17 ATEX E 053 X**

Product: **Plug and socket system type GHG 51*** ** R * *****

Manufacturer: **Cooper Crouse-Hinds GmbH**

Address: **Neuer Weg-Nord 49, 69412 Eberbach, Germany**

This supplementary certificate extends EC-Type Examination Certificate No. BVS 17 ATEX E 053 X to apply to products designed and constructed in accordance with the specification set out in the appendix of the said certificate but having any acceptable variations specified in the appendix to this certificate and the documents referred to therein.

DEKRA EXAM GmbH, Notified Body number 0158, in accordance with Article 17 of Directive 2014/34/EU of the European Parliament and of the Council, dated 26 February 2014, certifies that this product has been found to comply with the Essential Health and Safety Requirements relating to the design and construction of products intended for use in potentially explosive atmospheres given in Annex II to the Directive.

The examination and test results are recorded in the confidential Report No. BVS PP 17.2132 EU.

Compliance with the Essential Health and Safety Requirements has been assured by compliance with:

EN 60079-0:2012 + A11:2013	General requirements
EN 60079-1:2014	Flameproof enclosure "d"
EN 60079-7:2015	Increased Safety "e"
EN 60079-11:2012	Intrinsic Safety "i"
EN 60079-31:2014	Protection by Enclosure "t"

If the sign "X" is placed after the certificate number, it indicates that the product is subject to the Special Conditions for Use specified in the appendix to this certificate.

This EU-Type Examination Certificate relates only to the design and construction of the specified product. Further requirements of the Directive apply to the manufacturing process and supply of this product. These are not covered by this certificate.

The marking of the product shall include the following:

 **II 2G Ex db eb [ia] IIC/IIB+H₂/IIB T6 Gb**
II 2D Ex tb IIIC T80°C Db

DEKRA EXAM GmbH
Bochum, 2018-01-24

Signed: Dr Franz Eickhoff

Certifier

Signed: Dr Michael Wittler

Approver

13 **Appendix**
 14 **EU-Type Examination Certificate**

**BVS 17 ATEX E 053 X
 Supplement 1**

15 **Product description**

15.1 **Subject and Type**

Plug and socket system type GHG	51	*	*	*	**	R	*	***
		1)	2)	3)	4)	5)	6)	

- 1) Rated current and voltage 1 = 16 A 110 V - 690 V
- 2) Design
 - 3 = Couple
 - 4 = Wall socket
 - 7 = Plug
- 3) Number of poles
 - 3 = 3-poles (1+N+PE)
 - 4 = 4-poles (3+PE)
 - 5 = 5-poles (3+N+PE)
- 4) Voltage
 - 00 = ≤ 24 V AC
 - 03 = 230 V AC
 - 04 = 110/130 V AC
 - 05 = 690 V AC
 - 06 = 230/415 V AC
 - 07 = 500 V AC
 - 08 = special version
 - 09 = 127/230 V
 - 12 = 42 V AC
- 5) Temperature range
 - R = Design variant temperature range
- 6) Version
 - 0 = Plastic
 - 3 = inset metal plate
 - 5-8 = auxiliary contacts

15.2 **Description**

The plug and socket system type GHG 51*** ** R * *** consists of a flange socket which is built as a wall socket or a couple, which is used for connection of a plug.

The plug is built in type of protection increased safety "e" and protection by enclosure "t".

The wall socket and the couple are built in type of protection increased safety "e" and protection by enclosure "t".

The mounting flange socket type GHG 511 8... .. is separately certified and built in type of protection flameproof enclosure "d", increased safety "e" and protection by enclosure "t".

The wall socket can be equipped with a separately certified mini terminal type 07-9702-0*2*/****, signal lamp type GHG41. R..., switch block type GHG 41. R, miniature limit switch type 07-1501-****/****, terminal type MS(D)B 2,5 *** / UK *** or control unit type GHG 411 8***.



Listing of all components used

Subject and type	Certificate
Flange socket GHG 511 8... ..	BVS 15 ATEX E 101 U
Signal lamp GHG41. R...	IBExU 12 ATEX 1047 U
Switch block GHG 41. R	IBExU 14 ATEX 1030 U
Miniature limit switch 07-1501-****/****	EPS 14 ATEX 1 688 U
Mini terminal 07-9702-0*2*/****	PTB 99 ATEX 3117 U
Feed-through terminal block MS(D)B 2,5 ***	PTB 08 ATEX 1075 U
Terminal Type UK ***	KEMA 98 ATEX 1651 U
Control unit GHG 411 8***	PTB 00 ATEX 3117

Reason of the supplement:

- Modification of the ambient temperature range for wall socket type GHG 51*4* ** R ****
- Addition of the Gas Group IIB+H₂

15.3

Parameters

Plug and socket system - Wall socket type GHG 51*4* ** R **** (Gas Group IIB/IIB+H₂/IIC) - Flange socket standard material

Rated voltage: 110 - 690 V AC
 Rated current: 16 A
 Ambient temperature range: -55 °C ... +45 °C

Plug and socket system - Wall socket type GHG 51*4* ** R **** (Gas Group IIB+H₂/IIC) - Flange socket standard material

Rated voltage: 110 - 690 V AC
 Rated current: 10 A
 Ambient temperature range: -55 °C ... +55 °C

Plug and socket system - Wall socket type GHG 51*4* ** R **** - Flange socket alternative material

Rated voltage: 110 - 690 V AC
 Rated current: max. 16 A (3-pol.) / without PE (2-pol.)
 Ambient temperature range: -45 °C ... +55 °C (Gas Group IIB)
 -30 °C ... +55 °C (Gas Group IIB+H₂)
 -20 °C ... +55 °C (Gas Group IIC)

Plug and socket system - Wall socket type GHG 51*4* ** R **** - Flange socket alternative material

Rated voltage: 110 - 690 V AC
 Rated current: max. 16 A (4-pol. / 5-pol.)
 Ambient temperature range: -55 °C ... +55 °C (Gas Group IIB/IIB+H₂)
 -20 °C ... +55 °C (Gas Group IIC)

Plug and socket system - Wall socket type GHG 511 4311 R **** (Gas Group IIC/IIB)¹⁾ -
Flange socket standard material

Rated voltage: 42 V AC
Rated current: 16 A (3-pol.) / without PE (2-pol.)
Ambient temperature range: -55 °C ... +55 °C

Plug and socket system - Wall socket type GHG 511 4301 R **** (Gas Group IIC/IIB)¹⁾ -
Flange socket standard material

Rated voltage: 24 V AC
Rated current: 16 A (3-pol.) / without PE (2-pol.)
Ambient temperature range: -55 °C ... +55 °C

Plug and socket system - Wall socket type GHG 511 4301 R **** (Gas Group IIC/IIB)¹⁾ -
Flange socket standard material

Rated voltage: 12 V AC
Rated current: 16 A (3-pol.) / without PE (2-pol.)
Ambient temperature range: -55 °C ... +55 °C

Plug and socket system - Wall socket type GHG 511 4311 R **** (Gas Group IIC/IIB)¹⁾ -
Flange socket alternative material

Rated voltage: 42 V AC
Rated current: 16 A (3-pol.) / without PE (2-pol.)
Ambient temperature range: -45 °C ... +55 °C (Gas Group IIB)
-30 °C ... +55 °C (Gas Group IIB+H₂)
-20 °C ... +55 °C (Gas Group IIC)

Plug and socket system - Wall socket type GHG 511 4301 R **** (Gas Group IIC/IIB)¹⁾ -
Flange socket alternative material

Rated voltage: 24 V AC
Rated current: 16 A (3-pol.) / without PE (2-pol.)
Ambient temperature range: -45 °C ... +55 °C (Gas Group IIB)
-30 °C ... +55 °C (Gas Group IIB+H₂)
-20 °C ... +55 °C (Gas Group IIC)

Plug and socket system - Wall socket type GHG 511 4301 R **** (Gas Group IIC/IIB)¹⁾ -
Flange socket alternative material

Rated voltage: 12 V AC
Rated current: 16 A (3-pol.) / without PE (2-pol.)
Ambient temperature range: -45 °C ... +55 °C (Gas Group IIB)
-30 °C ... +55 °C (Gas Group IIB+H₂)
-20 °C ... +55 °C (Gas Group IIC)

Plug and socket system - couple type GHG 51*3* ** R **** (Gas Group IIC/IIB) -
standard material

Rated voltage: 110 - 690 V AC
Rated current: 10 A
Ambient temperature range: -20 °C ... +55 °C

Plug and socket system - couple type GHG 51*3* ** R **** (Gas Group IIC/IIB) - standard material

Rated voltage: 110 - 690 V AC
Rated current: 16 A
Ambient temperature range: -20 °C ... +45 °C

Plug and socket system - couple type GHG 51*3* ** R **** (Gas Group IIC/IIB/IIB+H₂) - alternative material

Rated voltage: 110 - 690 V AC
Rated current: 16 A
Ambient temperature range: -20 °C ... +45 °C

Plug and socket system - couple type GHG 511 3311 R **** (Gas Group IIC/IIB)¹ - standard material

Rated voltage: 42 V AC
Rated current: 16 A
Ambient temperature range: -20 °C ... +55 °C

Plug and socket system - couple type GHG 511 3301 R **** (Gas Group IIC/IIB)¹ - standard material

Rated voltage: 24 V AC
Rated current: 16 A
Ambient temperature range: -20 °C ... +55 °C

Plug and socket system - couple type GHG 511 3301 R **** (Gas Group IIC/IIB)¹ - standard material

Rated voltage: 12 V AC
Rated current: 16 A
Ambient temperature range: -20 °C ... +55 °C

Plug and socket system - couple type GHG 511 3311 R **** (Gas Group IIC/IIB/IIB+H₂) - alternative material

Rated voltage: 42 V AC
Rated current: 16 A
Ambient temperature range: -20 °C ... +55 °C

Plug and socket system - couple type GHG 511 3301 R **** (Gas Group IIC/IIB/IIB+H₂)¹ - alternative material

Rated voltage: 24 V AC
Rated current: 16 A
Ambient temperature range: -20 °C ... +55 °C

Plug and socket system - couple type GHG 511 3301 R **** (Gas Group IIC/IIB/IIB+H₂) - alternative material

Rated voltage: 12 V AC
Rated current: 16 A
Ambient temperature range: -20 °C ... +55 °C

Plug and socket system - plug type GHG 51*7* ** R **** (Gas Group IIC/IIB/IIB+H₂)

Rated voltage: 110 - 690 V AC
Rated current: 16 A
Ambient temperature range: -40 °C ... +45 °C
-55 °C ... +45 °C (see 17)

Plug and socket system - plug type GHG 51*7* ** R **** (Gas Group IIC/IIB/IIB+H₂)

Rated voltage: 110 - 690 V AC
Rated current: 10 A
Ambient temperature range: -40 °C ... +55 °C
-55 °C ... +55 °C (see 17)

Plug and socket system - plug type GHG 511 7311 R **** (Gas Group IIC/IIB/IIB+H₂)¹⁾

Rated voltage: 42 V AC
Rated current: 16 A (3-pol.) / without PE (2-pol.)
Ambient temperature range: -40 °C ... +55 °C
-55 °C ... +55 °C (see 17)

Plug and socket system - plug type GHG 511 7301 R **** (Gas Group IIC/IIB)¹⁾

Rated voltage: 24 V AC
Rated current: 16 A
Ambient temperature range: -40 °C ... +55 °C
-55 °C ... +55 °C (see 17)

Plug and socket system - plug type GHG 511 7301 R **** (Gas Group IIC/IIB)¹⁾

Rated voltage: 12 V AC
Rated current: 16 A
Ambient temperature range: -40 °C ... +55 °C
-55 °C ... +55 °C (see 17p)

¹⁾ special version

Intrinsic safe circuits (according IExU 12 ATEX 1047 U / IECEx IBE 13.0031U)

Rated voltage: 10 - 30 V DC
Rated current: max. 25 mA
U_i: 30 V DC
I_i: 100 mA
P_i: 750 mW

C_i, L_i: negligible

Potential-free switch contact for the connection of an intrinsic safe circuit

Rated voltage: max. 30 V AC / DC
Rated current: max. 400 mA

C_i, L_i: negligible

16 **Report Number**

BVS PP 17.2132 EU, as of 2018-01-24

17 **Special Conditions for Use**

The plugs of the plug and socket system type GHG 51*7* ** R (Gas Group IIB/IIC/IIB+H₂) must be protected against mechanical damage > 4 J for an ambient temperature limit below -40 °C.

18 **Essential Health and Safety Requirements**

The Essential Health and Safety Requirements are covered by the standards listed under item 9.

19 **Drawings and Documents**

Drawings and documents are listed in the confidential report.

We confirm the correctness of the translation from the German original.
In the case of arbitration only the German wording shall be valid and binding.

DEKRA EXAM GmbH
Bochum, dated 2018-01-24
BVS-Pz/Nu A 20171078



Certifier

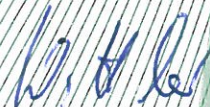

Approver

Translation

EU-Type Examination Certificate Supplement 2

Equipment intended for use in potentially explosive atmospheres
Directive 2014/34/EU

EU-Type Examination Certificate Number: **BVS 17 ATEX E 053 X**

Product: **Plug and socket system type GHG 51*** ** R * *****

Manufacturer: **Cooper Crouse-Hinds GmbH**

Address: **Neuer Weg-Nord 49, 69412 Eberbach, Germany**

This supplementary certificate extends EC-Type Examination Certificate No. BVS 17 ATEX E 053 X to apply to products designed and constructed in accordance with the specification set out in the appendix of the said certificate but having any acceptable variations specified in the appendix to this certificate and the documents referred to therein.

DEKRA EXAM GmbH, Notified Body number 0158, in accordance with Article 17 of Directive 2014/34/EU of the European Parliament and of the Council, dated 26 February 2014, certifies that this product has been found to comply with the Essential Health and Safety Requirements relating to the design and construction of products intended for use in potentially explosive atmospheres given in Annex II to the Directive.

The examination and test results are recorded in the confidential Report No. BVS PP 17.2132 EU.

Compliance with the Essential Health and Safety Requirements has been assured by compliance with:

EN 60079-0:2012 + A11:2013	General requirements
EN 60079-1:2014	Flameproof enclosure "d"
EN 60079-7:2015	Increased Safety "e"
EN 60079-11:2012	Intrinsic Safety "i"
EN 60079-31:2014	Protection by Enclosure "t"

If the sign "X" is placed after the certificate number, it indicates that the product is subject to the Special Conditions for Use specified in the appendix to this certificate.

This EU-Type Examination Certificate relates only to the design and construction of the specified product. Further requirements of the Directive apply to the manufacturing process and supply of this product. These are not covered by this certificate.

The marking of the product shall include the following:

 **II 2G Ex db eb [ia] IIC/IIB+H₂/IIB T6 Gb**
II 2D Ex tb IIIC T80°C Db

DEKRA EXAM GmbH
Bochum, 2018-03-19

Signed: Jörg Koch

Certifier

Signed: Dr Franz Eickhoff

Approver



13 **Appendix**
 14 **EU-Type Examination Certificate**

**BVS 17 ATEX E 053 X
 Supplement 2**

15 **Product description**

15.1 **Subject and Type**

Plug and socket system type GHG	51	*	*	*	**	R	*	***
		1)	2)	3)	4)	5)	6)	

1) Rated current and voltage 1 = 16 A 110 V - 690 V

2) Design
 3 = Couple
 4 = Wall socket
 7 = Plug

3) Number of poles
 3 = 3-poles (1+N+PE)
 4 = 4-poles (3+PE)
 5 = 5-poles (3+N+PE)

4) Voltage
 00 = ≤ 24 V AC
 03 = 230 V AC
 04 = 110/130 V AC
 05 = 690 V AC
 06 = 230/415 V AC
 07 = 500 V AC
 08 = special version
 09 = 127/230 V
 12 = 42 V AC

5) Temperature range R = Design variant temperature range

6) Version
 0 = Plastic
 3 = Inset metal plate
 5-8 = Auxiliary contacts

15.2 **Description**

The plug and socket system type GHG 51*** ** R * *** consists of a flange socket which is built as a wall socket or a couple, which is used for connection of a plug.

The plug is built in type of protection Increased Safety "e" and Protection by Enclosure "t".

The wall socket and the couple are built in type of protection Increased Safety "e" and Protection by Enclosure "t".

The mounting flange socket type GHG 511 8... is separately certified and built in type of protection Flameproof Enclosure "d", Increased Safety "e" and Protection by Enclosure "t".

The wall socket can be equipped with a separately certified mini terminal type 07-9702-0*2*/****, signal lamp type GHG41. R..., switch block type GHG 41. R, miniature limit switch type 07-1501-****/****, terminal type MS(D)B 2,5 *** / UK *** or control unit type GHG 411 8***.



Listing of all components used

Subject and type	Certificate
Flange socket GHG 511 8... ..	BVS 15 ATEX E 101 U
Signal lamp GHG41. R...	IBExU 12 ATEX 1047 U
Switch block GHG 41. R	IBExU 14 ATEX 1030 U
Miniature limit switch 07-1501-****/****	EPS 14 ATEX 1 688 U
Mini terminal 07-9702-0*2*/****	PTB 99 ATEX 3117 U
Feed-through terminal block MS(D)B 2,5 ***	PTB 08 ATEX 1075 U
Terminal Type UK ***	KEMA 98 ATEX 1651 U
Control unit GHG 411 8***	PTB 00 ATEX 3117

Reason of the supplement:

- Addition an increased ambient temperature range for the plug T_{amb} : +55 °C

15.3 **Parameters**

Plug and socket system - Wall socket type GHG 51*4* ** R **** (Gas Group IIB/IIB+H₂/IIC) - Flange socket standard material

Rated voltage: 110 - 690 V AC
 Rated current: 16 A
 Ambient temperature range: -55 °C ... +45 °C

Plug and socket system - Wall socket type GHG 51*4* ** R **** (Gas Group IIB+H₂/IIC) - Flange socket standard material

Rated voltage: 110 - 690 V AC
 Rated current: 10 A
 Ambient temperature range: -55 °C ... +55 °C

Plug and socket system - Wall socket type GHG 51*4* ** R **** - Flange socket alternative material

Rated voltage: 110 - 690 V AC
 Rated current: max. 16 A (3-pol.) / without PE (2-pol.)
 Ambient temperature range: -45 °C ... +55 °C (Gas Group IIB)
 -30 °C ... +55 °C (Gas Group IIB+H₂)
 -20 °C ... +55 °C (Gas Group IIC)

Plug and socket system - Wall socket type GHG 51*4* ** R **** - Flange socket alternative material

Rated voltage: 110 - 690 V AC
 Rated current: max. 16 A (4-pol. / 5-pol.)
 Ambient temperature range: -55 °C ... +55 °C (Gas Group IIB/IIB+H₂)
 -20 °C ... +55 °C (Gas Group IIC)

Plug and socket system - couple type GHG 51*3** R **** (Gas Group IIC/IIB) - standard material

Rated voltage: 110 - 690 V AC
Rated current: 16 A
Ambient temperature range: -20 °C ... +45 °C

Plug and socket system - couple type GHG 51*3** R **** (Gas Group IIC/IIB/IIB+H₂) - alternative material

Rated voltage: 110 - 690 V AC
Rated current: 16 A
Ambient temperature range: -20 °C ... +45 °C

Plug and socket system - couple type GHG 511 3311 R **** (Gas Group IIC/IIB)¹ - standard material

Rated voltage: 42 V AC
Rated current: 16 A
Ambient temperature range: -20 °C ... +55 °C

Plug and socket system - couple type GHG 511 3301 R **** (Gas Group IIC/IIB)¹ - standard material

Rated voltage: 24 V AC
Rated current: 16 A
Ambient temperature range: -20 °C ... +55 °C

Plug and socket system - couple type GHG 511 3301 R **** (Gas Group IIC/IIB)¹ - standard material

Rated voltage: 12 V AC
Rated current: 16 A
Ambient temperature range: -20 °C ... +55 °C

Plug and socket system - couple type GHG 511 3311 R **** (Gas Group IIC/IIB/IIB+H₂) - alternative material

Rated voltage: 42 V AC
Rated current: 16 A
Ambient temperature range: -20 °C ... +55 °C

Plug and socket system - couple type GHG 511 3301 R **** (Gas Group IIC/IIB/IIB+H₂)¹ - alternative material

Rated voltage: 24 V AC
Rated current: 16 A
Ambient temperature range: -20 °C ... +55 °C

Plug and socket system - couple type GHG 511 3301 R **** (Gas Group IIC/IIB/IIB+H₂) - alternative material

Rated voltage: 12 V AC
Rated current: 16 A
Ambient temperature range: -20 °C ... +55 °C



Plug and socket system - plug type GHG 51*7* ** R **** (Gas Group IIC/IIB/IIB+H₂)

Rated voltage: 110 - 690 V AC
 Rated current: 16 A
 Rated cross section: 2.5 mm²
 Ambient temperature range: -40 °C ... +45 °C
 -55 °C ... +45 °C (see 17)

Plug and socket system - plug type GHG 51*7* ** R **** (Gas Group IIC/IIB/IIB+H₂)

Rated voltage: 110 - 690 V AC
 Rated current: 16 A
 Rated cross section: 4 mm²
 Ambient temperature range: -40 °C ... +55 °C
 -55 °C ... +55 °C (see 17)

Plug and socket system - plug type GHG 51*7* ** R **** (Gas Group IIC/IIB/IIB+H₂)

Rated voltage: 110 - 690 V AC
 Rated current: 10 A
 Rated cross section: 2.5 mm²
 Ambient temperature range: -40 °C ... +55 °C
 -55 °C ... +55 °C (see 17)

Plug and socket system - plug type GHG 511 7311 R **** (Gas Group IIC/IIB/IIB+H₂)¹⁾

Rated voltage: 42 V AC
 Rated current: 16 A (3-pol.) / without PE (2-pol.)
 Ambient temperature range: -40 °C ... +55 °C
 -55 °C ... +55 °C (see 17)

Plug and socket system - plug type GHG 511 7301 R **** (Gas Group IIC/IIB)¹⁾

Rated voltage: 24 V AC
 Rated current: 16 A
 Ambient temperature range: -40 °C ... +55 °C
 -55 °C ... +55 °C (see 17)

Plug and socket system - plug type GHG 511 7301 R **** (Gas Group IIC/IIB)¹⁾

Rated voltage: 12 V AC
 Rated current: 16 A
 Ambient temperature range: -40 °C ... +55 °C
 -55 °C ... +55 °C (see 17p)

¹⁾ special version

Intrinsically safe circuits (according IBExU 12 ATEX 1047 U / IECEx IBE 13.0031U)

Rated voltage:	10 - 30	V DC
Rated current:	max. 38.7	mA
U_i	30	V DC
I_i	120	mA
P_i	750	mW

C_i, L_i : negligible

Potential-free switch contact for the connection of an intrinsically safe circuit

Rated voltage:	max. 30	V AC / DC
Rated current:	max. 400	mA

C_i, L_i : negligible

16 Report Number

BVS PP 17.2132 EU, as of 2018-03-19

17 Special Conditions for Use

The plugs of the plug and socket system type GHG 51*7* ** R (Gas Group IIB/IIC/IIB+H₂) must be protected against mechanical damage > 4 J for an ambient temperature limit below -40 °C.

18 Essential Health and Safety Requirements

The Essential Health and Safety Requirements are covered by the standards listed under item 9.

19 Drawings and Documents

Drawings and documents are listed in the confidential report.

We confirm the correctness of the translation from the German original.
In the case of arbitration only the German wording shall be valid and binding.

DEKRA EXAM GmbH
Bochum, dated 2018-03-19
BVS-Pz/Mu A 20180143

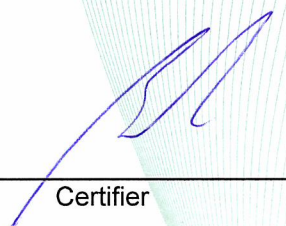

Certifier



Approver