

OPERATING INSTRUCTIONS

SBS 255

Part No. 152786

For the important safety of your body, please read this manual book and understand its contents before operation.

1 Security instruction

Operation manual

For your own security read the operation manual before starting the machine. The operation manual should be kept in a secure place. You should know about how to handle the machine, its limits and its specific dangers.

Keep your working place clean

Disorder on your working place will result in danger. Take care that your working place is free from chips and dirt. Use only the right tools to clean your machine from chips. Keep your working place free from obstacles.

Check if there are any damages at the machine

Before you start the machine check the function of the security equipment. Check the function of all movable parts. All parts have to be mounted correctly. Damaged security parts should be repaired or exchanged by the after sales service.

Take care about outer conditions

Don't use the machine in dangerous areas. Take care, that electrical parts don't get humid or wet. Work only with a good illumination. Don't use electrical parts near flammable fluids or gas.

Protect yourself from electric shock

Don't remove mechanical or electrical security parts. Check if all security parts are mounted and adequately functioning.

Wear only suitable clothes

Don't wear large clothes, wristwatches or jewels. For your own security wear always working shoes while working. If you have long hair always wear a hairnet. While working with the machine you have to wear security glasses. If you work under dusty conditions you have to wear a dust protection breathing mask.

Keep incompetent persons away from the working area

Take care, that there are no persons in your working area which could be exposed to danger. Children and visitors should be kept in a secure distance to the working area.

Keep children away from the machine.

Don't let other people touch the machine or the cable of the machine. Make sure that only authorised persons can reach the workshop.

Take care about the Power supply cable

Before connecting the power supply cable to the wall socket ensure that the machine is switched off. Don't use the cable to pull the plug out of the socket. Take care, that there is no tensile force on the cable. Beware the power supply cable from heat, oil and sharp edges. Control the plug and the cable regular and in case of damage let it repair by the after sales service. Please control also the extension cable. Never use the machine without Protection Earth.

Unplug the machine

If you don't use and while servicing the machine pull off the power supply plug. This is necessary because the machine should not run unintentionally and to protect you from electric shock.

Beware of unintentional run

Confirm that the main power switch is off while you plug in the power supply plug.

Be careful with your tools

Keep your tools sharp and clean to work good and secure. Follow the instructions for tool exchange and servicing.

Don't forget tools inside the machine

Before starting make sure that there are no tools inside the machine which could be hurled out of the machine. Make sure, that there are no loosen parts witch could be dangerous.

Take care about your hands

Make sure, that tools and work pieces are securely fastened. Use only the right tools to clamp and to fasten tools and work pieces. This is more secure than to fasten the work piece with the hand, and you have two hands to handle the machine.

Pay attention to your balance

Take care about the position of your feed. Never climb on the machine, because dangerous injury may result from falling down or contacting moving parts.

Accessories and accessory parts

Only use accessories and accessory parts witch are specified by the operation manual or the supplier. The use of other accessories and accessory parts may result in dangerous injury and damage the machine. Only use accessories and accessory parts for the right tasks.

Electrical parts

The electrical parts confirm to the determinations of electrical security.

Mending may only be done by electric specialist to prevent accidents for the user.

Cleaning solvent

Before you work with cleaning solvent you should read the instruction of the fluid, to prevent accidents.

Leaving the machine

Never leave the machine while it is running.

Alcohol, medicaments, drugs

Never use the machine under influence of alcohol, medicaments or drugs

Danger of fire

Don't use highly inflammable fluids.

Sound level data (establishment. 89/392/EEC)

In conformity with clause (1.7.4.f) of attachment 1 from the directive for safety of the industry equipment 89/392/EEC we declare the measured noise values at work with the machine as less or equal than 82 dB(A).

1 REFERENCE TO ACCIDENT - PREVENTION REGULATIONS

This machine has been built to comply with the national and Community accident-prevention regulations in force. Improper use and/or tampering with the safety devices will relieve the manufacturer of all responsibility.

1.1- Advice for the Operator



- Check that the voltage indicated on the plate, normally fixed to the machine motor, is the same as the line voltage.
- Check the efficiency of your electric supply and earthing System; connect the power cable of the machine to the socket and the earth lead (yellow-green in colour) to the earthing System.
- When the saw frame is in suspend mode (up) the toothed blade must not move.
- Only the blade section used for cutting must be kept unprotected. Remove guarding by operating on the adjustable head.
- It is forbidden to work on the machine without its shields (these are all blue or grey in colour).
- Always disconnect the machine from the power socket before blade change or carrying out any maintenance job, even in the case of abnormal machine Operation.
- It is forbidden to disconnect the "man presence device, known more correctly in the EEC as the "safety switch with hold-down action".
- Always wear suitable eye protection.
- Never put your hands or arms into the cutting area while the machine is operating.
- Do not shift the machine while it is cutting.
- Do not wear loose clothing with sleeves that are too long, gloves that are too big, bracelets, chains or any other object that could get caught in the machine during Operation; tie back long hair.
- Keep the area free of equipment, tools or any other object.
- Perform only one Operation at a time and never have several objects in your hands at the same time. Keep your hands as clean as possible.
- All internal and/or internal Operations, maintenance or repairs, must be performed in a well-lit area or where there is sufficient light from extra sources so as to avoid the risk of even slight accidents.

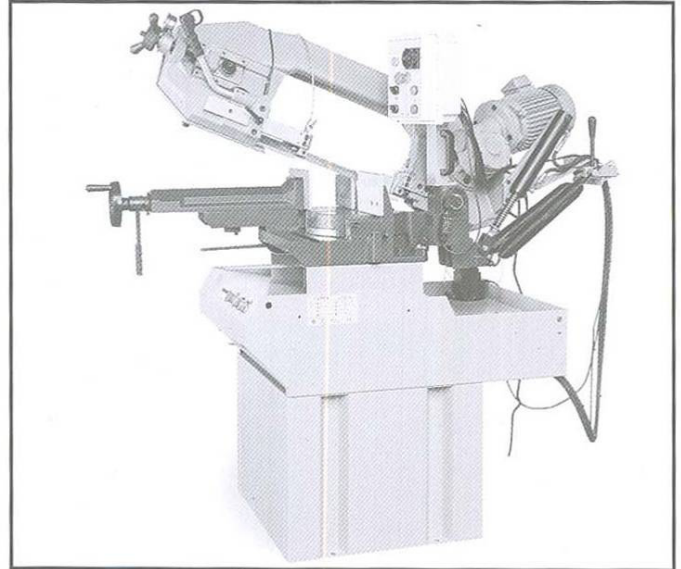

1.2 - Location of shields against accidental contact with the tool

- Blue, grey metal guards, fastened with screws onto the stationary blade-guide and relevant holding arm.
- Blue or grey metal guard fastened with screws onto the mobile blade-guide, ensures covering of blade section not used in cutting Operation.
- Grey metal guards fastened with knobs onto the saw frame, to protect from flywheels.

1-3 - Electrical equipment according to European Standard CENELEC EN 60 204-1" which assimilates, with some integrating modifications, the publication "IEC 204-1"

- The electrical equipment ensures protection against electric shock as a result of direct or indirect contact. The active parts of this equipment are housed in a box to which access is limited by screws that can only be removed with a special tool; the parts are fed with alternating current at low voltage (24 V). The equipment is protected against splashes of water and dust.
- Protection of the System against short circuits is ensured by means of rapid fuses and earthing; in the event of motor overload, protection is provided by a thermal probe.
- In the event of a power cut, the specific start-up button must be reset.
- The machine has been tested in conformity with point 20 of EN 60204.

1.4 - Emergencies according to European Standard "CENELEC EN 60 204-1"

- In the event of incorrect Operation or of danger conditions, the machine may be stopped immediately by pressing the red mushroom button.
- The casual or voluntary removal of the protection shield of the flywheels causes the stepping-in of a microswitch that automatically stops all machine functions.

NOTE: Resetting of machine Operation after each emergency stop is achieved by reactivating the specific restart button.

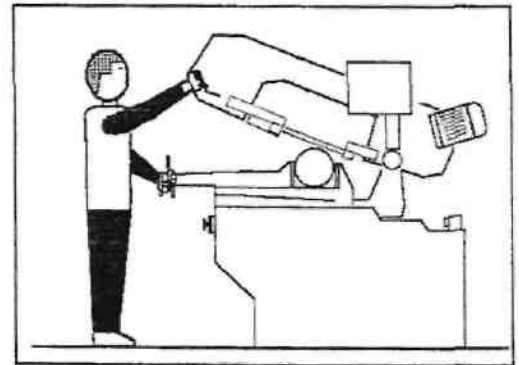
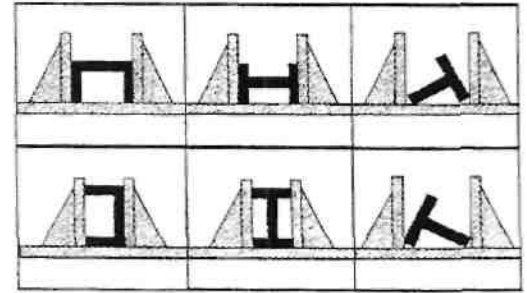

2 RECOMMENDATIONS AND ADVICE FOR USE



2.1 - Recommendations and advice for using the machine

- The machine has been designed to cut metal building materials, with different shapes and profiles, used in Workshops, turner's shops and general mechanical structural work.
- Only one Operator is needed to use the machine, that must stand as shown in the picture.
- Do not use blades of a different size form those stated in the machine specifications.
- If the blade gets stuck in the cut, release the running button immediately, switch off the machine, open the vice slowly, remove the part and check that the blade or its teeth are not broken. If they are broken, change the tool.
- Check saw frame return spring to ensure proper balancing.
- Before carrying out any repairs on the machine, consult the dealer or apply

- Before starting each cutting Operation, ensure that the part is firmly gripped in the vice and that the end is suitably supported. These figures show examples of suitable clamping of different section bars, bearing in mind the cutting capacities of the machine in order to achieve a good efficiency and blade durability.

3 TECHNICAL CHARACTERISTICS

3.1 - Table of cutting capacity and technical details

			
0°	255	230	315x230
-45° DX	195	195	195x230
-60° DX	115	115	115 x 160
45° SX	160	160	160x160

MACHINE DIMENSIONS 4 TRANSPORT INSTALLATION DISMANTLING

4.1 - Machine dimensions

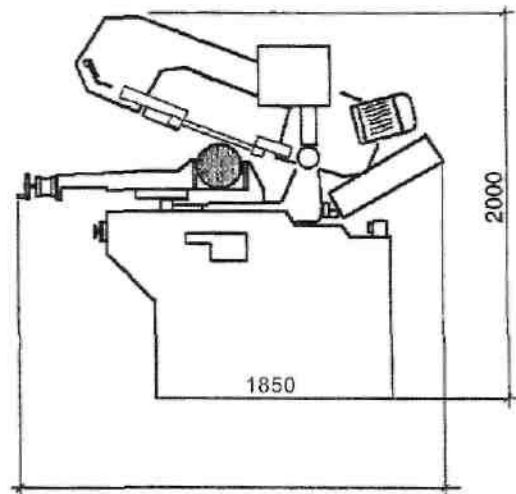

TECHNICAL DATA

BLADE MOTOR	Kw	1.5
COOLANT LIQUID		
MOTOR	KW	0,11
BLADE DIMENSIONS	mm	2750 x 27 x 0,9
FLYWHEEL	mm	330
CUTTING SPEED	m/1'	35-70
VICE OPENING	mm	310
Working Table Height	mm	950
MACHINE WEIGHT	kg	380

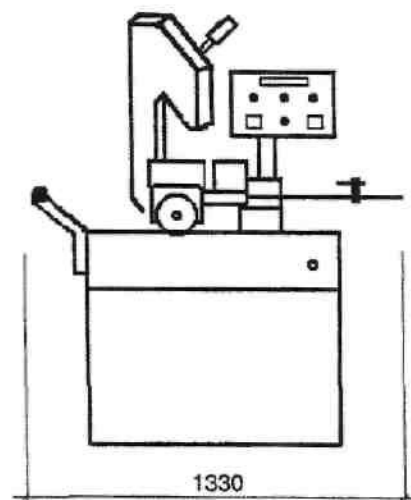

4.2 - Transport and handling of the machine

If the machine has to be shifted in its own packing, use a forklift truck or sling it with Straps as illustrated.

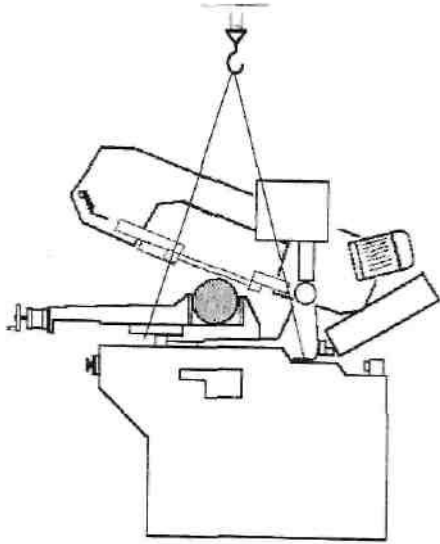

4.3 - Minimum requirements for the premises housing the machine

- Mains voltage and frequency complying with the machine motor characteristics.
- Environment temperature from -10°C to +50°C.
- Relative humidity not over 90%

4.4 - Instructions for electrical connection

- The machine is not provided with an electric plug, so the customer must fit a suitable one for his own working conditions:

1 - WIRING DIAGAM FOR 4-WIRE SYSTEM FOR THREE-PHASE MACHINE-SOCKET FOR A 16A PLUG

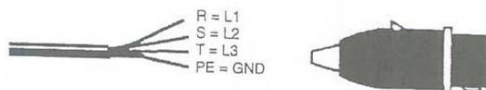

4.5 - Instructions for assembly of the loose parts and accessories

Fit the components supplied as indicated in the photo:

- Mount bar-stop rod
- Mount and align the roll supporting arm as per the countervice table.

4.6 - Disactivating the machine

- If the sawing machine is to be out of use for a long period, it is advisable to proceed as follows:
 - 1) detach the plug from the electric supply panel
 - 2) loosen blade
 - 3) release the arch return spring
 - 4) empty the coolant tank
 - 5) carefully clean and grease the machine
 - 6) if necessary, cover the machine.

4.7 - Dismantling

(because of deterioration and/or obsolescence)

General rules

If the machine is to be permanently demolished and/or scrapped, divide the material to be disposed of according to type and composition, as follows:

- 1) Cast iron or ferrous materials, composed of metal alone, are **secondary raw materials**, so they may be taken to an iron foundry for re-smelting after having removed the contents (classified in point3);
- 2) electrical components, including the cable and electronic material (magnetic cards, etc.), fall within the category of material classified as being assimilable to urban waste according to the laws of the European Community, so they may be set aside for collection by the public waste disposal Service;
- 3) old mineral and synthetic and/or mixed oils, emulsified oils and greases are special refuse, so they must be collected, transported and subsequently disposed of by the old oil disposal service.

NOTE:since Standards and legislation concerning refuse in gen-eral is in a State of contiuous evolurion and therefore subject to vchanges and variations, the user must keep informed of the regulations in force at the time of disposing of the machine tool, as these may differ from those described above, which are to be considered as a gen-eral guide line.

5 MACHINE FUNCTIONAL PARTS

FRAME

5.1 - Operating head or saw frame

-
- Machine part consisting of the members that transfer the motion (garmotor, flywheels), and tension/guide (blade-guides, blade tension slide) and lowering control (optional) of tool.

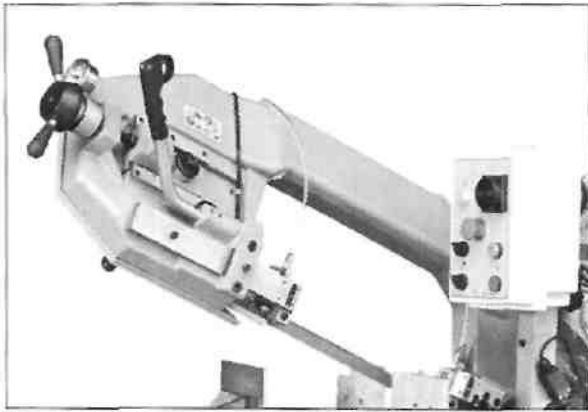

5.2- Vice

- System for clamping the material during the cutting Operation, operated with approach handwheel and locking lever or by a pneumatic device (optional).

5.3 -Bed

- Support structure for the OPERATING HEAD OR SAW

(rotating arm for gradual cutting, with respective blocking System), the ELECTRIC BOX, the VICE, the BAR STOP, the material support ROLLER and the housing for the cutting coolant TANK and pump.

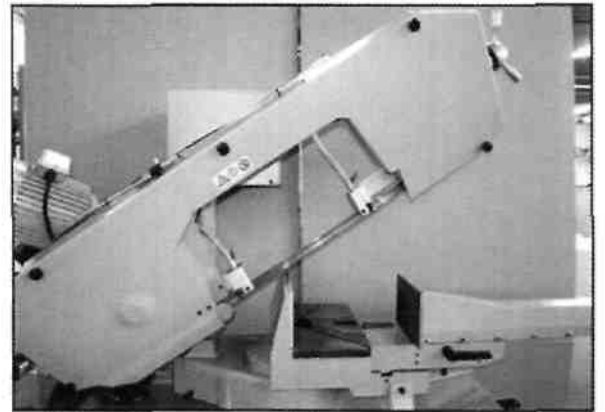

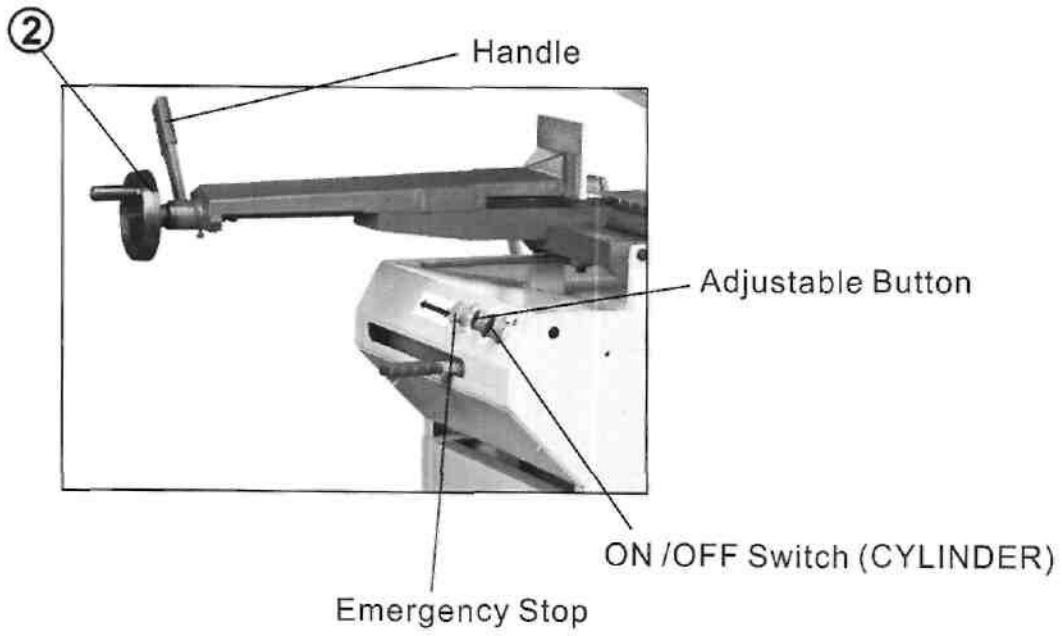

6 DESCRIPTION OF THE OPERATING CYCLE

Before operating, all the main organs of the machine must be set in Optimum conditions (see the chapter on "Regulating the machine").

6.1 - Starting up and cutting cycle

CUTTING CYCLE

Manual vice locking; Manual sawframe downfeed; Manual sawframe lift; Manuale vice opening.

- Make sure the machine is not in emergency stop; if so, re-lease the red mushroom push-button.
- Rotate the band tightening flywheel (2) counterclockwise and the rapid tightening lever towards the left against the mechanical stop
- Select the cutting speed on swich

Position 1 = 36 m/min

Position 2 = 72 m/min

ATTENTION: Make sure that the vice has been positioned to the far right or left of the countervice to avoid accidental impact with the sawblade. ALSO make sure that the relevant lever has been locked (also see Chapter 7 paragraph 7.4).

- Place the piece to be cut inside the vice by moving jaw to about 3-4mm and lock with lever(8).
- Stricke the strat/reset push-button
- If saw is supplied with a saw frame lowering control device, adjust it so as to suit the feaures and the shape of the material to be cut.
- Reach for handgrip (7) of the SAW FRAME control lever, strike the push-button and check that the blade is tuming in the direction indicated (if not, invert the tow phase leads);
- Make sure that the cooling liquid flows regularly.

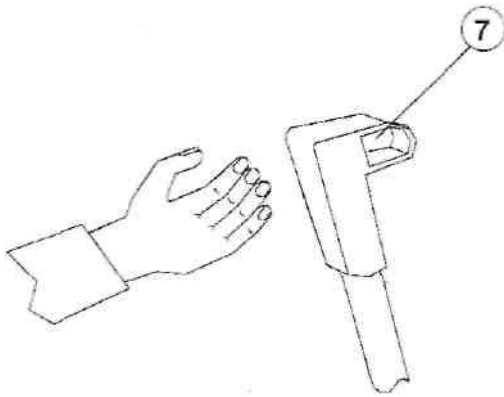

The band saw is now ready to Start work, bearing in mind that the CUTTING SPEED and the TYPE of BLADE - combined with a suitable descent of the head - are of decisive importance for cutting quaiity and for machine Performance (for further details on this topic, see below in the chapter on "Material Classification and blade selection").

- When starting to cut with a new blade, in order to safe-guard its life and efficiency, the first two or three cuts must be made while exerting a slight pressure on the part, so that the time taken to cut is about double the normal time (see below in the chapter on "Material Classification and blade selection" in the section on Blade running-in).
- Press the red emergency button when there are conditions of danger or malfunctions in general, so as to stop machine Operation immediately.

6.2. Foundation requirement

The foundation of the machine should be concrete with 150mm in depth. No special Vibration absorption rubber is needed.

6.3. Unpacking

(Pile 2 sets only)

Removing first the top cover of the wooden case, carefully taking out fittings, Stripping the side plates, then hoist the machine to its position.



Keep your hands off the cutting area

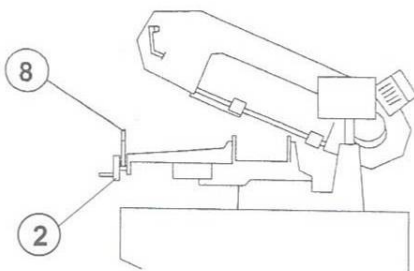
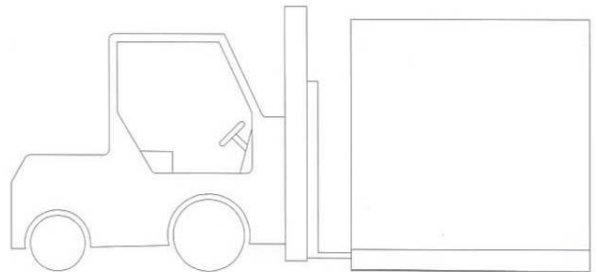

7 REGULATING THE MACHINE

7.1 - Blade tension assembly

The ideal tightening of the blade is achieved by rotating the blade tightening handwheel (B) towards the left against the mechanical stop pin. Ideal tightening of the blade read on the relative pressure bar (C)

Note: In case the saw is not used for a period of time, release blade pressure to the green area.

Always use blade having the dimensions specified in this manual.

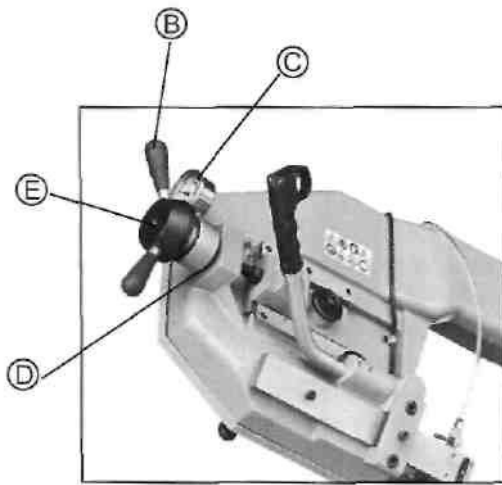

7.2 - Restoring oil level on blade tightening cylinder

The blade pressure can be read on the pressure gauge (C), mounted on the relative blade tightening cylinder allowing constant display of the blade tension. Ideal tightening of the blade

Should any problems in the monitoring of the tension occur, this may be caused by the reduced capacity inside the blade tightening cylinder due to an oil leak.

Simply push the blade tightening cylinder stem (E) back into place and then restore oil level through plug (D). Use SHELL HYDRAULIC OIL 32 type oil or similar. When this operation has been completed, close the plug (D) and tighten the blade.

7.3- Blade guide blocks

The blade is guided by means of adjustable pads set in place during inspection as per the thickness of the blade with minimum play as shown in the figure.

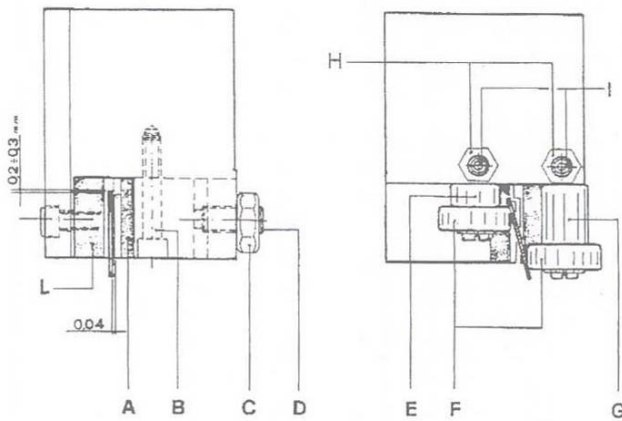

- In case the blade needs to be replaced, make sure to always install 0.9 mm thick blades for which the blade guide pads have been adjusted. In the case of toothed blades with different thick-nesses adjustment should be carried out as follows:
- Loosen nut(C), screw(B)and loosen dowel(D) widening the passage between the pads.
 - Loosen the nuts(H) and the dowels(I) and rotate the pins (E-G) to widen the passage between the bearings(F).
 - Mount the new blade, place the pad(A) on the blade and, loosening the dowel, allow a play of 0.04 mm for the sliding of the toothed blade; lock the relative nut and screw(B):
 - Rotate the pins (E-G) until the bearings rest against the blade as indicated in the figure and then secure the dowels (I) and nut(H).
 - Make sure that between the blade and the upper teeth of the pad(L) this is at least 0.2 - 0.3mm of play; if necessary, loosen the screws that fasten the blocks and adjust accordingly.

BEFORE PERFORMING THE-FOLLOWING OPERATIONS, THE ELECTRIC POWER SUPPLY AND THE POWER CABLE MUST BE COMPLETELY DISCONNECTED.

7.4 - Changing the blade

In case the blade is replaced:

- Lift the saw frame in upmost position.
- Loosen the blade with the handwheel, remove the mobile blade-guide cover, open the flywheel guard and remove the old blade from the flywheels and the blade guide blocks.
- Install the new blade by threading it into the bloc bearings and then inside the flywheel races. Make sure that teeth are in the cutting direction.
- Tighten blade and make sure that it perfectly fits inside the race of the flywheels.
- Mount the mobile blade-guide cover and dose the flywheel guard with the relative clips and check that the safety microswitches are actuated otherwise the machine will not start when you restore electrical connections.

WARNING: always assemble blades having dimensions specified in this manual and for which the blade guide heads have been set: otherwise, see chapter on "Description of the operating cycle" in the section Starting-up.

CUTTING DIRECTION

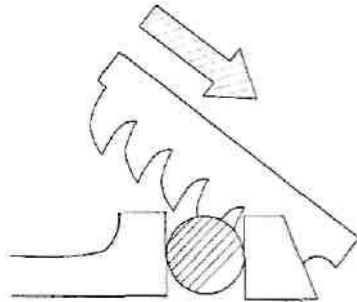

7.5-Replacing saw frame return spring

- When performing this Operation it is necessary to keep saw frame up using the lifting device.
- Replace the spring by loosening the upper coupling rod and releasing it from the lower tie-rod.

ROUTINE.

8 AND SPECIAL MAINTENANCE

THE MAINTENANCE JOBS ARE LISTED BELOW, DIVIDED INTO DAILY, WEEKLY, MONTHLY AND SIX-MONTHLY INTERVALS. IF THE FOLLOWING OPERATIONS ARE NEGLECTED, THE RESULT WILL BE PREMATURE WEAR OF THE MACHINE AND POOR PERFORMANCE.

8.1 - Daily maintenance

- General cleaning of the machine to remove accumulated shavings.
- Clean the lubricating coolant drain hole to avoid excess fluid.
- Top up the level of lubricating coolant.
- Check blade for wear.
- Rise of saw frame to top position and partial slackening of the blade to avoid useless yield stress.

- Check functionality of the shields and emergency stops.

8.2 - Weekly maintenance

- More accurate general cleaning of the machine to remove shavings, especially from the lubricant fluid tank.
- Removal of pump from its housing, cleaning of the suction filter and suction zone.
- Clean the filter of the pump suction head and the suction area.
- Cleaning with compressed air the blade guide heads (guide bearings and drain hole of the lubricating cooling).
- Cleaning flywheel housings and blade sliding surfaces on flywheels.
- Check condition of the blade cleaning brushes.

8.3 - Monthly maintenance

- Check the tightening of the motor flywheel screws.
- Check that the blade guide bearings on the heads are in perfect running condition.
- Check the tightening of the screws of the gearmotor, pump and accident protection guarding.

8.4 - Six-monthly maintenance

REDUCTION UNIT

- The worm drive gear box mounted on the machine is maintenance-free guaranteed by its manufacture.
- Continuity test of the equipotential protection circuit.

8.5 - Oils for lubricating coolant

Considering the vast range of products on the market, the user can choose the one most suited to his own requirements, using as reference the type SHELL LUTEM OIL ECO. THE MINIMUM PERCENTAGE OF OIL DILUTED IN WATER IS 8-10 %.

8.6 - Oil disposal

The disposal of these products is controlled by strict regulations. Please see the chapter on "**Machine dimensions** - Transport - Installation" in the section on *Dismantling*.

8.7 - Special maintenance

Special maintenance Operations must be carried out by skilled personnel. However, we advise contacting their dealer and/or importer. Also the reset of protective and safety equipment and devices, of the reducer, the motor, the motor pump and electric components is to be considered extraordinary maintenance.

9 MATERIAL CLASSIFICATION AND CHOICE OF TOOL

Since the aim is to obtain excellent cutting quality, the various Parameters such as hardness of the material, shape and thickness, transverse cutting section of the part to be cut, selection of the type of cutting blade, cutting speed and control of saw frame lowering. These specifications must therefore be harmoniously combined in a Single operating condition according to practical considerations and common sense, so as to achieve an optimum condition machine when there are many variations in the Job to be performed. The various problems that crop up from time to time will be solved more easily if the Operator has a good knowledge of these specifications.

WE THEREFORE RECOMMEND YOU TO ALWAYS USE GENUINE SPARE BLADES THAT GUARANTEE SUPERIOR QUALITY AND PERFORMANCE.

9.1- Definition of materials

The table at the foot of this page lists the characteristics of the materials to be cut, so as to choose the right tool to use.

9.2 - Selecting blade

First of all the pitch of the teeth must be chosen, in other words, the number of teeth per inch (25.4mm) suitable for the material to be cut, according to these criteria:



- parts with a thin and/or variable section such as profiles, pipes and plate, need close toothing, so that the number of teeth used simultaneously in cutting is from 3 to 6;
- parts with large transverse sections and solid sections need widely spaced toothing to allow for the greater volume of the shavings and better tooth penetration;
- parts made of soft material or plastic (light alloys, mild bronze, teflon, wood, etc.) also require widely spaced toothing;
- pieces cut in bundles require combo tooth design.

9.3 - Teeth pitch

As already stated, this depends on the following factors:

- **hardness of the material**
- **dimensions of the section**
- **thickness of the wall.**

BLADE TEETH SELECTION TABLE		
THICKNESS MM	2 CONTINUOUS TOOTH DESIGN	Z COMBO TOOTH DESIGN
TILL 1.5	14	10/14
FROM 1 TO 2	8	8/12
FROM 2 TO 3	6	6/10
FROM 3 TO 5	6	5/8
FROM 4 TO 6	6	4/6
MORE THAN 6	4	4/6







TYPES OF STEEL						CHARACTERISTICS		
USE	I UNI	D DIN	F AF NOR	GB SB	USA AISI-SAE	Hardness ROCKWELL HRB	Hardness ROCKWELL HRB	R=N/mm2
Construction steels	Fe360	St37	E24	---	---	116	67	360+480
	Fe430	St44	E28	43	---	148	80	430+560
	Fe510	St52	E36	50	---	180	88	510+660
Carbon Steels	C20	CK20	XC20	060 A 20	1020	198	93	540+690
	C40	CK40	XC42H1	060 A 40	1040	198	93	700+840
	C50	CK50	---	---	1050	202	94	760+900
	C60	CK60	XC55	060 A 62	1060	202	94	830+980
Spring steels	50CrV4	50CrV4	50CV4	735 A 50	6150	207	95	1140+1330
	60SiCr8	60SiCr7	---	---	9262	224	98	1220+1400
Alloyed steels for hardening and tempering and for nitriding	35CrMo4	34CrMo04	35CD4	708 A 37	4135	220	98	780+930
	39NiCrMo4	36CrNiMo04	39NCD4	---	9840	228	99	880+1080
	41CrAlMo7	41CrAlMo7	40CADG12	905 M 39	---	232	100	930+1130
Alloyed casehardening steels	18NiCrMo7	---	20NCD7	En 325	4320	232	100	760+1030
	20NiCrMo2	21NiCrMo2	20NCD2	805 H 20	4315	224	98	690+980
Alloyed for bearings	100Cr6	100Cr6	100C6	534 A 99	52100	207	95	690+980
Tool steel	52NiCrMoKU	56NiCrMoV7C100K	---	---	---	244	102	800+1030
	C100KU	C100W1	---	BS1	S-1	212	96	710+980
	X210Cr13KU	X210Cr12	Z200C12	BD2-BD3	D6-D3	252	103	820+1060
	58SiMo8KU	---	Y60SC7	---	S5	244	102	800+1030
Stainless steels	X12Cr13	4001	---	---	410	202	94	670+885
	X5CrNi1810	4301	Z5CN18.09	304 C 12	304	202	94	590+685
	X8CrNi1910	---	---	---	---	202	94	540+685
	X8CrNiMo1713	4401	Z6CDN17.12	316 S 16	316	202	94	490+685
Copper alloys Special brass Bronze	Aluminium copper alloy G-CuAl11Fe4Ni4 UNI 5275					220	98	620+685
	Special manganese/silicon brass G-CuZn36Si1Pb1 UNI5038					140	77	375+440
	Manganese bronze SAE43 - SAE430					120	69	320+410
	Phosphor bronze G-CuSn12 UNI 7013/2a					100	56.5	265+314
Cast iron	Gray pig iron		G25			212	96	245
	Spheroidal graphite cast iron		GS600			232	100	600
	Malleable cast iron		W40-05			222	98	420

Set

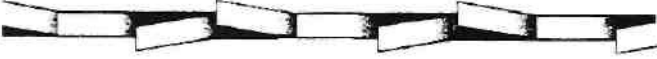
Saw teeth bent out of the plane of the saw body, resulting in a wide cut in the workpiece.



REGULAR OR RAKER SET: Cutting teeth right and left, alternated by a straight tooth.

This set is associated with very fine teeth and it is mainly used for the cutting of pipes and thin section bars (from 1 to 3 mm).

ALTERNATE SET (IN GROUPS): Groups of cutting teeth right

and left, alternated by a straight tooth.



This set is associated with very fine teeth and it is used for extremely thin materials (less than 1 mm).

Of general use for materials with dimensions superior to 5 mm. Used for the cutting of steel, Castings and hard nonferrous materials.

WAVY SET: Set in smooth waves.



ALTERNATE SET (INDIVIDUAL TEETH): Cutting teeth right and left.



This set is used for the cutting of nonferrous soft materials, plastics and wood.

9.7.1 - RECOMMENDED CUTTING PARAMETERS

STEEL	CUTTING SPEED	LUBRICATION
CONSTRUCTION	60/80	EMULSIFIABLE OIL
CEMENTATION	40/50	EMULSIFIABLE OIL
CARBON STEEL	40/60	EMULSIFIABLE OIL
HARDENING AND TEMPERING	40/50	EMULSIFIABLE OIL
BEARINGS	40/60	EMULSIFIABLE OIL
SPRINGS	40/60	EMULSIFIABLE OIL
FOR TOOLS	30/40	EMULSIFIABLE OIL
FOR VALES	35/50	EMULSIFIABLE OIL
STAINLESS STEEL	30/40	EMULSIFIABLE OIL
SPHEROIDAL GRAPHITE	20/40	EMULSIFIABLE OIL
CAST IRON	40/60	EMULSIFIABLE OIL
ALUMINIUM	80/600	KEROSENE
BRONZE	70/120	EMULSIFIABLE OIL
HARD BRONZE	30/60	EMULSIFIABLE OIL
BRASS	70/350	EMULSIFIABLE OIL
COPPER	50/720	EMULSIFIABLE OIL

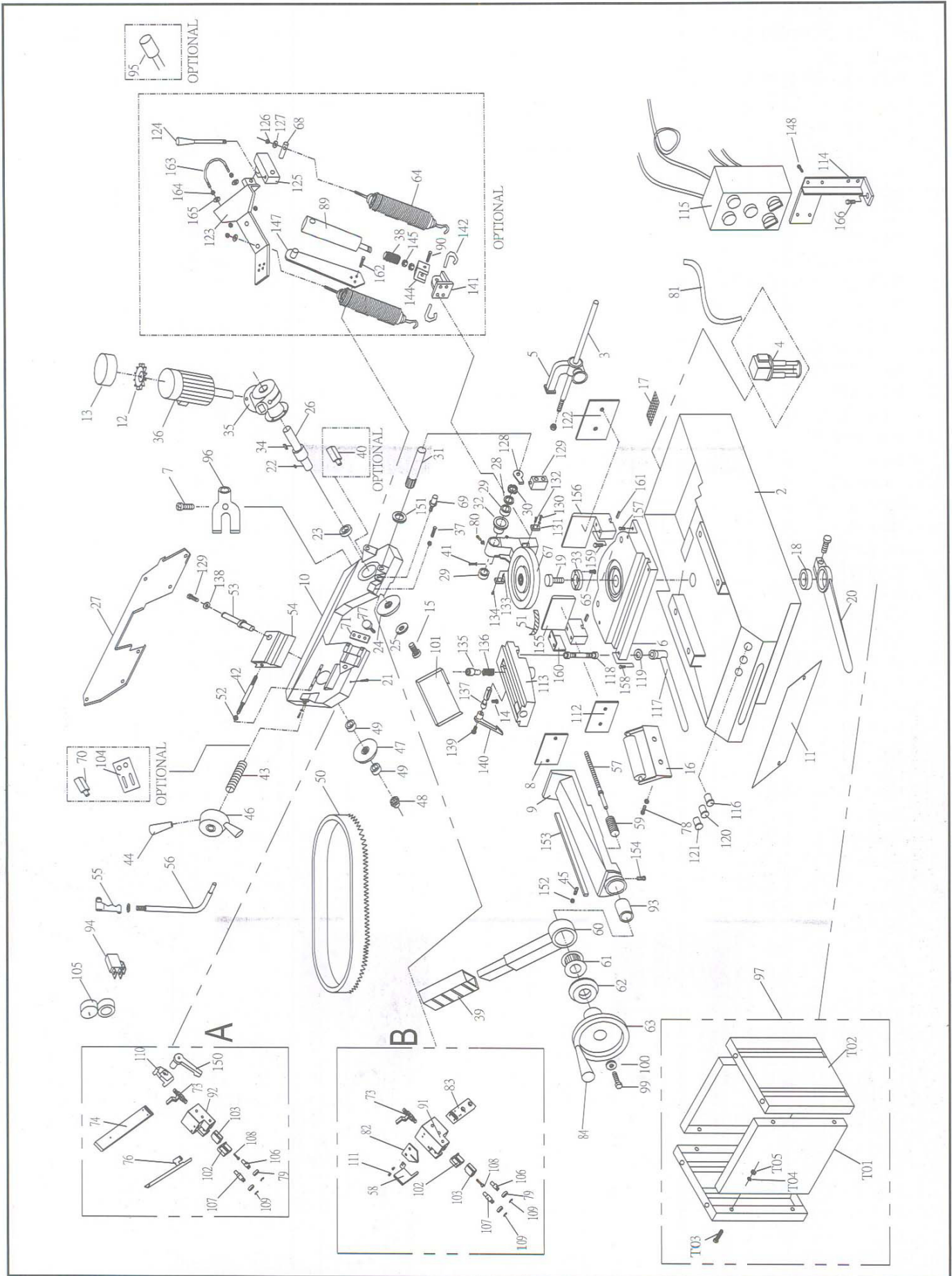

ELECTRICAL CIRCUIT DIAGRAM CY-300R AC400V/3 ϕ (M/A)

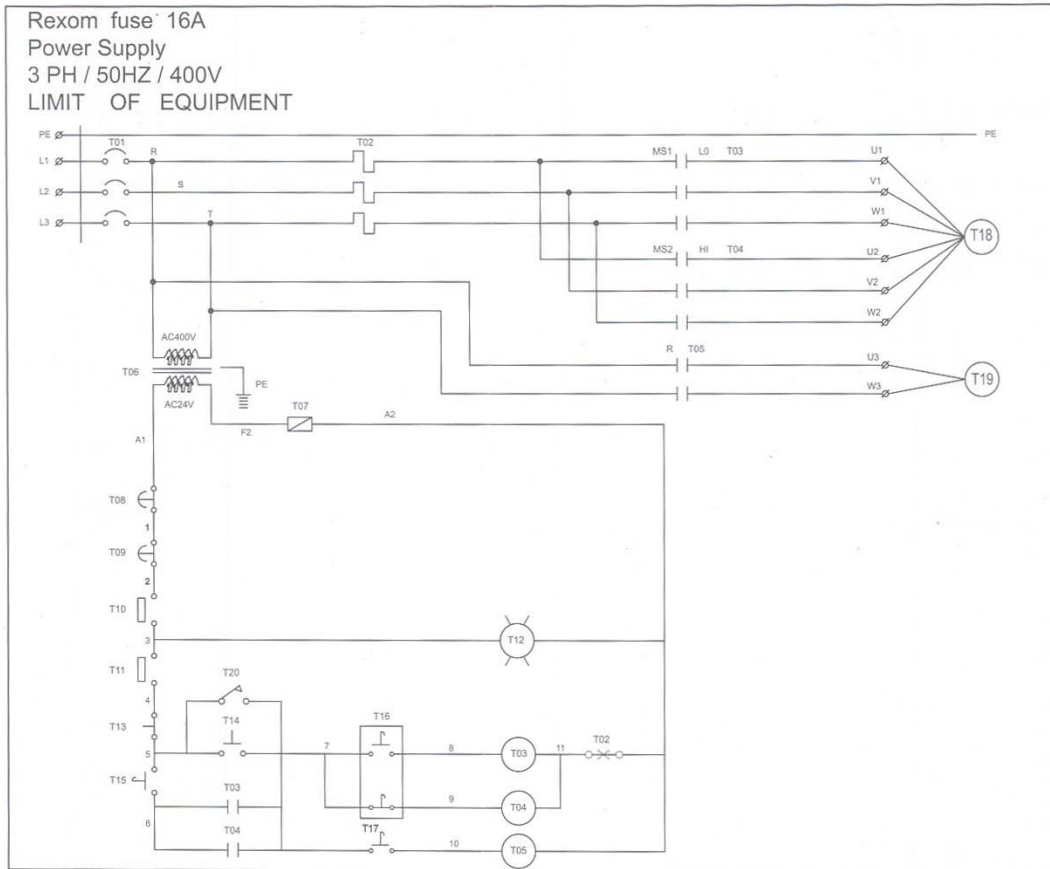

Electrical parts list

Part No	Name	Dscription	Producer	Mark
T01	POWER	CAM SWITCH	SAIZER	CE
T02	O.L	OVER RELAY	SHIHLIN	CE
T03	MS1	MS	SHIHLIN	CE
T04	MS2	MS	SHIHLIN	CE
T05	R	RELAY	RY	CE
T06	TR	TRANSFORMER	GOROGÉ	CE
T07	F1	FUSE	DEMEX	CE
T08	EMS1	EMERGENCY STOP	CIRO	CE
T09	EMS2	EMERGENCY STOP	CIRO	CE
T10	SAFE MICRO	MICRO SWITCH	HAILY	CE
T11	DOWN MICRO	MICRO SWITCH	CT	CE
T12	LAMP	POWER LAMP	TELEMECANIQUE	CE
T13	OFF	O SWITCH	TELEMECANIQUE	CE
T14	ON	I SWITCH	TELEMECANIQUE	CE
T15	M/A	M/A SWITCH	TELEMECANIQUE	CE
T16	SPEED	SPEED SWITCH	TELEMECANIQUE	CE
T17	COOL	COOL SWITCH	TELEMECANIQUE	CE
T18	M1	SAW MOTOR	GOROGÉ	CE
T19	M2	PUMP MOTOR	GOROGÉ	CE
T20	START	START MICRO	HAILY	CE



PARTS LIST

Ref. No. Description	Ref. No. Description	Ref. No. Description
2. Base,	57.Vice screw	116.On /Off Oil Switch
3. Bar stop rod	58.R. Bladeguard	117.Handle
4. Cool pump	59.Vice spring	118.Bolt
5. Bar stop	60.Vice lever,	119.Washer
6. Countervice,	61.Bearing 51105	120.Adjusting Button
7. Screw M5	62.Bearing cover	121.Emergency Stop
8. Vice jaw	63.Vice handwheel	122.Screw
9. Vice	64.Spring	123.Bracket
10.Body frame	65.Screw	124.Handle.
11.Casing,	67.Revolving arm	125.Square
12.Motor Fan	68.Shaft	126.Nut
13.Motor Cover	69.Stop bolt	127.Washer
14.Screw,	70.Micro switch(optional)	128.Cut off plate.
15.Screw,		129.Screw
16.Roller	71.Block	130.Screw
17.Filter	73.Rubber connection.	131.Vice Jaw block
18.Bush	74.Arm	132.Screw
19.Pin	75.Bolt	133.Screw
20.Lever	76.Blade guard	134.Screw
21.Knob	77.Handle	135.Crescent seat
22.Key 7x7	79.Bearing 6082Z	136.Spring
23.Bearing 6208	80.Screw M8	137.Shaft
24.Motor flywheel	81.Water pipe	138.Washer.
25.Washer	82.Rust plate	139.Screw
26.Shaft	83.Vice pad	140.Grip
27.Blade cover	84.Handle	141.Cylinder seat.
28.Ring nilons	89.Hydraulic cylinder	142.Spring hook
29.Bearing 32007	90.Pin	144.□ seat.
30.Ring nut M30	91.Fixed bladeguide plate	145.Nut
31.Pivot.	92.Mobile bladeguide plate/	147.Braket
32.Bearing cover		148.Screw
33.Washer,	93.Bush	150.Grip
34.Key 4x25	94.Toger switch.	151.Gasket
35.Reducer	95.Condenser(motor)(optional)/	152.Nut
36.Motor		153.Key
37.Screw	96.Coolant distributor	154.Screw
38.Spring	97.Stand	155.Vice seat L.
39.Plastic case	99.Screw M8*15	156.Vice seat R.
40.Micro switch(optional)/	100.Washer	157.Screw
	101.Plate	158.Screw
41.Screw M8	102.Bladeguide unit square/	159.Screw
42.Threaded shaft		160.L Board/ L
43.Spring washer	103.Bladeguide unit	161.Square Key
44.Grip	104.Blade tension guide(optional)	162.Screw
45.Pin		162.Screw
46.Handwheel	105.Blade tension gauge	164.Nut
47.Return flywheel	106.Guide pivot	165.Washer
48.Hex. Nut,	107.Guide pivot	166.Screw
49.Bearings 32006	108.33MM*MS Screw	
50.Saw blade	109.C-ring	
51.Scale	110.Fixed plate	
52.Hex. Nuts	111.Screw	
53.Blade sheel shaft	112.Vice jaw	
54.Block blade tension	113.Vice sliding seat	
55.Handle	114.Switch Bracket	
56.Lever.	115.Electrical box	