

SP 4400 / 5008 HST



THE 32 SERIES



SP 4400 / 5008 HST: code name "Municipal"



The SP 4400 HST (38 HP) and SP 5008 HST (46 HP) are articulated hydrostatic, compact, super-handling tractors designed for the maintenance of pedestrian areas and city centres, the cleaning of roadways and pavements, snow clearance and the care of public parks and gardens. The SP can be fitted with front, top and rear fitting equipment whilst maintaining good working speeds. It can be used with the street sweeper, snow blade or cutter, gritter, sand spreader, grass mower (for mulching or cutting and collection), as well as with the front forklift with implement carrier, embankment mower, excavator, front tiller and drill. A convenient loading platform on the back of the bonnet renders the SP useful during material movement.

The cab is its selling point; the living space is bigger and it has 360° all round visibility. Its fabric, pneumatically sprung seat with standard head and armrests provides maximum drive comfort. The cab is fitted on Silent-block that gently absorb vibrations. The vehicle with all of its (standard) details is a must for discerning and demanding customers; amongst which, there is the packed-lunch box and the air conditioning system along with a powerful headlight system and a 12V outlet.

The engines are environmentally friendly in terms of emissions and acoustic comfort since working pleasure has become an essential for the modern municipal worker, as can be seen from the results of the questionnaire carried out on this vehicle's potential customers by Antonio Carraro's R&D Department. As far as mechanical innovations are concerned, the SP uses rear reducers that increase stability and handling, in addition to the hydraulically controlled brakes that guarantee decisive modular braking. The foot pedal hydraulically operates the hydrostatic transmission contributing to drive comfort in terms of practicality and safety.

The JM™ joystick which controls the equipment is ergonomically positioned so that the operator has everything close to hand. In addition, for the tasks that require constantly controlled movement the operator can use the speed-fix device that holds a given speed during operation. The "SP concept" leaves nothing to chance and makes this a truly multipurpose vehicle, a non plus ultra for civil sector operators.

The cherry on the cake: the SP enjoys the up to 4 years extended warranty package (EXG). What more could one ask?



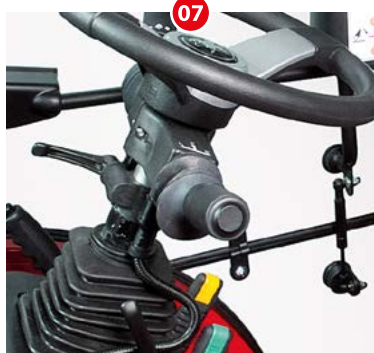

360° COMFORT

- 01 - HEADLIGHTS ON MUDGUARDS AND ROOF (front and rear)
- 02 - PARTIAL OPENING OF THE DOOR AND DEFLECTOR
- 03 - ERGONOMIC WINDOW WASH CONTAINER
- 04 - MULTIPURPOSE INSTRUMENT
- 05 - 3 GLOVE COMPARTMENTS - 12V OUTLET
- 06 - DOOR WITH LOWER HORIZONTAL OPENING
- 07 - ELECTROHYDRAULIC INVERTER
- 08 - AUTOMOBILE HANDLES
- 09 - INTELLIGENT VENTILATION
- 10 - AIR CONDITIONING
- 11 - STEERING WHEEL ADJUSTABLE IN HEIGHT AND INCLINATION
- 12 - SUPERCOMFORT SEAT
- 13 - JOYSTICK
- 14 - COAT HOOK
- 15 - DOCUMENT CARRIER



TECHNICAL DATA: SP HST

THE 32 SERIES



	4400	5008
Chassis	ACTIO™ – Full chassis with oscillation • Articulated • Hydrostatic transmission • 4 equal wheel drive	
Engine Type	Direct-injection diesel - Emissions regulations: Stage 3A	
N° Cylinders	3	4
Displacement (CC)	1642	2190
Power kW/HP (97/68/CE)	28/38	33,7/46
Maximum engine revs	3000	2700
Torque max (Nm/revs)	113/1200	14,2/1620
Cooling	Water	Water
Tank capacity (litres)	30	30
Transmission	Hydrostatic – Mechanical selector with 3 speed range: low/ normal/high – Stepless speed variator in both forward and reverse gears from 0 to 6 Km/h in the “low” range, from 0 to 12 Km/h in the “normal” range, from 0 to 30 Km/h in the “high” range with a “Speed-fix” selector for maintaining pre-set speeds	
PTO	Front independent PTO with 2 speeds 540 and 1000 rpm	
Hydraulic Lift	Double acting, with two-speed lift and descent, controlled by joystick - Capacity (Kg): 1100	
Operating Pressure (bar)	150	
Steering	Hydraulic power steering with 2 cylinders and Load Sensing system	
Brakes	Service and parking brakes	
Tyres	*240/70 R15 **6.50x16 ***29x12.50-15 Terra / Green / Xtra-Traction	
Weight (Kg)	1220	1470

Dimensions

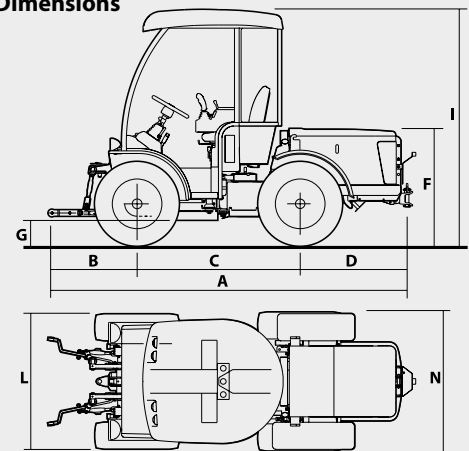

SP 4400 HST

	A	B	C	D	F	G	I	L	N
*	2980	718	1382	880	961	182	1964	1149	1180
**	2980	718	1382	880	990	211	1993	1116	1127
***	2980	718	1382	880	976	200	1982	1307	1321

SP 5008 HST

	A	B	C	D	F	G	I	L	N
*	3075	718	1382	975	961	182	1964	1149	1180
**	3075	718	1382	975	990	211	1993	1116	1127
***	3075	718	1382	975	976	200	1982	1307	1321

Standard features

Closed steel cab mounted on Silent-block, air conditioning with recirculation system, glass side doors, rear opening windows, system for the partial opening of the doors, green tinted rear windows, front windscreen wiper with 800 mm blade, 2 rear working lights, 2 rear view mirrors, 12V outlet, coat hook, glove compartments • Electrohydraulic inverter under the steering wheel • Pneumatically sprung comfort seat with head and armrests, safety belts, height adjustment, reclining back with lumbar adjustment • Front and rear differential lock • Tipping tray with sides, cm 95x90x20 • Disengaging drive wheels on front axle • Hydraulic system controlled by joystick, consisting of: 2 front double acting distributors with floating position, 1 rear replicated double acting distributor with floating position, 1 front oil reflow and 1 rear oil reflow (total 8 quick couplings) • Front/rear towing device • Horn, lighting equipment, electric power socket and plug, stop lights and turn signals • Digital multifunctional dashboard (tachometer/revolution counter, speed, fuel level, water temperature gauge) • Steering wheel adjustable in height and inclination • Safety starting switch on inverter, PTO and seat

Optional extras

Hydraulic power lift engine side controlled by joystick • “Grammer” seat with pneumatic suspension • Hydraulic system consisting of: 2 front double acting distributors with floating position, 1 rear independent double acting distributor with floating position, 1 front oil reflow and 1 rear oil reflow (total 8 quick couplings) • Pair of front wheel ballasts • RT 1500 HDS – Front mounted rotating mower cm 150 with turbine • GRASS COLLECTOR GC1000 – Collector hopper with hydraulic discharge, load capacity lt 1000, discharge height cm 210

The description and illustrations in this brochure are provided simply for information purposes; they are not binding and may be varied at any time without notice.

ANTONIO CARRARO SPA
Via Caltana, 24
35011 Campodarsego Padova ITALY
info@antoniocarraro.it
antoniocarraro.com
COD. 4 7318 134 - 06/2016